

---

## PID + Fuzzy Logic Process Controller C22/C62/C82/C83/C72/C42/R22

### User Manual

---





## Revision History

Version	Description	Date
UM0C621H	<ul style="list-style-type: none"> <li>❖ Updated for firmware C62/C22/R22 V15 &amp; C42/C82/C83/C72 V08</li> <li>❖ User Security information updated</li> <li>❖ RS485 Signed Integer Data type added</li> <li>❖ Communication chapter added with mode and command details.</li> </ul>	January, 2021
UM0C621I	<ul style="list-style-type: none"> <li>❖ RTD range specification updated</li> <li>❖ Terminal connection images updated in chapter 2</li> </ul>	April, 2021
UM0C621J	<ul style="list-style-type: none"> <li>❖ EI note added</li> <li>❖ Operation Mode Information added</li> </ul>	February, 2022
UM0C621K	<ul style="list-style-type: none"> <li>❖ PRON function updated, compatible with FW Ver16</li> <li>❖ OFS1 adds S16b function</li> <li>❖ Dwell Timer description change in chapter 3.</li> <li>❖ E1FN~E3FN parameter 20 is altered to d.R.SP function. Remote Setpoint setting description updated in Chapter 3.20.1</li> <li>❖ Maximum Screw torque in Chapter 2.3</li> <li>❖ AXFT default value changes to 0.</li> <li>❖ Approval Standards of Safety</li> </ul>	Sep,2023

## Warning Symbol

This document contains notices that you should observe to ensure your safety, as well as to protect the product and connected equipment. These notices are highlighted in the manual by a warning triangle and are marked as follows.

 The danger symbol indicates that death or severe personal injury may result if proper precautions are not taken. Do not proceed beyond a Warning symbol until the indicated conditions are fully understood and met.

## Preface

Original equipment manufacturer reserves the right to change information available in this document without notice. The manufacturer is not liable for any damages incurred to equipment/personal during installation or use of equipment as explained in this document. User must acquire sufficient knowledge & skills before using equipment in the application and follow all the local standards & regulations to meet safety requirements.

## Copyright

The documentation and the software included with this product are copyrighted 2016 by Brainchild Electronic Co. Ltd. All rights are reserved. Brainchild Electronic Co., Ltd. reserves the right to make improvements in the products described in this manual at any time without notice.

No part of this manual may be reproduced/copied/translated or transmitted in any form or by any means without the prior written permission of Brainchild Electronic Co., Ltd. The information we supply is believed to be accurate and reliable as of this printing. However, we assume no responsibility for its use.

## NOTE

It is strongly recommended that a process should incorporate a Limit Control like a Brainchild L91 which will shut down the equipment at a preset process condition to avoid possible damage to products or systems.

## Contact Information

<b>Head Office &amp; Factory</b> Brainchild Electronic Co. Ltd.	<b>China Sales Office</b> Brainchild Electronic (Kunshan) Co. Ltd.
--	---

209 Chongyang Road, Nangang Dist., Taipei 11573, Taiwan Tel: +886-2-2786-1299 Fax: +886-2-2786-1395 Website: www.brainchildtw.com; Email: sales@brainchild.com.tw; service@brainchild.com.tw	Room 405, Building #6, Huamin Gentlefolk Garden No. 13, Qianjin Central Road, Kunshan City, Jiangsu 215300, China Tel: +86-512-5511-6133 Fax: +86-512-5511-6113 Website: www.brainchild.com.cn; Email: sales@brainchild.com.cn ; service@brainchild.com.cn
--	---

## TABLE OF CONTENTS

<b>1 INTRODUCTION.....</b>	<b>11</b>
<b>1.1 Introduction.....</b>	<b>11</b>
<b>1.2 Features.....</b>	<b>11</b>
<b>1.3 Specifications.....</b>	<b>15</b>
<b>1.4 Ordering Code.....</b>	<b>19</b>
1.4.1 C22 Ordering Code.....	19
1.4.2 C62 Ordering Code.....	20
1.4.3 C82, C83, C42 Ordering Code.....	21
1.4.4 C72 Ordering Code.....	22
1.4.5 R22 Ordering Code.....	23
1.4.6 Accessories.....	23
1.4.7 Related Products.....	24
<b>1.5 Programming Port.....</b>	<b>24</b>
<b>1.6 Keys and Displays.....</b>	<b>24</b>
<b>1.7 Menu Flowchart.....</b>	<b>29</b>
1.7.1 User Menu .....	29
1.7.2 Setup Menu.....	30
1.7.2.1 Basic Menu (bASE) .....	30
1.7.2.2 Output Menu (oUT).....	31
1.7.2.3 Event Input Menu (EI) .....	32
1.7.2.4 Alarm Menu (ALRM).....	32
1.7.2.5 User Select Menu (SEL) .....	33
1.7.2.6 Communication Menu (CoMM) .....	34
1.7.2.7 Current Transformer Input Menu (Ct).....	34
1.7.2.8 Profile Menu (PRoF) .....	34
1.7.3 Manual Mode Menu .....	35
1.7.4 Auto-Tuning Mode.....	36
1.7.5 Calibration Mode .....	36
<b>1.8 Parameter Availability Table .....</b>	<b>36</b>
<b>1.9 Parameters Description.....</b>	<b>43</b>
 <b>2 INSTALLATION AND WIRING.....</b>	 <b>63</b>
<b>2.1 Unpacking .....</b>	<b>63</b>
<b>2.2 Mounting .....</b>	<b>63</b>
2.2.1 C22 Dimension .....	63
2.2.2 C62 Dimension .....	66
2.2.3 C82 Dimension .....	68
2.2.4 C83 Dimension .....	69
2.2.5 C72 Dimension .....	70
2.2.6 C42 Dimension .....	72

2.2.7 R22 Dimension .....	74
2.2.8 CT98-1 Dimension .....	75
<b>2.3 Wiring .....</b>	<b>75</b>
2.3.1 C22 Terminal Connection .....	76
2.3.2 C62 Terminal Connection .....	77
2.3.3 C82 & C42 Terminal Connection .....	77
2.3.4 C83 Terminal Connection .....	78
2.3.5 C72 Terminal Connection .....	79
2.3.6 R22 Terminal Connection .....	81
<b>2.4 Power Wiring .....</b>	<b>82</b>
<b>2.5 Sensor Installation .....</b>	<b>82</b>
<b>2.6 Sensor Input Wiring .....</b>	<b>83</b>
<b>2.7 Control Output Wiring .....</b>	<b>83</b>
2.7.1 Output 1 .....	83
2.7.2 Output 2 .....	85
<b>2.8 Alarm Wiring .....</b>	<b>87</b>
2.8.1 Alarm 1 .....	87
2.8.2 Alarm 2 .....	87
2.8.3 Alarm 3 .....	87
2.8.4 Alarm 4 .....	88
<b>2.9 Event Input Wiring .....</b>	<b>88</b>
<b>2.10 CT Input Wiring .....</b>	<b>89</b>
<b>2.11 RS-485 Data Communication .....</b>	<b>89</b>
<b>2.12 Retransmission Wiring .....</b>	<b>89</b>
<b>2.13 Remote Setpoint Wiring .....</b>	<b>90</b>
<b>3 PROGRAMMING .....</b>	<b>91</b>
<b>3.1 User Security .....</b>	<b>91</b>
<b>3.2 Signal Input .....</b>	<b>91</b>
<b>3.3 Control Output .....</b>	<b>92</b>
3.3.1 Heat Only ON-OFF Control .....	92
3.3.2 Heat only P or PD Control .....	92
3.3.3 Heat only PID Control .....	93
3.3.4 Cool only Control .....	93
3.3.5 Other Setup Required .....	93
3.3.6 CPB Programming .....	93
3.3.7 DB Programming .....	93
3.3.8 Output 2 ON-OFF Control (Alarm function) .....	94
<b>3.4 Soft-Start .....</b>	<b>94</b>
<b>3.5 Alarm .....</b>	<b>94</b>
3.5.1 Alarm Types .....	95
3.5.2 Alarm Modes .....	104
3.5.2.1 Normal Alarm: ALMD = NORM .....	104
3.5.2.2 Latching Alarm: ALMD = LTCH .....	104
3.5.2.3 Holding Alarm: ALMD = HOLD .....	104
3.5.2.4 Latching / Holding Alarm: ALMD = LT. HO .....	104
3.5.2.5 Setpoint Holding Alarm: ALMD = SP. HO .....	104
3.5.2.6 Latching None Reset Alarm =Lt.N.R .....	104
3.5.3 Alarm Delay .....	106
3.5.4 Alarm Failure Transfer .....	107
<b>3.6 User Select Menu Configuration .....</b>	<b>107</b>

<b>3.7 Ramp</b> .....	<b>108</b>
3.7.1 Example of Ramp without Dwell Timer .....	108
<b>3.8 Dwell Timer</b> .....	<b>109</b>
<b>3.9 User Calibration</b> .....	<b>109</b>
<b>3.10 Digital Filter</b> .....	<b>110</b>
<b>3.11 Failure Transfer</b> .....	<b>110</b>
3.11.1 Output 1 Failure Transfer .....	111
3.11.2 Output 2 Failure Transfer .....	111
3.11.3 Alarm Failure Transfer .....	111
<b>3.12 Auto-Tuning</b> .....	<b>111</b>
3.12.1 Auto-Tuning Operation Steps .....	111
3.12.2 Auto-Tuning Error .....	112
3.12.3 Solution for Auto-Tuning Error .....	112
<b>3.13 Manual Tuning</b> .....	<b>112</b>
<b>3.14 Manual Control</b> .....	<b>112</b>
3.14.1 Exit Manual Control .....	113
<b>3.15 Default Setting</b> .....	<b>113</b>
3.15.1 Factory Default Setting .....	113
3.15.2 User Default Setting .....	113
3.15.2.1 Store User Default Setting.....	113
3.15.2.2 Load User Default Setting .....	114
<b>3.16 Data Communication</b> .....	<b>114</b>
3.16.1 RS-485 Setup .....	114
<b>3.17 Retransmission</b> .....	<b>114</b>
<b>3.18 Heater Current Monitoring</b> .....	<b>114</b>
<b>3.19 Operation Mode</b> .....	<b>115</b>
<b>3.20 Event Input</b> .....	<b>115</b>
3.20.1 Event Input Functions .....	116
<b>3.21 Remote Setpoint</b> .....	<b>117</b>
<b>3.22 Ramp and Soak Program</b> .....	<b>117</b>
3.22.1 PROF.....	117
3.22.2 RUN .....	117
3.22.2.1 StAR .....	118
3.22.2.2 CoNt .....	118
3.22.2.3 PV .....	118
3.22.2.4 Hold .....	118
3.22.2.5 StoP .....	118
3.22.3 RMPU .....	118
3.22.4 STAR .....	118
3.22.5 END .....	118
3.22.5.1 SP1.....	118
3.22.6 PFR .....	118
3.22.6.1 CONT .....	118
3.22.6.2 PV .....	119
3.22.6.3 SP1.....	120
3.22.7 Holdback .....	120
3.22.8 CYC .....	120
3.22.9 Running, Holding and Stopping a Profile .....	120
3.22.10 Viewing and Modifying the Profile Progress .....	120
3.22.11 Configuring the Profile .....	120
3.22.11.1 Profile Segment Parameters .....	121
3.22.11.1.1 Target Set point .....	121

3.22.11.1.2 Ramp Time.....	121
3.22.11.1.3 Soak Time .....	121
<b>3.23 Transmitter Power Supply.....</b>	<b>121</b>
<b>4 APPLICATIONS.....</b>	<b>122</b>
<b>4.1 Heat Only Control with Dwell Timer.....</b>	<b>122</b>
<b>4.2 Cool Only Control.....</b>	<b>123</b>
<b>4.3 Heat and Cool Control.....</b>	<b>123</b>
<b>4.4 Ramp &amp; Dwell .....</b>	<b>124</b>
4.4.1 Temperature Cycling Chamber .....	124
4.4.2 Programmable Bread Baking Oven .....	125
<b>4.5 Remote Setpoint .....</b>	<b>126</b>
<b>4.6 RS 485 Communication in Controller.....</b>	<b>127</b>
<b>4.7 Retransmission Application.....</b>	<b>128</b>
<b>4.8 Ramp &amp; Soak Profile in Heat Treatment Chamber.....</b>	<b>129</b>
<b>5 CALIBRATION.....</b>	<b>132</b>
<b>5.1 Equipment Required Before Calibration.....</b>	<b>132</b>
5.1.1 Manual Calibration Procedure .....	132
5.1.1.1 Calibrate Zero of A to D Converter.....	132
5.1.1.2 Calibrate Gain of A to D Converter.....	132
5.1.1.3 Calibrate Offset of Cold Junction Compensation .....	133
5.1.1.4 Calibrate Gain of Cold Junction Compensation.....	133
5.1.1.5 Calibrate RTD Input .....	133
5.1.1.6 Calibrate Linear Input.....	134
5.1.1.7 Calibrate Remote Setpoint Input .....	134
<b>6 COMMUNICATION.....</b>	<b>136</b>
<b>6.1 Functions Supported .....</b>	<b>136</b>
6.1.1 Function Code 03: Read Holding Registers .....	136
6.1.2 Function Code 06: Pre-set Single Register .....	137
6.1.3 Function Code 16: Pre-set Multiple Register .....	137
<b>6.2 Exception Responses.....</b>	<b>138</b>
<b>6.3 Parameter Mapping .....</b>	<b>138</b>
<b>6.4 Error Code .....</b>	<b>138</b>
<b>6.5 Mode .....</b>	<b>139</b>
<b>6.6 Command Mode .....</b>	<b>140</b>
<b>6.7 PROG Code.....</b>	<b>140</b>
<b>6.8 Scaling.....</b>	<b>141</b>
<b>6.9 Data Conversion.....</b>	<b>141</b>
<b>6.10 Communication Examples.....</b>	<b>141</b>
6.10.1 Read PV, SV, MV1 and MV2 .....	141
6.10.2 Perform Reset Function (same effect as pressing R key) .....	141
6.10.3 Enter Auto-Tuning Mode .....	142
6.10.4 Enter Manual Control Mode .....	142
6.10.5 Read All Parameters.....	142
6.10.6 Modify Calibration Co-efficient.....	142
6.10.7 Calibrate ADLO .....	142

## TABLE OF TABLES

CONTROLLER MODELS .....	11
PARAMETER AVAILABILITY .....	43
ENVIRONMENTAL SPECIFICATION.....	63
USER ACCESS RIGHTS .....	91
CONTROL MODE .....	92
PID PARAMETER ADJUSTMENT GUIDE .....	112
FUNCTION CODE 03 .....	136
FUNCTION CODE 06 .....	137
FUNCTION CODE 16 .....	137
EXCEPTION CODE .....	138
ERROR CODE .....	139
OPERATION MODE .....	139
COMMAND MODE .....	140
PROGRAM CODE .....	140
SCALING FOR PV, SV, SP1, INLO,INHI,SP1L,SP1H,RELO,REHI .....	141
SCALING FOR PB, O1HY, RR, O2HY, ALHY .....	141

## TABLE OF FIGURES

FUZZY PID CONTROL .....	12
PROGRAMMING PORT .....	13
PROGRAMMING PORT .....	24
PROGRAMMING PORT CONNECTION WITH PROGRAMMING PORT ADAPTOR.....	24
C22 FRONT PANEL KEYS AND DISPLAY .....	25
C62 FRONT PANEL KEYS AND DISPLAY .....	26
C82 FRONT PANEL KEYS AND DISPLAY .....	26
C83 FRONT PANEL KEYS AND DISPLAY .....	27
C72 FRONT PANELS KEYS AND DISPLAY .....	27
C42 FRONT PANEL KEYS AND DISPLAY .....	28
R22 FRONT PANEL KEYS AND DISPLAY .....	28
HOW CHARACTERS ARE DISPLAYED ON THE LCD SCREEN .....	29
C22 DIMENSIONS WITH CLAMP .....	64
C22 DIMENSION WITHOUT CLAMP .....	65
C62 DIMENSION WITH CLAMP .....	66
C62 DIMENSION WITHOUT CLAMP .....	67
C82 DIMENSION WITH CLAMP .....	68
C82 DIMENSION WITHOUT CLAMPS.....	69
C83 DIMENSION WITH CLAMPS .....	69
C83 DIMENSION WITHOUT CLAMP .....	70
C72 DIMENSION WITH CLAMP .....	70
C72 DIMENSION WITHOUT CLAMP .....	71
C42 DIMENSION WITH CLAMPS .....	72
C42 DIMENSION WITHOUT CLAMP .....	73
R22 DIMENSION .....	74
CT98-1 DIMENSION.....	75
CT98-1 APPEARANCE.....	75
LEAD TERMINAL FOR ALL MODELS EXCEPT C22.....	76
LEAD TERMINAL FOR C22 .....	76
C22 REAR TERMINAL CONNECTION .....	76
C62 REAR TERMINAL CONNECTION .....	77
C82 & C42 REAR TERMINAL CONNECTION .....	78
C83 REAR TERMINAL CONNECTION .....	79
C72 REAR TERMINAL CONNECTION .....	80
R22 TERMINAL CONNECTION .....	81
POWER WIRING .....	82
SENSOR INPUT WIRING .....	83
OUTPUT 1 RELAY TO DRIVE LOAD.....	83
OUTPUT 1 RELAY TO DRIVE CONTACTOR .....	84
OUTPUT1 PULSED VOLTAGE TO DRIVE SSR.....	84
OUTPUT 1 LINEAR CURRENT CONTROL .....	85
OUTPUT 1 LINEAR VOLTAGE CONTROL.....	85



OUTPUT 2 RELAY TO DRIVE LOAD .....	85
OUTPUT 2 RELAY TO DRIVE CONTACTOR .....	86
OUTPUT 2 PULSED VOLTAGE TO DRIVE SSR .....	86
OUTPUT 2 LINEAR CURRENT CONTROL .....	86
OUTPUT 2 LINEAR VOLTAGE CONTROL .....	87
ALARM 1 OUTPUT TO DRIVE LOAD .....	87
ALARM 2 OUTPUT TO DRIVE LOAD .....	87
ALARM 3 OUTPUT TO DRIVE LOAD .....	87
ALARM 4 OUTPUT TO DRIVE LOAD .....	88
EVENT INPUT WIRING .....	88
CT INPUT WIRING FOR SINGLE PHASE HEATER .....	89
RS-485 WIRING .....	89
RETRANSMISSION WIRING .....	90
REMOTE SETPOINT .....	90
CONVERSION CURVE FOR LINEAR TYPE PROCESS SIGNAL .....	91
HEAT ONLY ON-OFF CONTROL .....	92
SOFT START FUNCTION .....	94
DWELL TIMER (DTMR) .....	96
DEVIATION HIGH ALARM (DE.HI) .....	97
DEVIATION LOW ALARM (DE.LO) .....	97
DEVIATION OUT OF BAND ALARM (DB.HI) .....	98
DEVIATION IN-BAND ALARM (DB.LO) .....	99
PROCESS VALUE HIGH (PV.HI) .....	100
PROCESS VALUE LOW (PV.LO) .....	100
HEATER BREAK(H.BK) .....	101
HEATER SHORT (H.ST) .....	101
EVENT INPUT CONTROLLED OUTPUT (E1.C.O OR E2.C.O.) .....	102
RANGE HIGH (RG.HI) .....	102
RANGE LOW (RG.LO) .....	103
RANGE HIGH LOW (RG.H.L) .....	103
PROCESS VALUE HIGH- NORMAL ALARM .....	105
PROCESS VALUE HIGH- LATCHING ALARM .....	105
PROCESS VALUE HIGH- HOLDING ALARM .....	106
PROCESS VALUE HIGH- LATCHING & HOLDING ALARM .....	106
CONFIGURABLE USER MENU .....	108
RAMP FUNCTION .....	108
DWELL TIMER .....	109
TWO POINT USER CALIBRATION .....	110
FILTER CHARACTERISTICS .....	110
EFFECTS OF PID ADJUSTMENT .....	113
OPERATION MODE .....	115
POWER FAILURE RECOVERY FROM THE PROFILE AT DWELL SEGMENT .....	119
POWER FAILURE RECOVERY FROM THE PROFILE AT RAMP SEGMENT .....	119
POWER FAILURE RECOVERY FROM PV AT DWELL SEGMENT .....	119
POWER FAILURE RECOVERY FROM PV AT RAMP SEGMENT .....	120
HEAT ONLY CONTROL WITH DWELL TIMER .....	122
COOLING CONTROL .....	123
HEAT COOL CONTROL .....	123
RAMP & DWELL TEMPERATURE CYCLING CHAMBER .....	125
TEMPERATURE PROFILE FOR TEMPERATURE CYCLING CHAMBER .....	125
BREAD BAKING OVEN .....	126
TEMPERATURE PROFILE OF BAKING OVEN .....	126
REMOTE SETPOINT APPLICATION .....	127
RS-485 APPLICATION .....	128
RETRANSMISSION APPLICATION .....	129
HEAT TREATMENT CHAMBER .....	130
TEMPERATURE PROFILE OF THE HEAT TREATMENT CHAMBER .....	130
COLD JUNCTION CALIBRATION SETUP .....	133



# 1 Introduction

## 1.1 Introduction

The new generation low-cost PID microprocessor-based Fuzzy logic controller series incorporate two bright easy to read LCD Displays which indicate Process Value (PV) and Setpoint (SP). The Fuzzy Logic technology incorporated on these series controllers enables a process to reach a predetermined set point in the shortest time with a minimum of overshoot during startup (Power ON) or external load disturbances (example: an oven door being opened).

Below are the different controller models of this series.

Model No	Mounting Type	DIN Size	Dimensions L x W x D(mm)	Depth Behind Panel (mm)
C22	Panel Mount	1/32 DIN	24x48x85	76
C62	Panel Mount	1/16DIN	48x48x59	50
C82/C83	Panel Mount	1/8 DIN	48x96x59	50
C72	Panel Mount	1/7 DIN	72x72x59	50
C42	Panel Mount	1/4 DIN	96x96x59	50
R22	DIN RAIL		22.5x96x80	

### 1-1 Controller Models

These controllers are powered by an 11-26 or 90-250 VDC /VAC supply, incorporating a 2 Amp control relay output as a standard. The second output can be used as a cooling control or an alarm. Both outputs can be selected as a 5VDC or 14VDC logic output, linear current or linear voltage to drive an external device. There are 13 types of alarms and a dwell timer that can be configured for the alarm output. The controllers are fully programmable for **Linear current, Linear Voltage, PT100 and thermocouple types J, K, T, E, B, R, S, N, L, U, P, C, and D**. The input signal is digitized by using an 18-bit A to D converter. Its fast-sampling rate allows the controller to control fast processes.

## 1.2 Features

The new generation of low-cost PID controllers has a lot of unique features. The unique features are listed below.

- ❖ LCD Display
- ❖ High Accuracy 18 Bit A-D Conversion and 15 Bit D-A Conversion
- ❖ Fastest Sampling Rate of 200 msec
- ❖ Universal Input
- ❖ Fuzzy Logic +PID Technology
- ❖ Possibility of both RS-485 and analog retransmission
- ❖ 16 Segments of Ramp & Soak
- ❖ Current Transformer (CT) Inputs for heater break detection
- ❖ Up to 6 Event Inputs
- ❖ Remote Setpoint
- ❖ Auto-Tuning
- ❖ Bumpless Transfer
- ❖ Lockout Protection
- ❖ Bidirectional Menu Navigation
- ❖ Soft Start function

## LCD Display

All the controllers in this series will be equipped with high brightness LCD Display.

## Digital Communication

RS-485 Digital communication is available as an additional option. These options allow the units to be integrated with supervisory control systems and software. By using twisted pair wires, up to 247 units can be connected via an RS-485 interface to a host computer.

A Micro USB programming port is available for automatic configuration, calibration and testing without the need to access the keys on the front panel.

## Fuzzy PID Technology

By using proprietary Fuzzy modified PID technology, the control loop will minimize overshoot and undershoot in the shortest allowable time. The following diagram is a comparison of results with and without Fuzzy Logic technology.

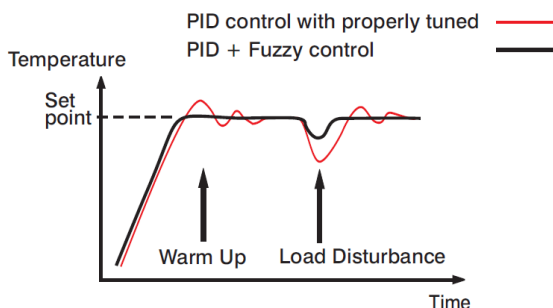

## High Accuracy

This series of controllers are manufactured using an innovative technology which contains an 18-bit A to D converter for high-resolution measurement (true 0.1°F resolution for thermocouple and PT100 sensors) and a 15-bit D to A converter for a linear current or voltage control output. The innovative technology provides improved operating performance, enhanced reliability and higher density with low cost.

## Fast Sampling Rate

The sampling rate of the input A to D converter reaches 200 msec. This fast sampling rate allows the controllers to control fast processes.

## Fuzzy Control

The function of Fuzzy control is to adjust PID parameters from time to time to make manipulation of the output more flexible and adaptive to various processes. The result is to enable a process to reach a predetermined set point in the shortest time, with a minimum of overshoot and undershoot during power-up or external load disturbances.

## Programming Port

A Micro USB programming port is available for automatic configuration, calibration and firmware upgrades without the need to access the keys on the front panel.

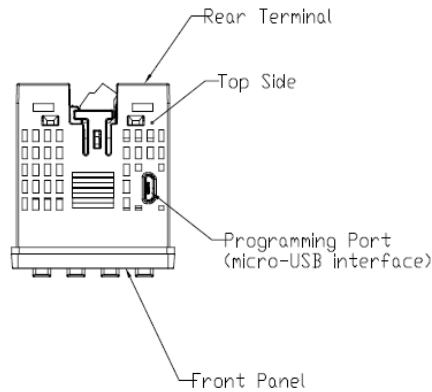

## 1-2 Programming Port

### Auto-tuning

The auto-tuning function allows the user to simplify the initial setup for a new system. A clever algorithm is provided to obtain an optimal set of control parameters for the process. It can be applied either as the process is warming up (cold start) or when the process is in a steady-state (warm start).

### Lockout Protection

According to user security requirements, different security options can be enabled by using Code and Pass parameters.

### Bumpless Transfer

The Bumpless transfer allows the controller to continue to control by using its previous output value if the input sensor breaks. Hence, the process can be well controlled temporarily as if the sensor is functioning normally.

### Soft-start Ramp

The ramping function can be performed during power up as well as any time the setpoint is changed. It can be ramped up or ramp down. The process value will reach the set point within a predetermined constant rate.

### Soft-start

The soft-start function allows limiting the power output for a programmable time (SFT) or up to a programmed threshold value (SFTH). The soft-start function will work until either one of the two reached. When soft start function is running the lower display will show the message "SFSt" alternately to the value.

### Digital Filter

A first-order low-pass filter with a programmable time constant is used to improve the stability of the process value (PV). This is particularly useful in certain applications where the process value is too unstable to be read.

### SEL Function

These controllers have the flexibility for the user to select those parameters which are most significant to them and put these parameters into the "USER" menu for quick access. There are up to 8 parameters that can be selected to allow the user to build their display sequence in the USER menu.

## **Event Input**

Event Inputs are available as an option to change certain functions and the set point. 6 Event Inputs are available in the C42, C82 and C83 models. There are two event Inputs is that available in the C62, C72 controllers, and one event input is available in the C22, R22 controllers.

## **Remote SetPoint**

A Remote Setpoint function is available to vary the setpoint by using either a linear voltage or current input. A remote setpoint is available in select models.

## **CT Input**

CT Input Options are available to detect if a heater break. There is a maximum of two CT inputs available.

## **Analog Retransmission**

Analog retransmission is available as an option.

## **Profile (Ramp/Soak) Segments**

These controllers have the option for Ramp and Soak Profiles with 16 segments. These segments can be used as 4 Profiles with each 4 segments or 2 Profiles with each 8 segments or one profile with 16 segments. This option is not available with the C22, C62 and R22 models.

## **Bidirectional Menu Navigation**

The C series controllers have bidirectional menu navigation. This will allow the user to access previous menu settings easily by using   keys.

## **PRON (New function with Firmware V20 or up)**

This parameter will only take effect every time the controller is rebooted. During power-on initialization, the controller refers to the PRON setting,

If PRON=DIS, the PRON is disable.

If PRON=RUN, the controller will output ON.

If PRON=OFF, the controller will turn off the output, that is, MV1/MV2 are both set to 0%, ALARM will also be released. (Reverse setting of Alarm will result in the opposite)

Press the up and down keys at the same time and hold for 2 seconds, the controller will switch between "All Output/Alarm On" and "All Output/Alarm Off"

### 1.3 Specifications

Specification	C22	C62	C82	C83	C72	C42	R22
Power Supply	90 to 250VAC, 47 to 63Hz, 20 to 28 VAC, 47-63Hz / 11 to 40 VDC						
Power Consumption	C22/R22: 8VA, 4W Maximum., C62: 10VA, 5W Maximum., C72/C82/C83/C42: 12VA, 6W Maximum						
Over Voltage Category	II						
<b>Signal Input</b>							
Type	Thermocouple (J, K, T, E, B, R, S, N, L, U, P, C, D), RTD(PT100(DIN), PT100(JIS)), Current(mA), Voltage (V, mV)						
Resolution	18 Bits						
Sampling Rate	5 Times / Second (200msec)						
Maximum Rating	-2VDC minimum, 12VDC maximum						
Input Characteristics	<b>Type</b>	<b>Range</b>		<b>Accuracy @ 25°C</b>		<b>Input Impedance</b>	
	J	-120°C to 1000°C (-184°F to 1832°F)		±2°C		2.2 MΩ	
	K	-200°C to 1370°C (-328°F to 2498°F)		±2°C		2.2 MΩ	
	T	-250°C to 400°C (-418°F to 752°F)		±2°C		2.2 MΩ	
	E	-100°C to 900°C (-148°F to 1652°F)		±2°C		2.2 MΩ	
	B	0°C to 1820°C (32°F to 3308°F)		±2°C (200°C to 1800°C)		2.2 MΩ	
	R	0°C to 1767.8°C (32°F to 3214°F)		±2°C		2.2 MΩ	
	S	0°C to 1767.8°C (32°F to 3214°F)		±2°C		2.2 MΩ	
	N	-250°C to 1300°C (-418°F to 2372°F)		±2°C		2.2 MΩ	
	L	-200°C to 900°C (-328°F to 1652°F)		±2°C		2.2 MΩ	
	U	-200°C to 600°C (-328°F to 1112°F)		±2°C		2.2 MΩ	
	P	0°C to 1395°C (32°F to 2543°F)		±2°C		2.2 MΩ	
	C	0°C to 2300°C (32°F to 4172°F)		±2°C		2.2 MΩ	
	D	0°C to 2300°C (32°F to 4172°F)		±2°C		2.2 MΩ	
	Land Jewel	0°C to 1880°C (32°F to 3416°F) (Not available for C22, C62 & R22)		±2°C		2.2 MΩ	
	PT100(DIN)	-210°C to 700°C (-346°F to 1292°F)		±0.4°C		1.3KΩ	
	PT100(JIS)	-200°C to 600°C (-328°F to 1112°F)		±0.4°C		1.3KΩ	
mA	-3mA to 27mA		±0.05%		2.5Ω		
VDC	-1.3VDC to 11.5VDC		±0.05%		1.5MΩ		
mV	0 to 50mV		±0.05%		2.2 MΩ		
Temperature Effect	1.5μV /°C for all inputs except mA input, 3.0μV /°C for mA						
Sensor Lead Resistance Effect	<b>Thermocouple:</b> 0.2 μV /°Ω; <b>3-wire RTD:</b> 2.6°C /Ω of Difference of Resistance of two leads <b>2-wire RTD:</b> 2.6°C /Ω of Sum of Resistance of two leads						
Burn-out Current	200nA						
CMRR	120 dB						
NMRR	55dB						
Sensor Break Detection	Sensor open for Thermocouple, RTD and mV inputs, Sensor short for RTD input, Below 1mA for 4-20mA input, Below 0.25VDC for 1 - 5VDC input, Not available for other inputs.						

Specification	C22	C62	C82	C83	C72	C42	R22
Sensor Break Response Time	Within 4 seconds for Thermocouple, RTD and mV inputs, 0.1 second for 4-20mA and 1 - 5VDC inputs.						
<b>Remote Set Point Input</b>							
Type	Linear Current, Linear Voltage						
Range	-3mA to 27mA, -1.3VDC to 11.5VDC						
Accuracy	±0.05 %						
Remote Set Point Option	Not Available	Not Available	Available	Available	Available	Available	Not Available
Input Impedance	Current: 2.5Ω, Voltage:1.5MΩ						
Resolution	18 Bits						
Sampling Rate	1.66 Times/Second						
Maximum Rating	280mA maximum for Current Input, 12VDC Maximum for Voltage Input						
Temperature Effect	±1.5μV/°C for Voltage Input, ±3.0μV/°C for Current Input						
Sensor Break Detection	Below 1mA for 4-20mA input, Below 0.25VDC for 1 - 5VDC input, Not available for other inputs.						
Sensor Break Responding Time	0.1 Second						
<b>Event Input</b>							
Number of Event Inputs	1	2	6	6	2	6	2
Logic Low	-10VDC minimum, 0.8VDC maximum.						
Logic High	2VDC minimum, 10VDC maximum						
Functions	See the availability table						
<b>CT Input</b>							
CT Type	CT98-1						
Accuracy	±5%of Full-scale Reading ±1 Digit.						
Input Impedance	294Ω						
Measurement Range	0 to 50AAC						
Output of CT	0 to 5VDC						
Sampling Rate	1 Time/Second						
<b>Output 1 /Output 2</b>							
Type	Relay, Pulsed Voltage, Linear Voltage or Linear Current						
Relay Rating	2A,240V AC,200000 Life Cycles for Resistive Load						
Pulsed Voltage	Source Voltage 5VDC, Current Limiting Resistance 66Ω						
Linear Output Resolution	15 Bits						
Linear Output Regulation	0.02% for full load change						
Linear Output Settling Time	0.1 Sec (Stable to 99.9%)						
Linear Output Ranges	0 - 22.2mA (0 - 20mA/4 - 20mA), 0 - 5.55VDC (0 - 5VDC, 1 - 5VDC),0 - 11.1VDC (0 - 10VDC)						
Isolation Breakdown Voltage	1000 VAC						
Temperature Effect	±0.01% of Span/ °C						



Specification	C22	C62	C82	C83	C72	C42	R22
Load Capacity of Linear Output	Linear Current: 500Ω max., Linear Voltage: 10KΩ min						
<b>Alarm</b>							
Relay Type	Form A						
Maximum Rating	2A,240VAC,200000 Life Cycles for Resistive Load						
Alarm Functions	Dwell Timer, Deviation Low, Deviation High, Deviation In-Band, Deviation Out of Band, Process High, Process Low, Range High, Range Low, Range High Low, Profile Hold Back, Profile end, Heater Break, Heater Short, Event Input 1 & Event Input 2 controlled alarm Output						
Alarm Mode	Latching, Hold, Normal, Latching/Hold, Setpoint Holding, Latching None Reset						
Dwell Timer	0.1 to 4553.6 Minutes						
<b>Data Communication</b>							
Interface	RS-485						
Protocol	Modbus RTU (Slave Mode)						
Address	1 to 247						
Baud Rate	2.8KBPS to 115.2KBPS						
Parity Bit	None, Even or Odd						
Stop Bit	1 or 2 Bits						
Data Length	7 or 8 Bits						
Communication Buffer	160 Bytes						
<b>Analog Retransmission</b>							
Output Signal	4-20mA, 0-20 mA,0 - 10VDC						
Resolution	15 Bits						
Accuracy	±0.05% of Span ± 0.0025% / °C						
Load Resistance	0 to 500Ω for current output, 10KΩ minimum for Voltage Output						
Output Regulation	0.01% for full load change						
Output Setting Time	0.1Second (stable to 99.9%)						
Isolation Breakdown	1000VAC min						
Integral Linearity Error	±0.005% of span						
Temperature Effect	±0.0025% of span /°C						
Saturation Low	0mA or 0VDC						
Saturation High	22.2mA or 5.55V,11.1V min						
Linear Output Ranges	0 - 22.2mA (0 - 20mA/4 - 20mA), 0 - 5.55VDC (0 - 5VDC, 1 - 5VDC),0 - 11.1VDC (0 - 10VDC)						
<b>User Interface</b>							
Keypad	4 Keys						
Display Type	4 Digit LCD Display						
No of Display	2	2	3	3	3	3	2
Upper Display Size	0.4" (10mm)	0.58" (15mm)	0.7" (17.7mm)	0.7" (17.7mm)	0.58" (15mm)	0.98" (25mm)	0.31" (8mm)
Lower Display Size	0.19" (4.8mm)	0.3" (7.8mm)	0.4" (11.2mm)	0.4" (11.2mm)	0.32" (8.3mm)	0.55" (14mm)	0.25" (6.5mm)
<b>Programming Port</b>							
Interface	Micro USB						

Specification	C22	C62	C82	C83	C72	C42	R22
PC Communication Function	Firmware upgrade						
<b>Control Mode</b>							
Output 1	Reverse (Heating) or Direct (Cooling) Action						
Output 2	PID cooling control, Cooling P band 50~300% of PB, Dead band -36.0 ~ 36.0 % of PB						
ON-OFF	0.1~50.0°C (0.1~90.0°F) hysteresis control (P band = 0)						
P or PD	0 - 100.0 % offset adjustment						
PID	Fuzzy logic modified Proportional band 0.1 ~ 500.0°C(0.1~900.0°F), Integral time 0 – 3600 Secs, Derivative Time 0 - 360.0 Secs						
Cycle Time	0.1 to 90.0 Seconds						
Manual Control	Heat (MV1) and Cool (MV2)						
Auto-Tuning	Cold Start and Warm Start						
Failure Mode	Auto transfer to manual mode while sensor break or A-D Converter damage						
Ramping Control	0 to 500.0°C (0 to 900.0°F)/Minute or 0 to 500.0°C (0 to 900.0°F)/Hour Ramp Rate						
<b>Digital Filter</b>							
Function	First Order						
Time Constant	0,0.2, 0.5, 1, 2, 5, 10, 20, 30, 60 Seconds, Programmable						
<b>Profiler</b>							
Availability	No	No	Option	Option	Option	Option	No
No of Programs	NA	NA	1Program with 16 Segments or 2Programs with each 8 Segments or 4Programs with each 4 Segments				NA
<b>Environmental and Physical Specifications</b>							
Operating Temperature	-10°C to 50°C						
Storage Temperature	-40°C to 60°C						
Humidity	0 to 90 % RH (Non-Condensing)						
Altitude	2000 Meters Maximum						
Pollution	Degree II						
Insulation Resistance	20MΩ Minimum (@500V DC)						
Dielectric Strength	2000VAC,50/60 Hz for 1 Minute						
Vibration Resistance	10 to 55 Hz, 10m/s <sup>2</sup> for 2 Hours						
Shock Resistance	200 m/s <sup>2</sup> (20g)						
Housing	Flame Retardant Polycarbonate						
Mounting	Panel	Panel	Panel	Panel	Panel	Panel	DIN-Rail
DIN Size	1/32	1/16	1/8	1/8	9/64	1/4	
Dimensions (W*H*D) (mm)	48*24*92	48*48*59	48*96*59	96*48*59	72*72*59	96*96*59	22.5*96*83
Depth Behind Panel (mm)	84	50	50	50	50	50	
Cut Out Dimensions (mm)	45*22.2	45*45	45*92	92*45	68*68	92*92	
Weight (grams)	120	160	220	220	190	290	160
<b>Approval Standards</b>							
Safety	UL 61010-1, 3rd Edition, CAN/CSA-C22.2 No. 61010-1(2012-05), 3rd Edition, ROHS, REACH						

Specification	C22	C62	C82	C83	C72	C42	R22
Protective Class	IP50 for the front panel, IP20 for rear terminals and housing. All indoor use.						
EMC	EN61326						

## 1.4 Ordering Code

### 1.4.1 C22 Ordering Code

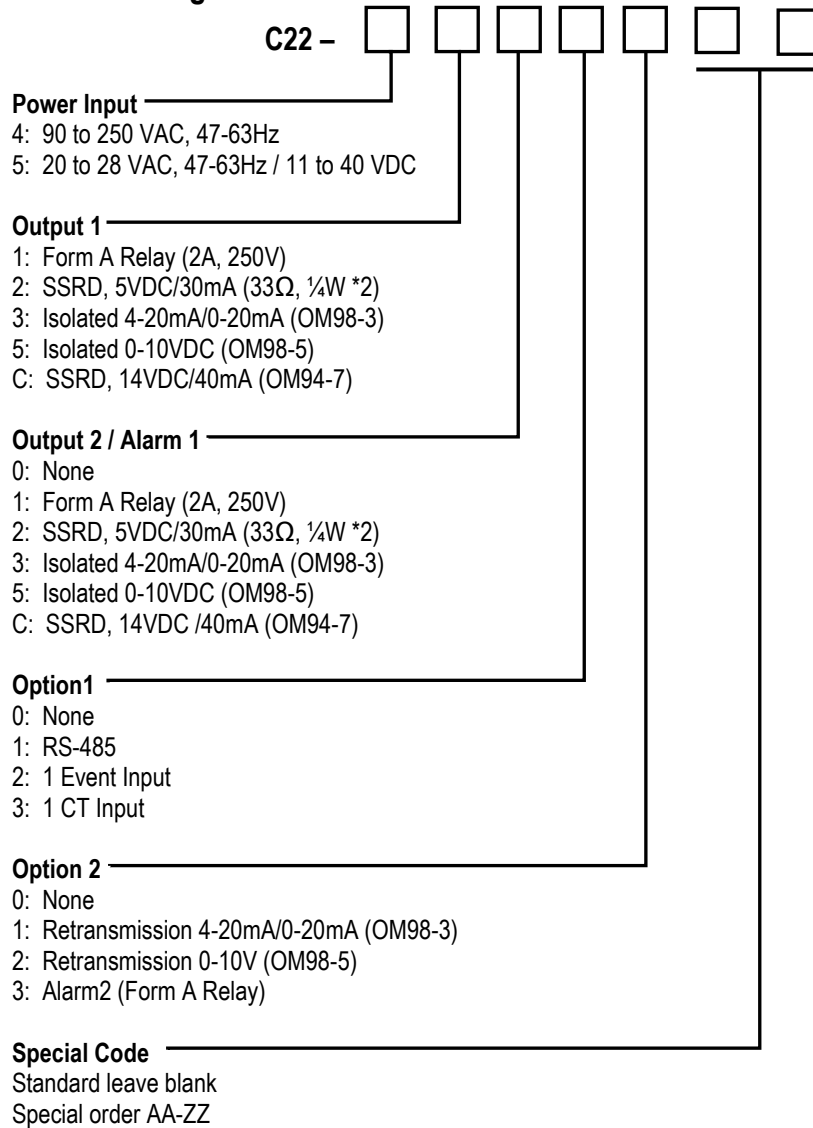

## 1.4.2 C62 Ordering Code

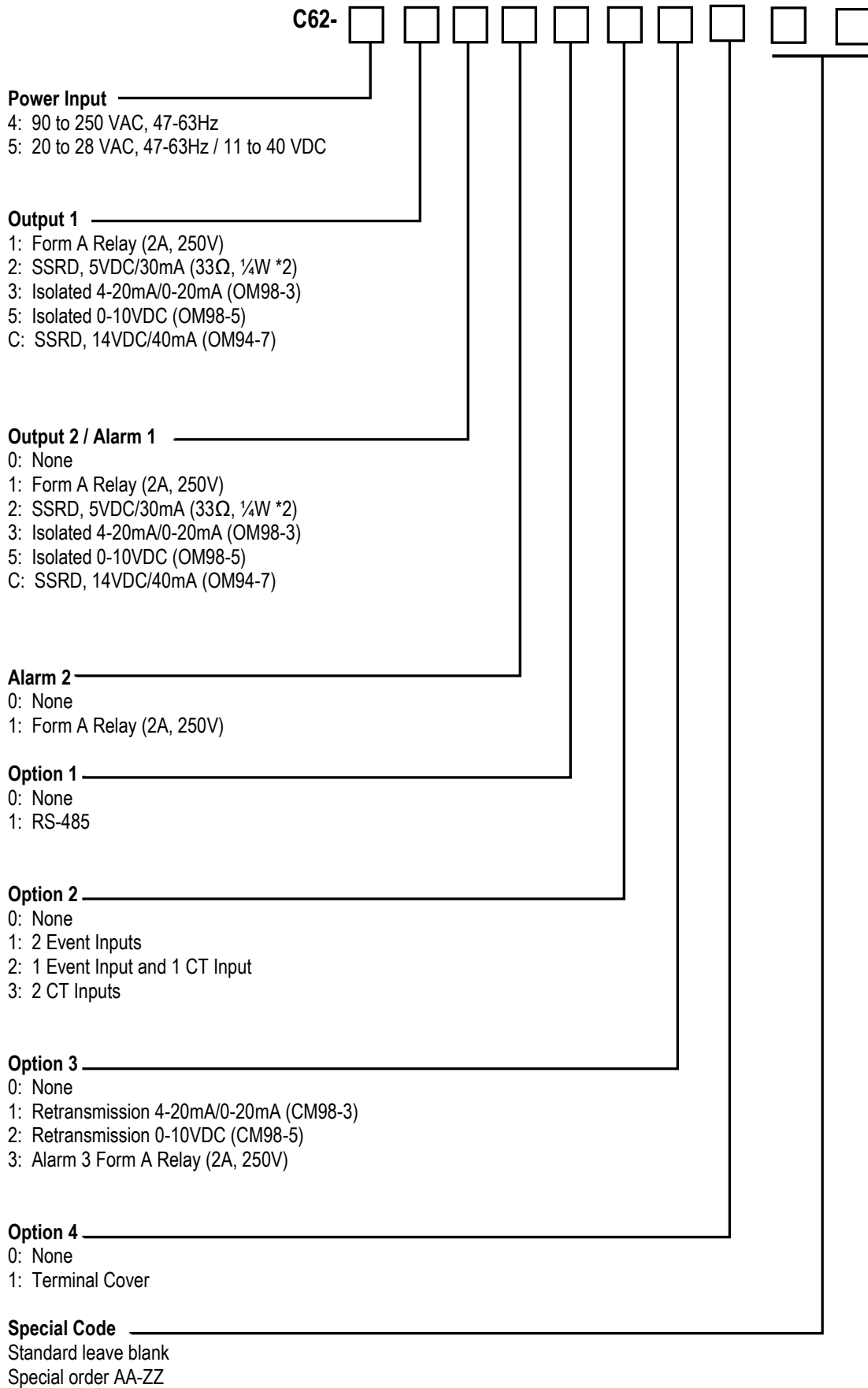

### 1.4.3 C82, C83, C42 Ordering Code

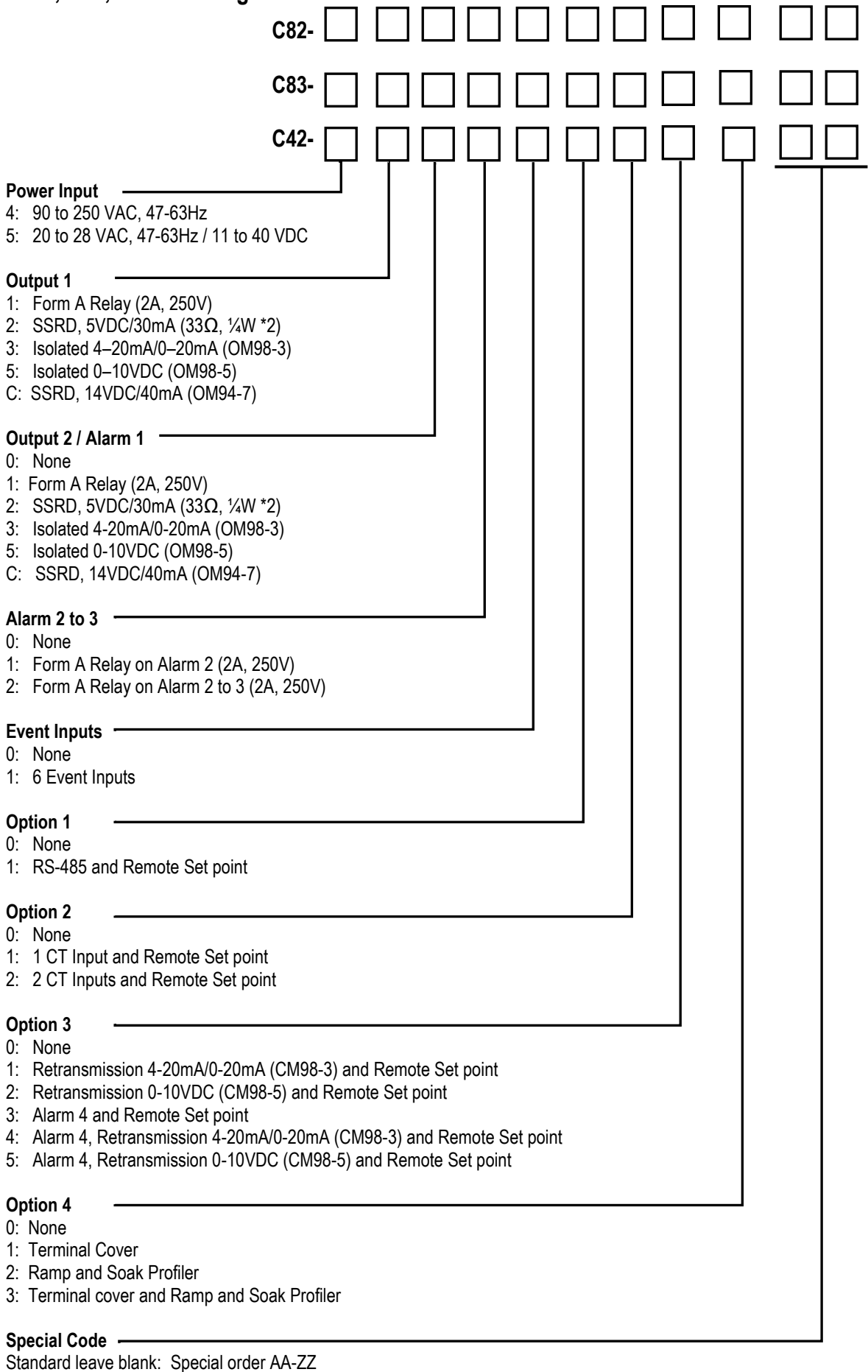

## 1.4.4 C72 Ordering Code

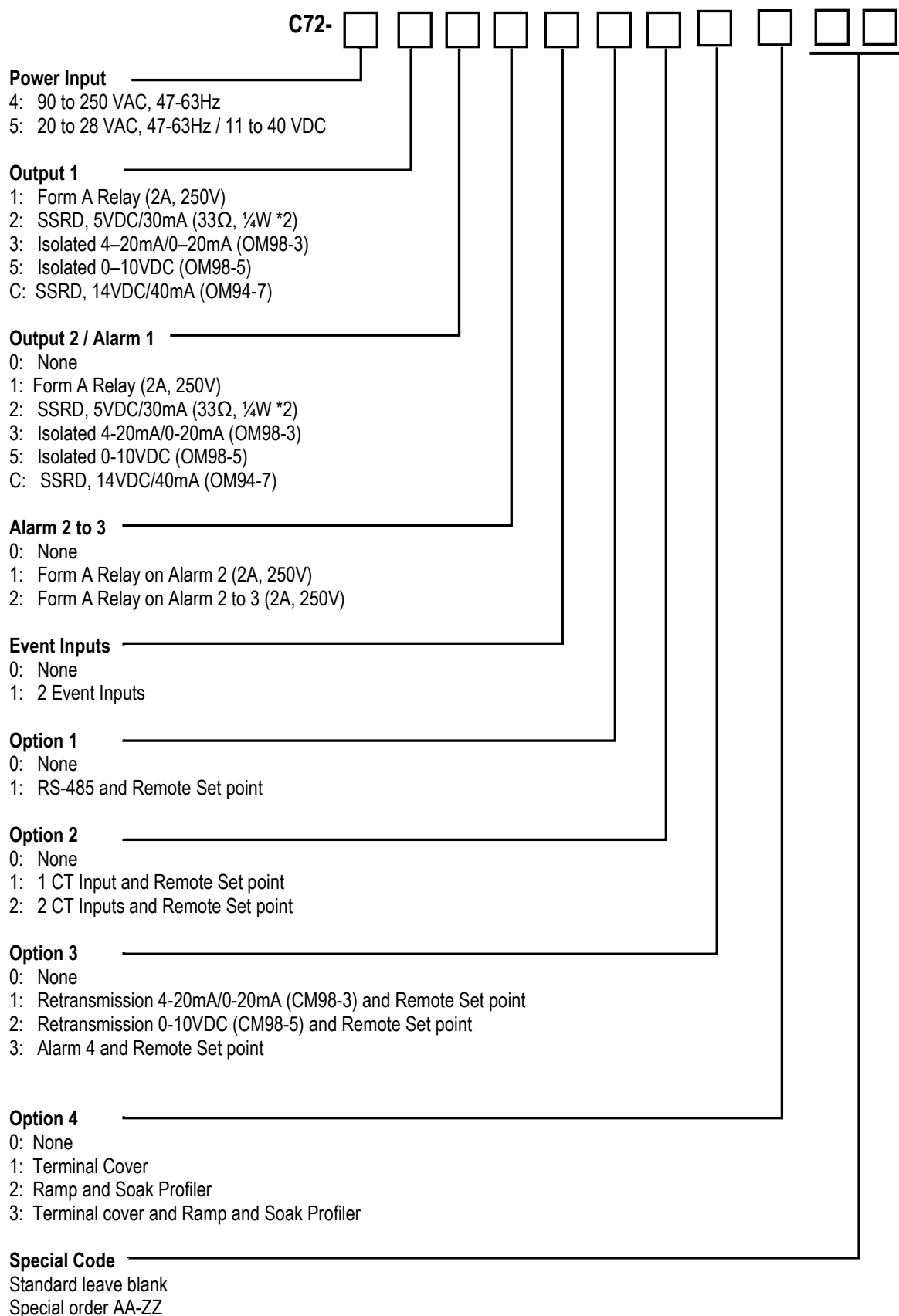

## 1.4.5 R22 Ordering Code

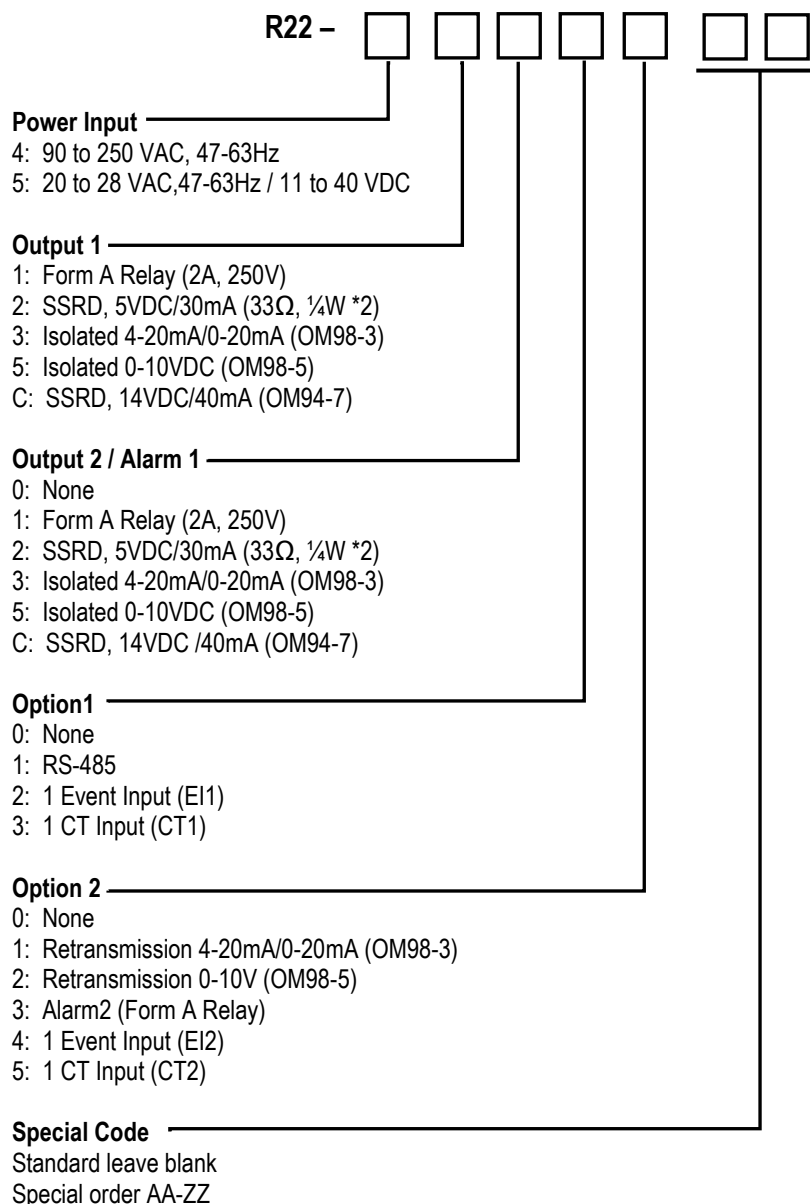

## 1.4.6 Accessories

- OM94-7 = 14VDC/40mA SSR Drive Module
- OM98-3 = Isolated 4-20mA/0-20mA Analog Output Module
- OM98-5 = Isolated 0-10VDC Analog Output Module
- CM98-3 = Isolated 4-20mA/0-20mA Retransmission Module for all models except C22 & R22
- CM98-5 = Isolated 0-10VDC Retransmission Module for all models except C22 & R22
- PA98-1 = USB Programming Adaptor
- CC98-1 = Programming Port Cable (1.5m)
- CT98-1 = Current Transformer
- DC94-1 = Isolated 20V,20mA DC Output Power Supply
- DC94-2 = Isolated 12V,40mA DC Output Power Supply
- DC94-3 = Isolated 5V,80mA DC Output Power Supply

**Note:** DC94-1, DC94-2, DC94-3 can be inserted in the output2 location on all the models for transducer power supply.

### 1.4.7 Related Products

BC-Set Pro = Configuration Software

### 1.5 Programming Port

A Micro USB Port provided on the controller can be used to connect to a PC by using a programming port cable (CC98-1) and a programming adapter (PA98-1) for firmware upgrades. The controller can also be connected to an ATE system for automatic calibration and testing using the micro-USB port. The programming port is used for off-line automatic setup and testing procedures only. Do not attempt to make any connections to this port while the controller is being used during normal operation.

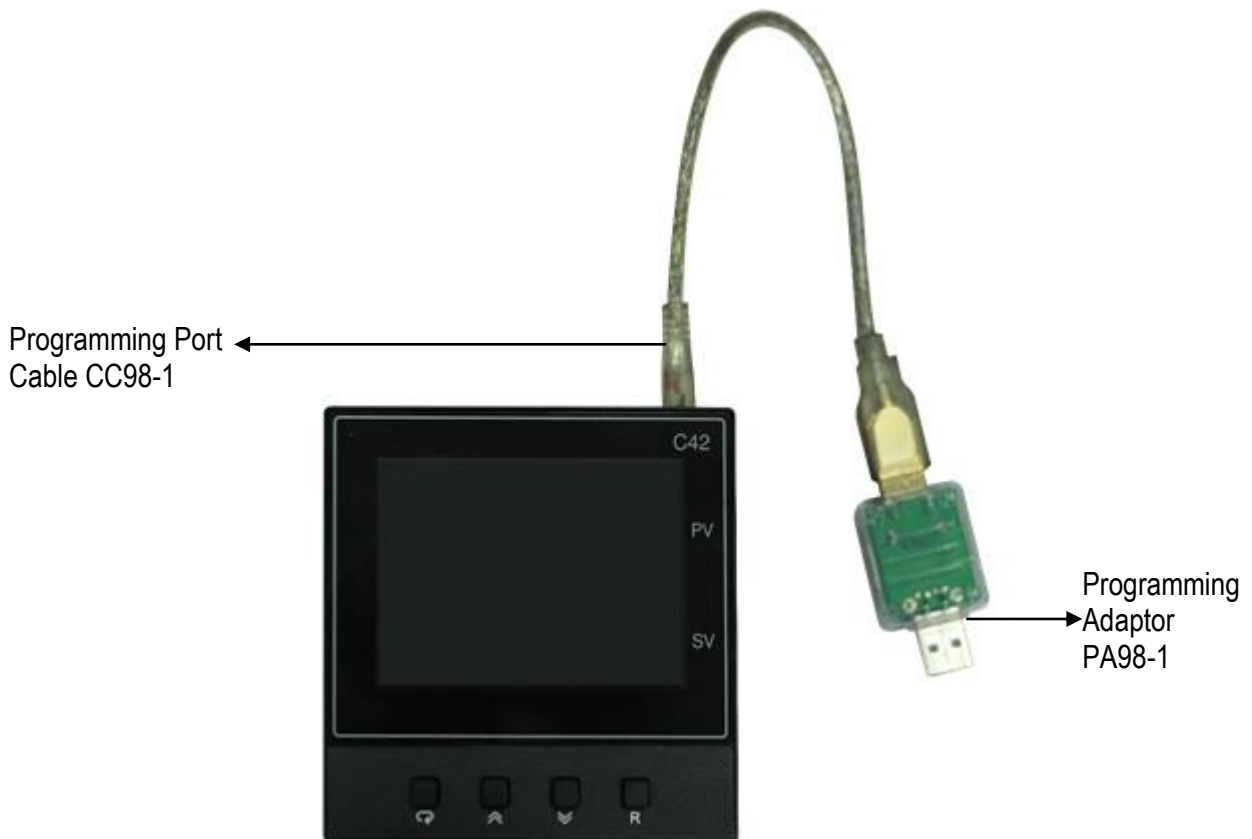
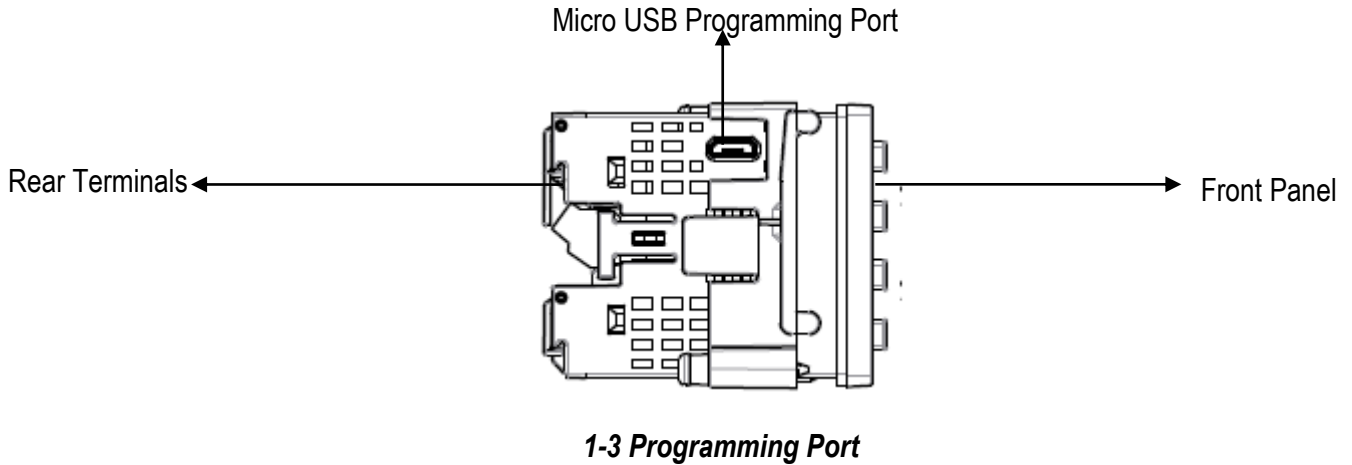

**1-4 Programming Port Connection with Programming Port Adaptor**

### 1.6 Keys and Displays

#### KEYPAD OPERATION



**SCROLL KEY:** 

This key is used to select a parameter to be viewed or adjusted.

**UP KEY:** 

This key is used to increase the value of the selected parameter.

**DOWN KEY:** 

This key is used to decrease the value of the selected parameter.





**RESET KEY:** 

This key is used to:

1. Revert the display to the home screen.
2. Reset a latching alarm once the alarm condition is removed.
3. Stop manual control mode, Auto-Tuning mode or calibration mode.
4. Clear an Auto-Tuning or communication error message.
5. Restart the dwell timer when the dwell timer has timed out.
6. Enter the manual control menu if a failure mode occurs.

**ENTER KEY:**

Press  and hold for 5 seconds or longer to:

1. Enter the setup menu. The display will show. 
2. Enter the manual control mode. The display will show. 
3. Enter the Auto-Tuning mode. The display will show. 
4. Perform  calibration of a selected parameter during the calibration procedure. The  display will show

Press and hold  for 6.2 seconds, then let go, to select manual control mode.

Press and hold  for 7.4 seconds, then let go to select Auto-Tuning mode.

Press and hold  for 8.6 seconds, then let go to select calibration mode.

During power-up, the upper display will show PROG and the lower display will show the Firmware version for 6 seconds.

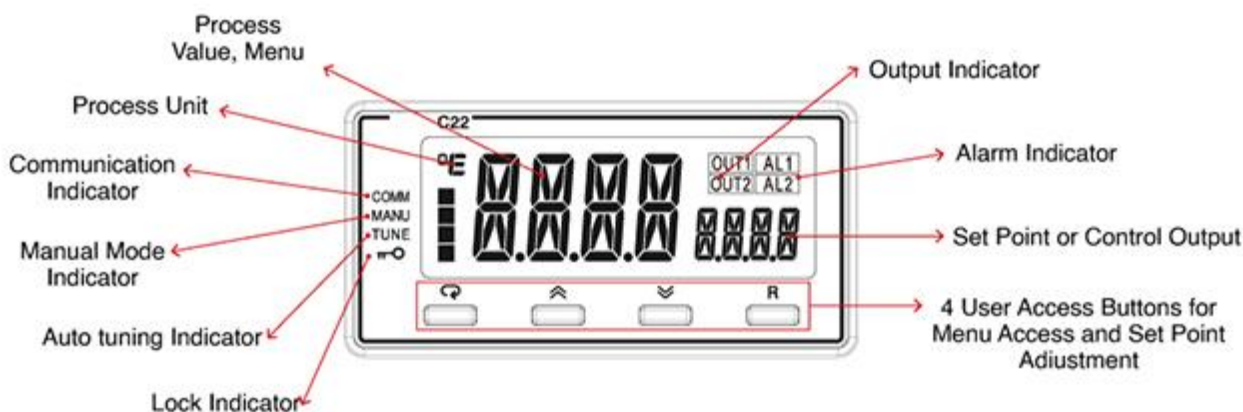

**1-5 C22 Front Panel Keys and Display**

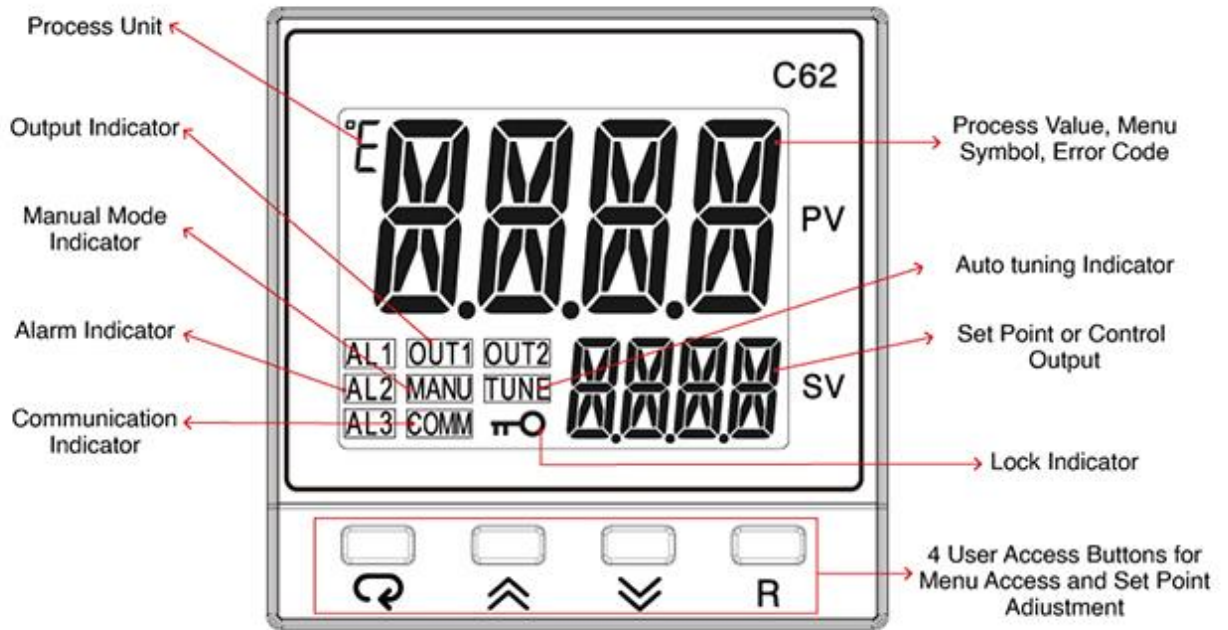

**1-6 C62 Front Panel Keys and Display**

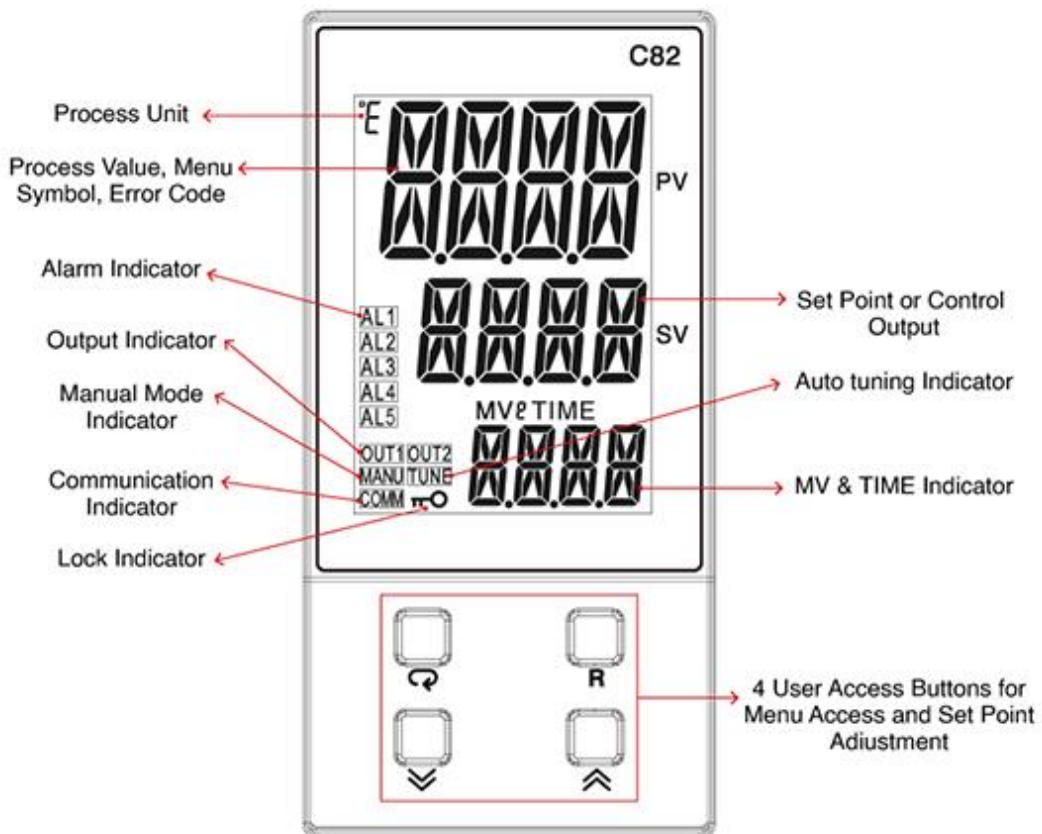

**1-7 C82 Front Panel Keys and Display**

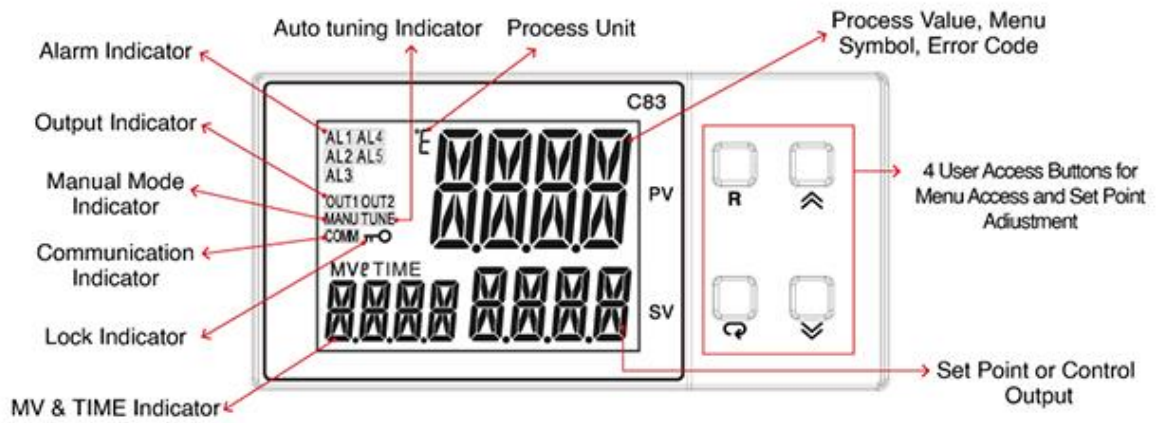

**1-8 C83 Front Panel Keys and Display**

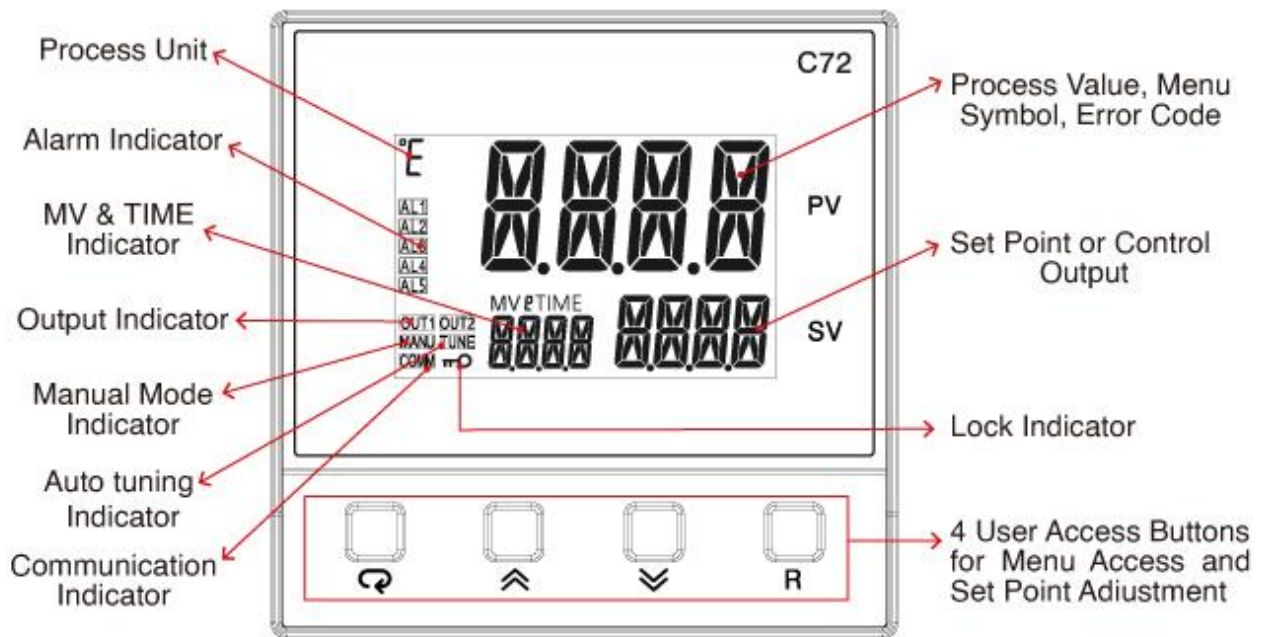

**1-9 C72 Front Panels Keys and Display**

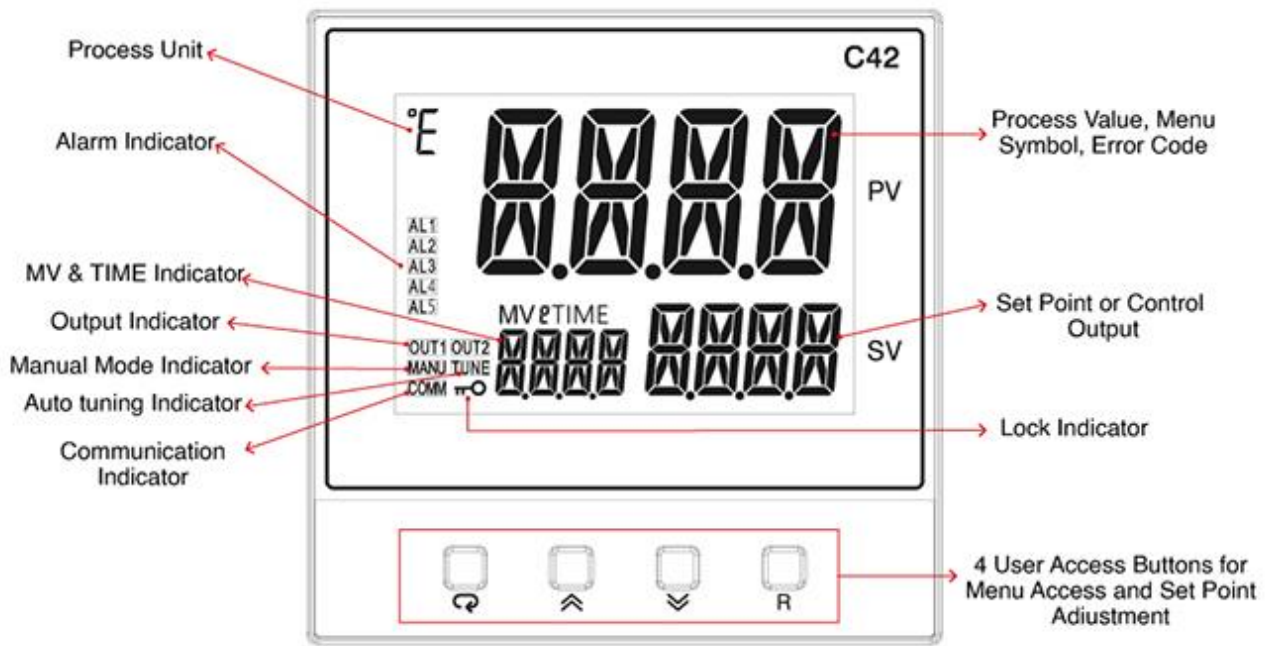

**1-10 C42 Front Panel Keys and Display**

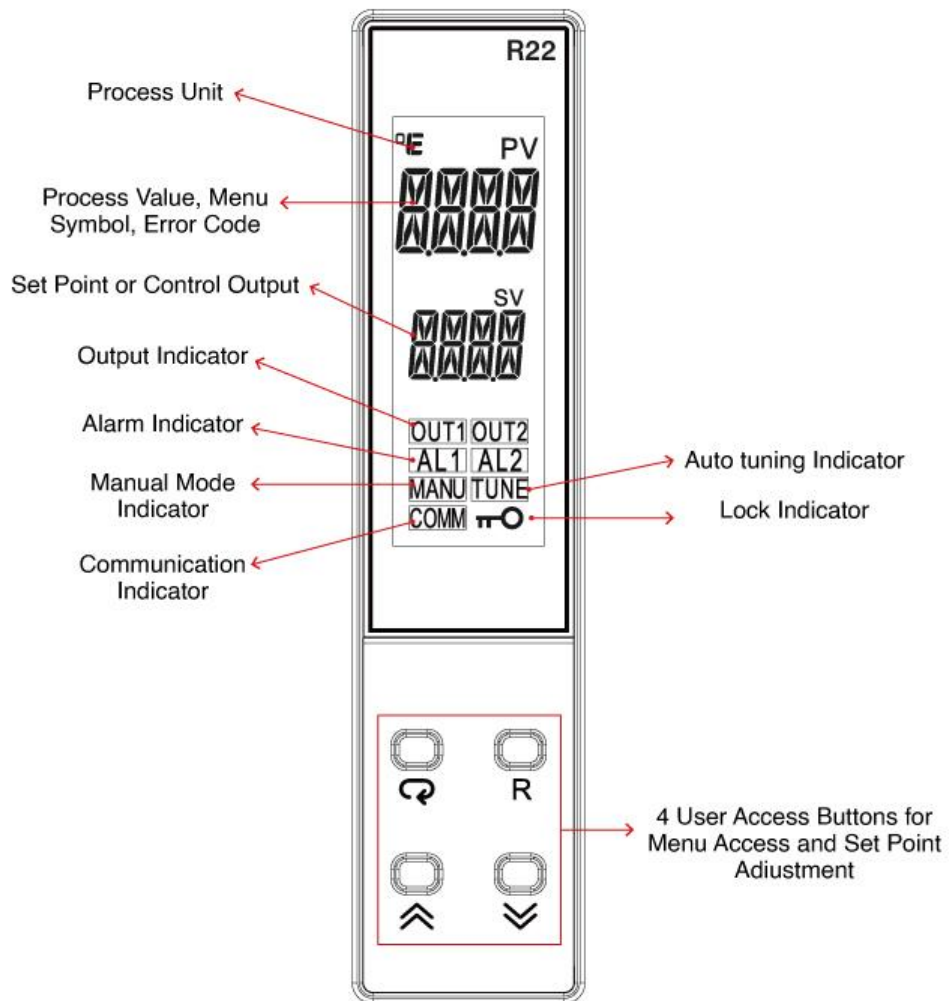

**1-11 R22 Front Panel Keys and Display**

A A	B b	C C	D d	E E	F F	G G
H H	I I	J J	K K	L L	M M	N N
O o	P P	Q Q	R R	S S	T T	U U
V V	W W	X X	Y Y	Z Z		

1-12 How Characters are Displayed on the LCD screen

### 1.7 Menu Flowchart

The Menu has been divided into 5 groups. They are as follows:

1. User Menu
2. Setup Menu
3. Manual Mode Menu
4. Auto-Tuning Mode Menu
5. Calibration Mode Menu

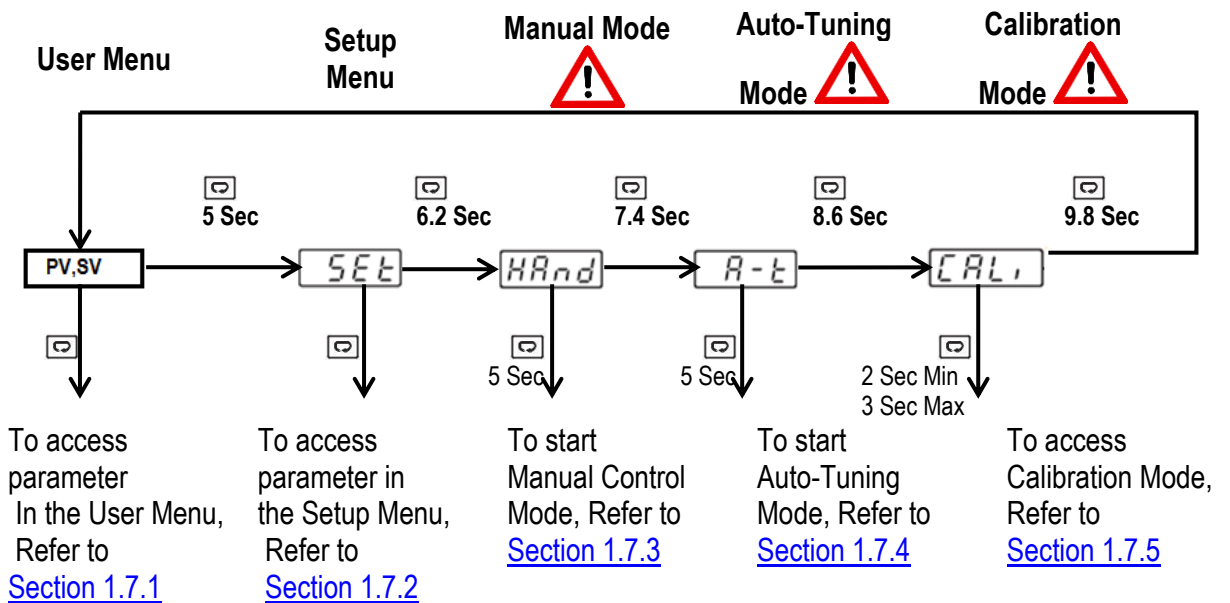

Press for the next parameter  
 Press and key to return to the previous parameter.

#### 1.7.1 User Menu

The below user menu parameters are available depends on the user selection.

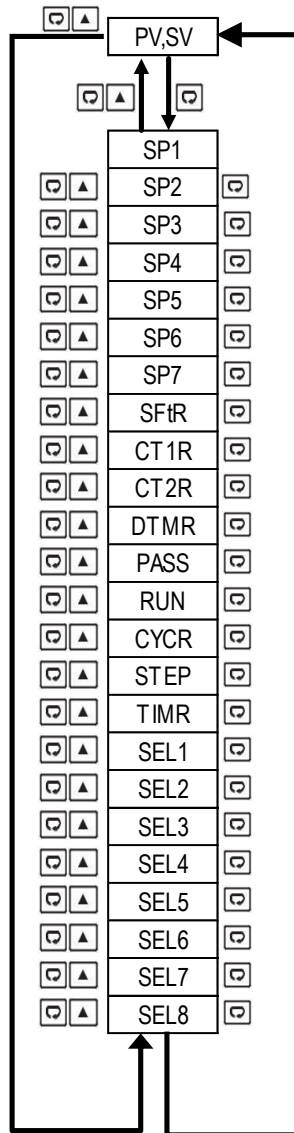

## 1.7.2 Setup Menu

The setup menu has been categorized into eight categories. They are listed as below.

1. Basic Menu
2. Output Menu
3. Alarm Menu
4. Event Input Menu
5. User Select Menu
6. Communication Menu
7. Current Transformer Input Menu
8. Profile Menu

### 1.7.2.1 Basic Menu (bASE)



Use ▲ or ▼ key to get bASE in the lower display then use ◀ key to enter to basic menu parameters.

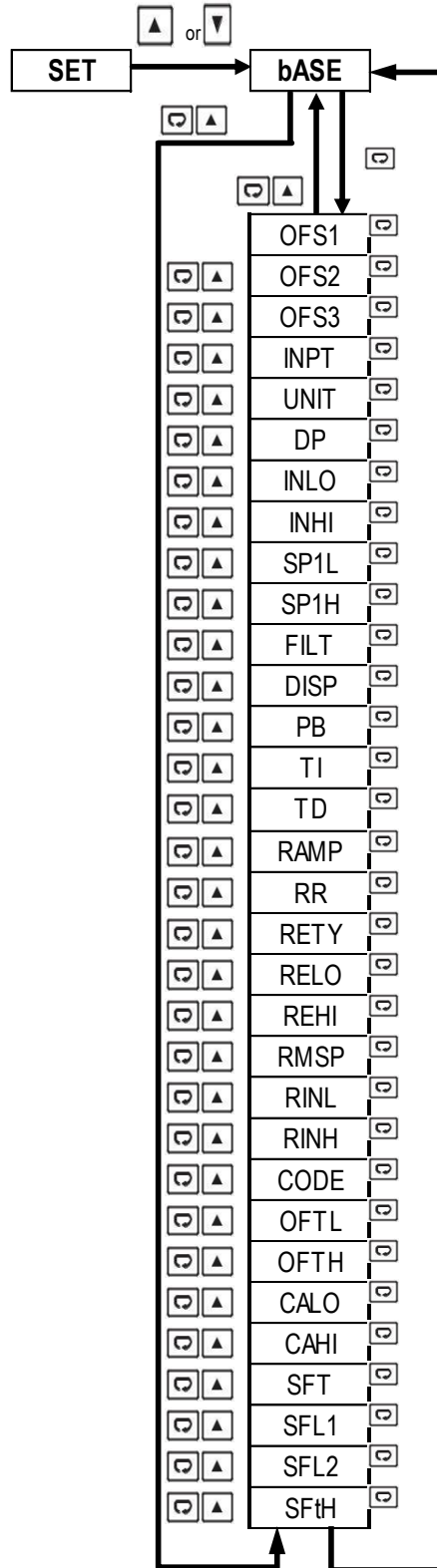

### 1.7.2.2 Output Menu (oUT)

Use ▲ or ▼ key to get oUT in the lower display then use □ key to enter to output menu parameters.

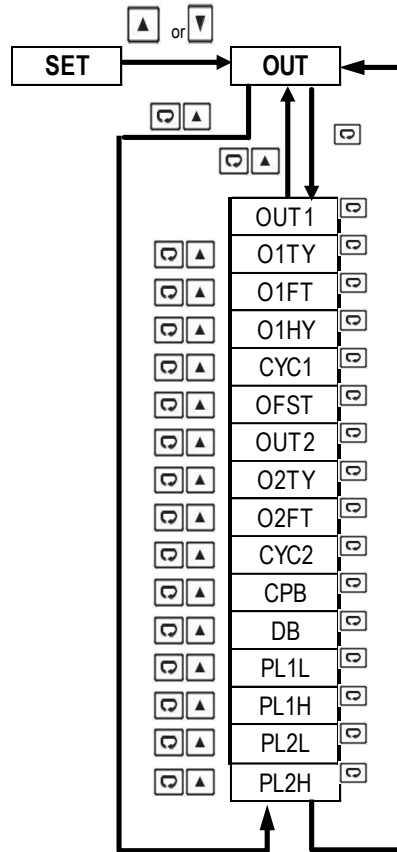

### 1.7.2.3 Event Input Menu (EI)

Use ▲ or ▼ key to get EI in the lower display then use □ key to enter to event input menu parameters.

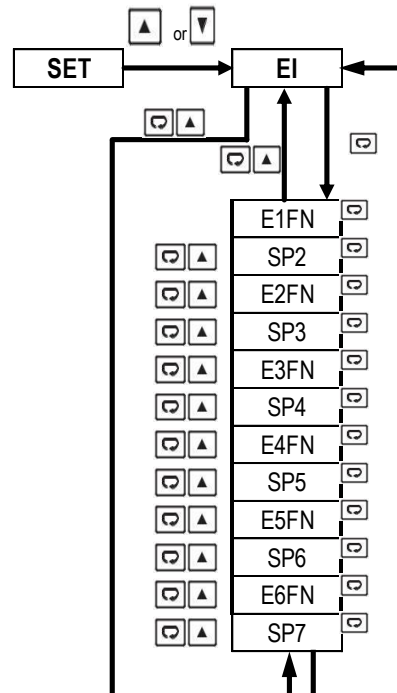

### 1.7.2.4 Alarm Menu (ALRM)



Use ▲ or ▼ key to get ALRM in the lower display then use ◀ key to enter to alarm menu parameters.

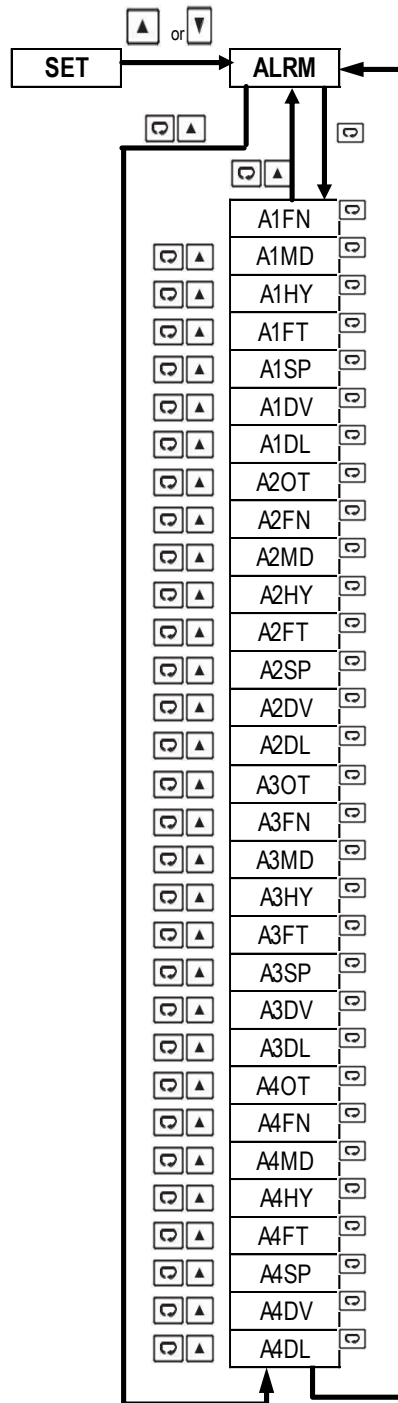

### 1.7.2.5 User Select Menu (SEL)

Use ▲ or ▼ key to get SEL in the lower display then use ⏏ key to enter to select the user menu parameters.

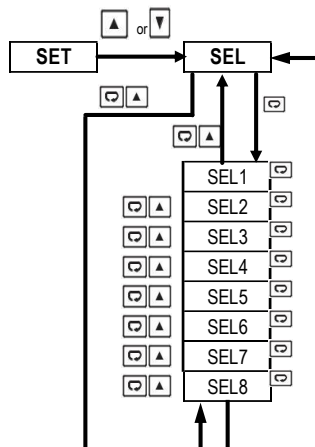

### 1.7.2.6 Communication Menu (CoMM)

Use ▲ or ▼ key to get CoMM in the lower display then use ⏏ key to enter into communication menu parameters.

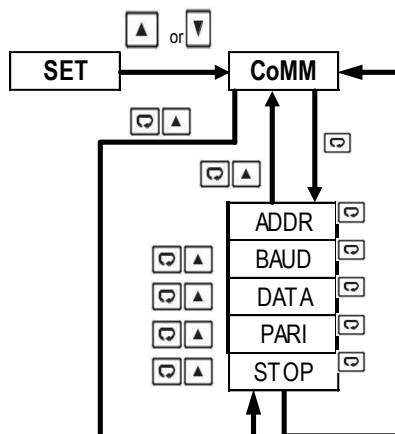

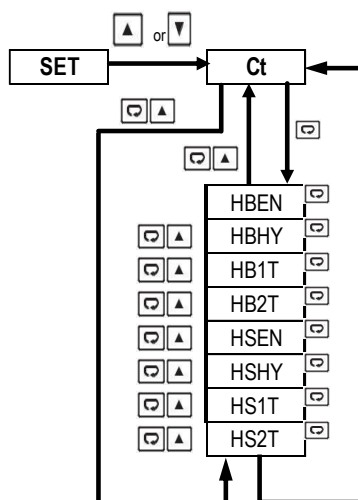

### 1.7.2.7 Current Transformer Input Menu (Ct)

Use ▲ or ▼ key to get Ct in the lower display then use ⏏ key to enter into Current transformer (CT) input menu parameters.



### 1.7.2.8 Profile Menu (PRoF)

Use  or  key to get PRoF in the lower display then use  key to enter into Profile menu parameters.

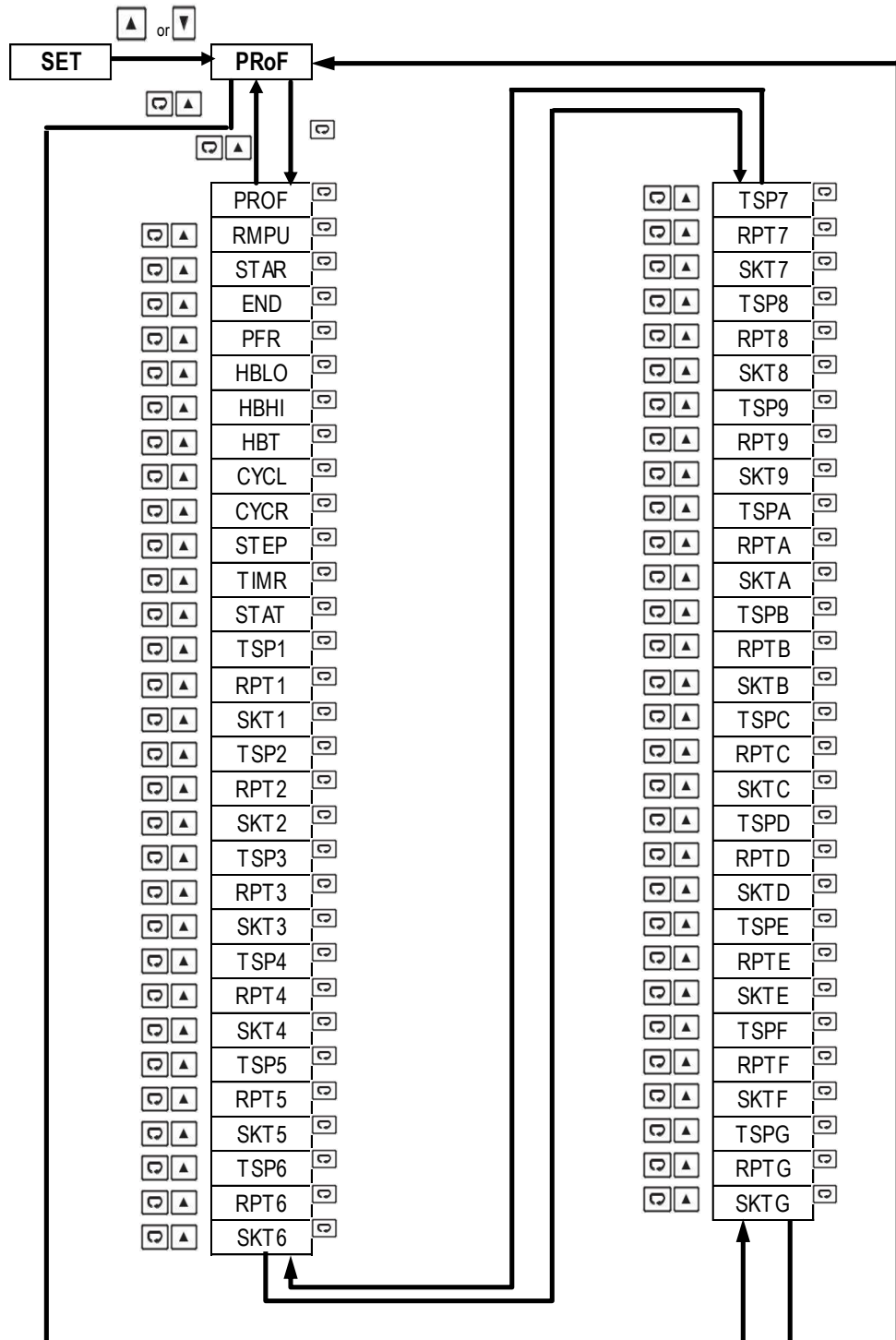

### 1.7.3 Manual Mode Menu

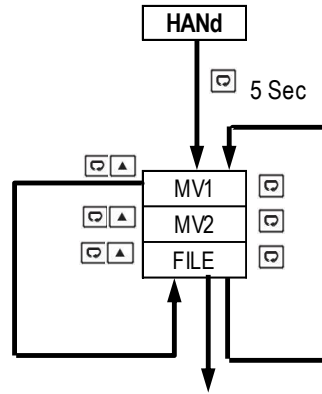

Press key 5 Sec To execute the selected default program

### 1.7.4 Auto-Tuning Mode

**A-t**

Press key 5 seconds to activate Auto-Tuning Mode

### 1.7.5 Calibration Mode

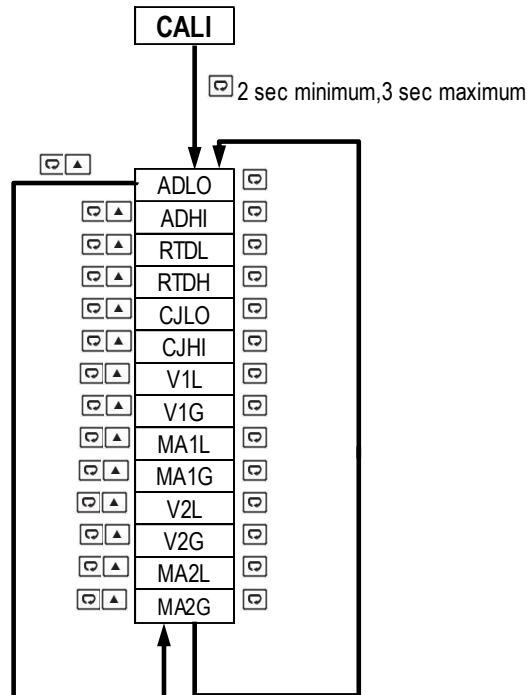

Press key for 2 seconds or longer (not more than 3 seconds) then release it to enter calibration Mode.  
Press Key for 5 seconds to perform calibration.

**Note:**

- Using Manual, Auto-Tuning, Calibration modes will break the control loop and change some of the previous setting data. Make sure that the system is allowable to apply these modes.
- The flow chart shows a complete list of all parameters. For actual application, the number of available parameters will vary depending on the setup and model of the controller and will be less than that shown in the flow chart.
- The user can select up to 8 parameters to put in the user select menu by using the SEL1~SEL8 parameters in the setup menu

### 1.8 Parameter Availability Table

Register Address	Parameter Notation	C22	C62	C82	C83	C72	C42	R22	Existence Conditions
0	SP1	V	V	V	V	V	V	V	Exists unconditionally
1	SP2	V	V	V	V	V	V	V	<b>C42/C82/C83/C72:</b> Exists if E1FN selects SP2 <b>C62/R22:</b> Exists if E1FN exists and E1FN selects SP2
2	SP3		V	V	V	V	V	V	<b>C42/C82/C83/C72:</b> Exists if E2FN selects SP3 <b>C62/R22:</b> Exists if E2FN exists and E2FN selects SP3
3	SP4			V	V		V		Exists if E3FN selects SP4
4	SP5			V	V		V		Exists if E4FN selects SP5
5	SP6			V	V		V		Exists if E5FN selects SP6
6	SP7			V	V		V		Exists if E6FN selects SP7
7	DTMR	V	V	V	V	V	V	V	<b>C42/C82/C83:</b> Exists if A1FN selects DTMR or A2FN selects DTMR or A3FN selects DTMR or A4FN selects DTMR <b>C72:</b> Exists if A1FN selects DTMR or A2FN selects DTMR or A3FN selects DTMR or OFS3 selects AL4 and A4FN selects DTMR <b>C62:</b> Exists if A1FN selects DTMR or A2FN selects DTMR or OFS3 selects ALM3 and A3FN selects DTMR <b>C22/R22:</b> Exists if A1FN selects DTMR or A2FN selects DTMR
8	INPT	V	V	V	V	V	V	V	Exists unconditionally
9	UNIT	V	V	V	V	V	V	V	Exists unconditionally
10	DP	V	V	V	V	V	V	V	Exists unconditionally
11	INLO	V	V	V	V	V	V	V	Exists if INPT selects 4-20, 0-20, 0-5V, 1-5V, 0-10 or 0-50
12	INHI	V	V	V	V	V	V	V	
13	SP1L	V	V	V	V	V	V	V	Exists unconditionally
14	SP1H	V	V	V	V	V	V	V	Exists unconditionally
15	FILT	V	V	V	V	V	V	V	Exists unconditionally
16	DISP			V	V	V	V		Exists unconditionally
17	PB	V	V	V	V	V	V	V	Exists unconditionally
18	TI	V	V	V	V	V	V	V	Exists if PB1 ≠ 0
19	TD	V	V	V	V	V	V	V	
20	OUT1	V	V	V	V	V	V	V	Exists unconditionally
21	O1TY	V	V	V	V	V	V	V	Exists unconditionally
22	O1FT	V	V	V	V	V	V	V	Exists unconditionally
23	O1HY	V	V	V	V	V	V	V	Exists if PB1 = 0
24	CYC1	V	V	V	V	V	V	V	Exists if PB1 ≠ 0
25	OFST	V	V	V	V	V	V	V	Exists if PB1 ≠ 0 and TI = 0
26	RAMP	V	V	V	V	V	V	V	Exists unconditionally
27	RR	V	V	V	V	V	V	V	Exists if RAMP selects MINR or HRR
28	OUT2	V	V	V	V	V	V	V	Exists unconditionally
29	O2TY	V	V	V	V	V	V	V	Exists if OUT2 selects COOL or AL1 or RAL1
30	O2FT	V	V	V	V	V	V	V	
31	CYC2	V	V	V	V	V	V	V	Exists if OUT2 selects COOL
32	CPB	V	V	V	V	V	V	V	
33	DB	V	V	V	V	V	V	V	
34	A1FN	V	V	V	V	V	V	V	Exists if OUT2 selects AL1 or RAL1
35	A1MD	V	V	V	V	V	V	V	<b>C42/C82/C83/C72:</b> Exists if OUT2 selects AL1 or RAL1 and A1FN selects DTMR, DEHI, DELO, DBHI, DBLO, PVHI, PVLO, H. BK, H.ST, RG.HI, RG. LO, RG.H.L, PFHB, PFED <b>C62/C22/R22:</b> Exists if OUT2 selects AL1 or RAL1 and A1FN selects DTMR, DEHI, DELO, DBHI, DBLO, PVHI, PVLO, H. BK, H.ST, RG.HI, RG. LO, RG.H.L

Register Address	Parameter Notation	C22	C62	C82	C83	C72	C42	R22	Existence Conditions
36	A1HY	V	V	V	V	V	V	V	Exists if OUT2 selects AL1 or RAL1 and A1FN selects DEHI, DELO, DBHI, DBLO, PVHI, PVLO, RG.HI, RG.LO, RG.H.L
37	A1FT	V	V	V	V	V	V	V	Exists if OUT2 selects AL1 or RAL1 and A1FN selects DTMR, DEHI, DELO, DBHI, DBLO, PVHI, PVLO, RG.HI, RG.LO, RG.H.L
38	A1SP	V	V	V	V	V	V	V	Exists if OUT2 selects AL1 or RAL1 and A1FN selects PVHI, PVLO, RG.HI, RG.LO, RG.H.L
39	A1DV	V	V	V	V	V	V	V	Exists if OUT2 selects AL1 or RAL1 and A1FN selects DEHI, DELO, DBHI, DBLO, RG.HI, RG.LO, RG.H.L
40	A2OT	V	V	V	V	V	V	V	<b>C42/C82/C83/C72/C62:</b> Exists unconditionally <b>C22/R22:</b> Exists if OFS2 selects AL2
41	A2FN	V	V	V	V	V	V	V	<b>C42/C82/C83/C72/C62:</b> Exists unconditionally <b>C22/R22:</b> Exists if OFS2 selects AL2
42	A2MD	V	V	V	V	V	V	V	<b>C42/C82/C83/C72/C62:</b> Exists if A2FN selects DTMR, DEHI, DELO, DBHI, DBLO, PVHI, PVLO, H. BK, H.ST, RG.HI, RG. LO, RG.H.L, PFHB, PFED, E1.C.O, or E2.C.O <b>C22/R22:</b> Exists if OFS2 selects AL2 and A2FN selects DTMR, DEHI, DELO, DBHI, DBLO, PVHI, PVLO, H. BK, H.ST, RG.HI, RG. LO, RG.H.L, E1.C.O or E2.C.O
43	A2HY	V	V	V	V	V	V	V	<b>C42/C82/C83/C72/C62:</b> Exists if A2FN selects DEHI, DELO, DBHI, DBLO, PVHI, PVLO, RG.HI, RG.LO, RG.H.L <b>C22/R22:</b> Exists if OFS2 selects AL2 and A2FN selects DEHI, DELO, DBHI, DBLO, PVHI, PVLO, RG.HI, RG.LO, RG.H.L
44	A2FT	V	V	V	V	V	V	V	<b>C42/C82/C83/C72/C62:</b> Exists if A2FN selects DTMR, DEHI, DELO, DBHI, DBLO, PVHI, PVLO, RG.HI, RG.LO, RG.H.L <b>C22/R22:</b> Exists if OFS2 selects AL2 and A2FN selects DTMR, DEHI, DELO, DBHI, DBLO, PVHI, PVLO, RG.HI, RG.LO, RG.H.L
45	A2SP	V	V	V	V	V	V	V	<b>C42/C82/C83/C72/C62:</b> Exists if A2FN selects PVHI, PVLO, RG.HI, RG.LO, RG.H.L <b>C22/R22:</b> Exists if OFS2 selects AL2 and A2FN selects PVHI, PVLO, RG.HI, RG.LO, RG.H.L
46	A2DV	V	V	V	V	V	V	V	<b>C42/C82/C83/C72/C62:</b> Exists if A2FN selects DEHI, DELO, DBHI, DBLO, RG.HI, RG.LO, RG.H.L <b>C22/R22:</b> Exists if OFS2 selects AL2 and A2FN selects DEHI, DELO, DBHI, DBLO, RG.HI, RG.LO, RG.H.L
47	A3OT		V	V	V	V	V		<b>C82/C83/C72/C42:</b> Exists unconditionally
48	A3FN		V	V	V	V	V		<b>C62:</b> Exists if OFS3 is set to ALM3
49	A3MD		V	V	V	V	V		<b>C82/C83/C72/C42:</b> Exists if A3FN is set to DTMR, DEHI, DELO, DBHI, DBLO, PVHI, PVLO, H. BK, H.ST, RG.HI, RG. LO, RG.H.L, PFHB, PFED <b>C62:</b> Exists if OFS3 s is set to ALM3, or if A3FN is set to DTMR, DEHI, DELO, DBHI, DBLO, PVHI, PVLO, H. BK, H.ST, RG.HI, RG. LO, RG.H.L

Register Address	Parameter Notation	C22	C62	C82	C83	C72	C42	R22	Existence Conditions
50	A3HY		V	V	V	V	V		<b>C82/C83/C72/C42:</b> Exists if A3FN is set to DEHI, DELO, DBHI, DBLO, PVHI, PVLO, H. BK, H.ST, RG.HI, RG. LO, RG.H.L, <b>C62:</b> Exists if OFS3 is set to ALM3, or if A3FN is set to DEHI, DELO, DBHI, DBLO, PVHI, PVLO, H. BK, H.ST, RG.HI, RG. LO, RG.H.L,
51	A3FT		V	V	V	V	V		<b>C82/C83/C72/C42:</b> Exists if A3FN is set to DTMR, DEHI, DELO, DBHI, DBLO, PVHI, PVLO, H. BK, H.ST, RG.HI, RG. LO, RG.H.L, <b>C62:</b> Exists if OFS3 is set to ALM3, or if A3FN is set to DTMR, DEHI, DELO, DBHI, DBLO, PVHI, PVLO, H. BK, H.ST, RG.HI, RG. LO, RG.H.L,
52	A3SP		V	V	V	V	V		<b>C82/C83/C72/C42:</b> Exists if A3FN is set to PVHI, PVLO, RG.HI, RG. LO, RG.H.L, <b>C62:</b> Exists if OFS3 is set to ALM3, or if A3FN is set, PVHI, PVLO, RG.HI, RG. LO, RG.H.L,
53	A3DV		V	V	V	V	V		<b>C82/C83/C72/C42:</b> Exists if A3FN is set to DEHI, DELO, DBHI, DBLO, RG.HI, RG. LO, RG.H.L, <b>C62:</b> Exists if OFS3 is set to ALM3, or if A3FN is set to DEHI, DELO, DBHI, DBLO, PVHI, PVLO, RG.HI, RG. LO, RG.H.L,
54	A4OT			V	V	V	V		<b>C42/C82/C83:</b> Exists if OFS3 selects A.4.20, A.0.20, A.0.5V, A.1.5V or A.0.10 <b>C72:</b> Exists if OFS3 selects AL4
55	A4FN			V	V	V	V		
56	A4MD			V	V	V	V		<b>C42/C82/C83:</b> Exists if OFS3 selects A.4.20, A.0.20, A.0.5V, A.1.5V, or A.0.10 and A4FN selects DTMR, DEHI, DELO, DBHI, DBLO, PVHI, PVLO, H. BK, H.ST, RG.HI, RG. LO, RG.H.L, PFHB, PFED <b>C72:</b> Exists if OFS3 selects AL4 and A4FN selects DTMR, DEHI, DELO, DBHI, DBLO, PVHI, PVLO, H. BK, H.ST, RG.HI, RG. LO, RG.H.L, PFHB, PFED
57	A4HY			V	V	V	V		<b>C42/C82/C83:</b> Exists if OFS3 selects A.4.20, A.0.20, A.0.5V, A.1.5V or A.0.10 and A4FN selects DEHI, DELO, DBHI, DBLO, PVHI, PVLO, H. BK, H.ST, RG.HI, RG. LO, RG.H.L, <b>C72:</b> Exists if OFS3 selects AL4 and A4FN selects DEHI, DELO, DBHI, DBLO, PVHI, PVLO, H. BK, H.ST, RG.HI, RG. LO, RG.H.L,
58	A4FT			V	V	V	V		<b>C42/C82/C83:</b> Exists if OFS3 selects A.4.20, A.0.20, A.0.5V, A.1.5V or A.0.10 and A4FN selects DTMR, DEHI, DELO, DBHI, DBLO, PVHI, PVLO, H. BK, H.ST, RG.HI, RG. LO, RG.H.L <b>C72:</b> Exists if OFS3 selects AL4 and A4FN selects DTMR, DEHI, DELO, DBHI, DBLO, PVHI, PVLO, H. BK, H.ST, RG.HI, RG. LO, RG.H.L
59	A4SP			V	V	V	V		<b>C42/C82/C83:</b> Exists if OFS3 selects A.4.20, A.0.20, A.0.5V, A.1.5V or A.0.10 and A4FN selects PVHI, PVLO, RG.HI, RG. LO, RG.H.L, <b>C72:</b> Exists if OFS3 selects AL4 and A4FN selects PVHI, PVLO, RG.HI, RG. LO, RG.H.L,

Register Address	Parameter Notation	C22	C62	C82	C83	C72	C42	R22	Existence Conditions
60	A4DV			V	V	V	V		<b>C42/C82/C83:</b> Exists if OFS3 selects A.4.20, A.0.20, A.0.5V, A.1.5V or A.0.10 and A4FN selects DEHI, DELO, DBHI, DBLO, RG.HI, RG.LO, RG.H.L <b>C72:</b> Exists if OFS3 selects AL4 and A4FN selects DEHI, DELO, DBHI, DBLO, RG.HI, RG.LO, RG.H.L
61	BPL1	V	V	V	V	V	V	V	Exists unconditionally
62	BPL2	V	V	V	V	V	V	V	Exists unconditionally
63	CJCL	V	V	V	V	V	V	V	Exists unconditionally
64	PV64	V	V	V	V	V	V	V	Exists unconditionally
65	SV65	V	V	V	V	V	V	V	Exists unconditionally
66	MV166	V	V	V	V	V	V	V	Exists unconditionally
67	MV267	V	V	V	V	V	V	V	Exists if OUT2 selects COOL
68	TIMER	V	V	V	V	V	V	V	Exists unconditionally
69	EROR	V	V	V	V	V	V	V	Exists unconditionally
70	MODE	V	V	V	V	V	V	V	Exists unconditionally
71	PROG71	V	V	V	V	V	V	V	Exists unconditionally
72	CMND	V	V	V	V	V	V	V	Exists unconditionally
73	JOB1	V	V	V	V	V	V	V	Exists unconditionally
74	JOB2	V	V	V	V	V	V	V	Exists unconditionally
75	JOB3	V	V	V	V	V	V	V	Exists unconditionally
76	CJCT	V	V	V	V	V	V	V	Exists unconditionally
77	ADLO	V	V	V	V	V	V	V	Exists unconditionally
78	ADHI	V	V	V	V	V	V	V	Exists unconditionally
79	RTDL	V	V	V	V	V	V	V	Exists unconditionally
80	RTDH	V	V	V	V	V	V	V	Exists unconditionally
81	CJLO	V	V	V	V	V	V	V	Exists unconditionally
82	CJHI	V	V	V	V	V	V	V	Exists unconditionally
83	V1L	V	V	V	V	V	V	V	Exists unconditionally
84	V1G	V	V	V	V	V	V	V	Exists unconditionally
85	MA1L	V	V	V	V	V	V	V	Exists unconditionally
86	MA1G	V	V	V	V	V	V	V	Exists unconditionally
87	V2L			V	V	V	V		Exists if OFS1 does not select NONE and OFS2 does not select NONE and OFS3 does not select NONE
88	V2G			V	V	V	V		
89	MA2L			V	V	V	V		
90	MA2G			V	V	V	V		Exists if OFS1 does not select NONE and OFS2 does not select NONE and OFS3 does not select NONE
91	PL1L	V	V	V	V	V	V	V	Exists if PB1≠ 0
92	PL1H	V	V	V	V	V	V	V	
93	PL2L	V	V	V	V	V	V	V	Exists if OUT2 selects COOL
94	PL2H	V	V	V	V	V	V	V	
95	SEL1	V	V	V	V	V	V	V	Exists unconditionally
96	SEL2	V	V	V	V	V	V	V	Exists unconditionally
97	SEL3	V	V	V	V	V	V	V	Exists unconditionally
98	SEL4	V	V	V	V	V	V	V	Exists unconditionally
99	SEL5	V	V	V	V	V	V	V	Exists unconditionally
100	SEL6	V	V	V	V	V	V	V	Exists unconditionally
101	SEL7	V	V	V	V	V	V	V	Exists unconditionally
102	SEL8	V	V	V	V	V	V	V	Exists unconditionally
103	OFS1	V	V	V	V	V	V	V	Exists unconditionally
104	OFS2	V	V	V	V	V	V	V	Exists unconditionally
105	OFS3		V	V	V	V	V		Exists unconditionally
106	RETY	V	V	V	V	V	V	V	<b>C42/C82/C83:</b> Exists if OFS3 selects 4-20, 0-20, 0-5V, 1-5V, 0-10, A.4.20, A.0.20, A.0.5V,
107	RELO	V	V	V	V	V	V	V	



Register Address	Parameter Notation	C22	C62	C82	C83	C72	C42	R22	Existence Conditions
108	REHI	V	V	V	V	V	V	V	A.1.5V, or A.0.10 <b>C72/C62:</b> Exists if OFS3 selects 4-20, 0-20, 0-5V, 1-5V, 0-10 <b>C22/R22:</b> Exists if OFS2 selects 4-20, 0-20, 0-5V, 1-5V, 0-10
109	ADDR	V	V	V	V	V	V	V	Exists if OFS1 selects RS-485
110	BAUD	V	V	V	V	V	V	V	
111	DATA	V	V	V	V	V	V	V	
112	PARI	V	V	V	V	V	V	V	
113	STOP	V	V	V	V	V	V	V	
114	CT1R	V	V	V	V	V	V	V	<b>C42/C82/C83/C72:</b> Exists if OFS2 selects CT1 or CT1.2 <b>C62:</b> Exists if OFS2 selects CT1.2 <b>C22/R22:</b> Exists if OFS1 select CT1
115	CT2R		V	V	V	V	V	V	<b>C42/C82/C83/C72:</b> Exists if OFS2 selects CT1.2 <b>C62:</b> Exists if OFS2 selects EI. CT or CT1.2 <b>R22:</b> Exists if OFS2 selects CT2
116	HBEN	V	V	V	V	V	V	V	<b>C42/C82/C83/C72:</b> Exists if OFS2 selects CT1 or CT1.2 <b>C62:</b> Exists if OFS2 selects EI. CT or CT1.2 <b>C22:</b> Exists if OFS1 selects CT1 <b>R22:</b> Exists if OFS1 selects CT1 or OFS2 selects CT2
117	HBHY	V	V	V	V	V	V	V	Exists if HBEN is exist and HBEN selects ON
118	HB1T	V	V	V	V	V	V	V	Exists if CT1R exists and HBEN selects ON
119	HB2T		V	V	V	V	V	V	Exists if CT2R exists and HBEN selects ON
120	HSEN	V	V	V	V	V	V	V	<b>C42/C82/C83/C72:</b> Exists if OFS2 selects CT1 or CT1.2 <b>C62:</b> Exists if OFS2 selects EI. CT or CT1.2 <b>C22:</b> Exists if OFS1 selects CT1 <b>R22:</b> Exists if OFS1 selects CT1 or OFS2 selects CT2
121	HSYH	V	V	V	V	V	V	V	Exists if HSEN exists and HSEN selects ON
122	HS1T	V	V	V	V	V	V	V	Exists if CT1R exists and HSEN selects ON
123	HS2T		V	V	V	V	V	V	Exists if CT2R exists and HSEN selects ON
124	RMSP			V	V	V	V		<b>C42/C82/C83/C72:</b> Exists if OFS1 and OFS2 and OFS3 are not all select "None" <b>C62/C22/R22:</b> Not exist
125	RINL			V	V	V	V		
126	RINH			V	V	V	V		
127	FILE	V	V	V	V	V	V	V	Exists unconditionally
128	PV	V	V	V	V	V	V	V	Exists unconditionally
129	SV	V	V	V	V	V	V	V	Exists unconditionally
130	MV1	V	V	V	V	V	V	V	Exists unconditionally
131	MV2	V	V	V	V	V	V	V	Exists if OUT2 selects COOL
132	PASS	V	V	V	V	V	V	V	Exists unconditionally
133	CODE	V	V	V	V	V	V	V	Exists unconditionally
134	OFTL	V	V	V	V	V	V	V	Exists unconditionally
135	OFTH	V	V	V	V	V	V	V	Exists unconditionally
136	CALO	V	V	V	V	V	V	V	Exists unconditionally
137	CAHI	V	V	V	V	V	V	V	Exists unconditionally
138	...	...	...	...	...	...	...	...	...
139	PRON	V	V	V	V	V	V	V	Exists with Firmware up to V20
140	PROG	V	V	V	V	V	V	V	Exists unconditionally
141	E1FN	V	V	V	V	V	V	V	<b>C42/C82/C83/C72:</b> Exists unconditionally <b>C62:</b> Exists if OFS2 selects EI12 or EICT <b>C22/R22:</b> Exists if OFS1 selects EI1
142	E2FN		V	V	V	V	V	V	<b>C42/C82/C83/C72:</b> Exists unconditionally <b>C62:</b> Exists if OFS2 selects EI12 <b>R22:</b> Exists if OFS2 selects EI2

Register Address	Parameter Notation	C22	C62	C82	C83	C72	C42	R22	Existence Conditions
143	E3FN			V	V		V		<b>C42/C82/C83:</b> Exists unconditionally <b>C72/C62/C22/R22:</b> Not exist
144	E4FN			V	V		V		
145	E5FN			V	V		V		
146	E6FN			V	V		V		
147	A1DL	V	V	V	V	V	V	V	Exists if OUT2 selects AL1 or RAL1
148	A2DL	V	V	V	V	V	V	V	<b>C42/C82/C83/C72/C62:</b> Exists unconditionally <b>C22/R22:</b> Exist if OFS2 selects AL2
149	A3DL		V	V	V	V	V		<b>C42/C82/C83/C72:</b> Exists unconditionally <b>C62:</b> Exists if OFS3 selects ALM3
150	A4DL			V	V	V	V		<b>C42/C82/C83:</b> Exists if OFS3 selects A.4.20, A.0.20, A.0.5V, A.1.5V or A.0.10 <b>C72:</b> Exists if OFS3 selects AL4
151	SFT	V	V	V	V	V	V	V	Exists unconditionally
152	SFL1	V	V	V	V	V	V	V	Exists if SFT does not select OFF
153	SFL2	V	V	V	V	V	V	V	Exists if SFT does not select OFF
154	SFTH	V	V	V	V	V	V	V	Exists if SFT does not select OFF
155	SFTR	V	V	V	V	V	V	V	Exists if SFT does not select OFF
156	...								
157	...								
158	...								
159	...								
160	...								
161	PROF			V	V	V	V		<b>C42/C82/C83/C72:</b> Exists unconditionally <b>C62/C22/R22:</b> Not exist
162	RUN			V	V	V	V		<b>C42/C82/C83/C72:</b> Exists if PROF≠0 <b>C62/C22/R22:</b> Not exist
163	RMPU			V	V	V	V		
164	STAR			V	V	V	V		
165	END			V	V	V	V		
166	PFR			V	V	V	V		
167	HBLO			V	V	V	V		
168	HBHI			V	V	V	V		
169	HBT			V	V	V	V		
170	CYCL			V	V	V	V		
171	CYCR			V	V	V	V		
172	STEP			V	V	V	V		
173	TIMR			V	V	V	V		
174	STAT			V	V	V	V		
175	TSP1			V	V	V	V		<b>C42/C82/C83/C72:</b> Exists if PROF selects 1 or 3 or 7 <b>C62/C22/R22:</b> Not exist
176	RPT1			V	V	V	V		
177	SKT1			V	V	V	V		
178	TSP2			V	V	V	V		
179	RPT2			V	V	V	V		
180	SKT2			V	V	V	V		
181	TSP3			V	V	V	V		
182	RPT3			V	V	V	V		
183	SKT3			V	V	V	V		
184	TSP4			V	V	V	V		
185	RPT4			V	V	V	V		<b>C42/C82/C83/C72:</b> Exists if PROF selects 2 or 3 or 7 <b>C62/C22/R22:</b> Not exist
186	SKT4			V	V	V	V		
187	TSP5			V	V	V	V		
188	RPT5			V	V	V	V		
189	SKT5			V	V	V	V		
190	TSP6			V	V	V	V		
191	RPT6			V	V	V	V		
192	SKT6			V	V	V	V		<b>C42/C82/C83/C72:</b> Exists if PROF selects 2 or 3 or 7
193	TSP7			V	V	V	V		
194	RPT7			V	V	V	V		
195	SKT7			V	V	V	V		

Register Address	Parameter Notation	C22	C62	C82	C83	C72	C42	R22	Existence Conditions
196	TSP8			V	V	V	V		C62/C22/R22: Not exist
197	RPT8			V	V	V	V		
198	SKT8			V	V	V	V		
199	TSP9			V	V	V	V		C42/C82/C83/C72: Exists if PROF selects 4 or 6 or 7 C62/C22/R22: Not exist
200	RPT9			V	V	V	V		
201	SKT9			V	V	V	V		
202	TSPA			V	V	V	V		
203	RPTA			V	V	V	V		
204	SKTA			V	V	V	V		
205	TSPB			V	V	V	V		
206	RPTB			V	V	V	V		
207	SKTB			V	V	V	V		
208	TSPC			V	V	V	V		
209	RPTC			V	V	V	V		
210	SKTC			V	V	V	V		
211	TSPD			V	V	V	V		C42/C82/C83/C72: Exists if PROF selects 5 or 6 or 7 C62/C22/R22: Not exist
212	RPTD			V	V	V	V		
213	SKTD			V	V	V	V		
214	TSPE			V	V	V	V		
215	RPTE			V	V	V	V		
216	SKTE			V	V	V	V		
217	TSPF			V	V	V	V		
218	RPTF			V	V	V	V		
219	SKTF			V	V	V	V		
220	TSPG			V	V	V	V		
221	RPTG			V	V	V	V		
222	SKTG			V	V	V	V		

### 1-2 Parameter Availability

#### 1.9 Parameters Description

Modbus Register Address	Parameter Notation	Parameter Description	Range	Default Value	Data Access Type	Scale (Unsigned 16 Bit Data)	
						Low	High
0	SP1	Set Point 1	Low: SP1L High: SP1H	25.0°C (77.0°F)	R/W	-19999	45536
1	SP2	Set Point 2	Low: SP1L High: SP1H	100.0°C (212.0°F)	R/W	-19999	45536
2	SP3	Set Point 3	Low: SP1L High: SP1H	100.0°C (212.0°F)	R/W	-19999	45536
3	SP4	Set Point 4	Low: SP1L High: SP1H	100.0°C (212.0°F)	R/W	-19999	45536
4	SP5	Set Point 5	Low: SP1L High: SP1H	100.0°C (212.0°F)	R/W	-19999	45536
5	SP6	Set Point 6	Low: SP1L High: SP1H	100.0°C (212.0°F)	R/W	-19999	45536
6	SP7	Set Point 7	Low: SP1L High: SP1H	100.0°C (212.0°F)	R/W	-19999	45536
7	DTMR	Dwell timer output time (Minutes: Seconds)	Low: 0.0 High: 4553.5	0.0	R/W	-19999	45536

Modbus Register Address	Parameter Notation	Parameter Description	Range	Default Value	Data Access Type	Scale (Unsigned 16 Bit Data)	
						Low	High
8	INPT	Input sensor selection	<b>0 J_tC:</b> J type Thermocouple <b>1 K_tC:</b> K type Thermocouple <b>2 t_tC:</b> T type Thermocouple <b>3 E_tC:</b> E type Thermocouple <b>4 b_tC:</b> B type Thermocouple <b>5 R_tC:</b> R type Thermocouple <b>6 S_tC:</b> S type Thermocouple <b>7 N_tC:</b> N type Thermocouple <b>8 L_tC:</b> L type Thermocouple <b>9 U_tC:</b> U type Thermocouple <b>10 P_tC:</b> P type Thermocouple <b>11 C_tC:</b> C type Thermocouple <b>12 d_tC:</b> D type Thermocouple <b>13 Pt. dN:</b> PT100 Ω DIN curve <b>14 Pt.JS:</b> PT100 Ω JIS curve <b>15 4-20:</b> 4-20mA linear current <b>16 0-20:</b> 0-20mA linear current <b>17 0-5V:</b> 0-5VDC linear voltage <b>18 1-5V:</b> 1-5VDC linear voltage <b>19 0-10:</b> 0-10VDC linear voltage <b>20 0-50:</b> 0-50mVDC linear voltage <b>21 LJtC:</b> Land and Jewel thermocouple(Not available for C22, C62 & R22)	1	R/W	0	65535
9	UNIT	Input unit selection	<b>0 oC:</b> °C unit <b>1 oF:</b> °F unit <b>2 Pu:</b> Process unit	0	R/W	0	65535
10	DP	Decimal point selection	<b>0 No. dP:</b> No decimal point <b>1 1-dP:</b> 1 decimal digit <b>2 2-dP:</b> 2 decimal digits <b>3 3-dP:</b> 3 decimal digits	1	R/W	0	65535
11	INLO	Input low scale value	Low: -19999 High: INHI	-17.8°C (0.0°F)	R/W	-19999	45536
12	INHI	Input high scale value	Low: INLO+1 High: 45536	93.3°C (200.0°F)	R/W	-19999	45536
13	SP1L	Low limit of set point value	Low: -19999 High :SP1H	-17.8°C (0.0° F)	R/W	-19999	45536
14	SP1H	High limit of set point value	Low: SP1L High: 45536	537.8°C (1000.0°F)	R/W	-19999	45536
15	FILT	Filter damping time constant of PV	<b>0 0:</b> 0 second time constant <b>1 0.2:</b> 0.2 second time constant <b>2 0.5:</b> 0.5 second time constant <b>3 1:</b> 1 second time constant <b>4 2:</b> 2 second time constant <b>5 5:</b> 5 second time constant <b>6 10:</b> 10 second time constant <b>7 20:</b> 20 second time constant <b>8 30:</b> 30 second time constant <b>9 60:</b> 60 second time constant	2	R/W	0	65535
16	DISP	MV/TIME display selection	<b>0 None:</b> No Display <b>1 MV1:</b> Display MV1 (66/130) <b>2 MV2:</b> Display MV2(67/131) <b>3 tMR:</b> Display Time (68) <b>4 PRoF:</b> display STAT (162) if have profile function	1	R/W	0	65535

Modbus Register Address	Parameter Notation	Parameter Description	Range	Default Value	Data Access Type	Scale (Unsigned 16 Bit Data)	
						Low	High
17	PB	Proportional band value	Low: 0.0 High: 500.0°C (900.0°F)	40.0°C (72.0°F)	R/W	0	65535
18	TI	Integral time value	Low: 0 High: 3600 sec	60	R/W	0	65535
19	TD	Derivative time value	Low: 0.0 High: 360.0 sec	15	R/W	0	65535
20	OUT1	Output 1 function	0 <b>REVR</b> : Reverse (heating) control action 1 <b>dIRt</b> : Direct (cooling) control action	0	R/W	0	65535
21	O1TY	Output 1 signal type	0 <b>RELY</b> : Relay output 1 <b>SSrd</b> : Solid state relay drive output 2 <b>4-20</b> : 4-20mA linear current 3 <b>0-20</b> : 0-20mA linear current 4 <b>0-5V</b> : 0-5VDC linear voltage 5 <b>1-5V</b> : 1-5VDC linear voltage 6 <b>0-10</b> : 0-10VDC linear voltage	0	R/W	0	65535
22	O1FT	Output 1 failure transfer mode	Select BPLS (Bumpless transfer), or 0.0 ~ 100.0 % to continue output 1 control function if the sensor fails, or select OFF (0) or ON (1) for ON-OFF control	0	R/W	-19999	45536
23	O1HY	Output 1 ON-OFF control hysteresis	Low: 0.1°C (0.2°F) High: 50.0°C (90.0°F)	0.1° C (0.2 °F)	R/W	0	65535
24	CYC1	Output 1 cycle time	Low: 0.1 High: 90.0 sec.	18	R/W	0	65535
25	OFST	Offset value for P control	Low: 0 High: 100.0 %	25	R/W	0	65535
26	RAMP	Ramp function selection	0 <b>NoNE</b> : No Ramp Function 1 <b>MINR</b> : Use unit/minute as Ramp Rate 2 <b>HRR</b> : Use unit/hour as Ramp Rate	0	R/W	0	65535
27	RR	Ramp rate	Low: 0.0 High: 500.0°C (900.0°F)	0	R/W	0	65535
28	OUT2	Output 2 function	0 <b>NoNE</b> : Output2 turned off 1 <b>COOL</b> : Cooling PID Function 2 <b>AL1</b> : Alarm 1 Function 3 <b>rAL1</b> : Reverse Alarm 1 Function 4 <b>DCPS</b> :DC Transmitter Power Supply	2	R/W	0	65535
29	O2TY	Output 2 signal type	0 <b>RELY</b> : Relay output 1 <b>SSrd</b> : Solid state relay drive output 2 <b>4-20</b> : 4-20mA linear current 3 <b>0-20</b> : 0-20mA linear current 4 <b>0-5V</b> : 0-5VDC linear voltage 5 <b>1-5V</b> : 1-5VDC linear voltage 6 <b>0-10</b> : 0-10VDC linear voltage	0	R/W	0	65535
30	O2FT	Output 2 failure transfer mode	Select BPLS (Bumpless transfer), or 0.0 ~ 100.0 % to	0	R/W	-19999	45536

Modbus Register Address	Parameter Notation	Parameter Description	Range	Default Value	Data Access Type	Scale (Unsigned 16 Bit Data)	
						Low	High
			continue output 2 control function if the sensor fails				
31	CYC2	Output 2 cycle time	Low: 0.1 High: 90.0 sec.	18	R/W	0	65535
32	CPB	Cooling proportional band value	Low: 50 High: 300 %	100	R/W	0	65535
33	DB	Heating-cooling dead band (negative value= overlap)	Low: - 36.0 High: 36.0 %	0	R/W	-19999	45536
34	A1FN	Alarm 1 function for alarm 1 output	<b>0 NoNE:</b> No alarm function <b>1 dtMR:</b> Dwell timer action <b>2 dE.HI:</b> Deviation high alarm <b>3 dE.Lo:</b> Deviation low alarm <b>4 db.HI:</b> Deviation band out of band alarm <b>5 db.Lo:</b> Deviation band in band alarm <b>6 PV.HI:</b> Process value high alarm <b>7 PV. Lo:</b> Process value low alarm <b>8 H.bK:</b> Heater break alarm <b>9 H.St:</b> Heater short alarm <b>12 RG.HI:</b> Range Hi alarm <b>13 RG.Lo:</b> Range Low alarm <b>14 RG.H.L:</b> RangeHi-Low alarm <b>15 PF.Hb:</b> Profile Holdback alarm <b>16 PF.Ed:</b> Profile End alarm	2	R/W	0	65535
35	A1MD	Alarm 1 operation mode	<b>0 NoRM:</b> Normal alarm action <b>1 LtCH:</b> Latching alarm action <b>2 HoLd:</b> Hold alarm action <b>3 Lt.Ho:</b> Latching & Hold action <b>4 SP.Ho:</b> Setpoint holding alarm <b>5 Lt.N.R:</b> Latching None Reset action	0	R/W	0	65535
36	A1HY	Alarm 1 Hysteresis control	Low: 0.1°C High: 50.0°C(90.0°F)	0.1 °C (0.2 °F)	R/W	0	65535
37	A1FT	Alarm 1 failure transfer mode	<b>0 OFF:</b> Alarm output OFF if the sensor fails <b>1 ON:</b> Alarm output ON if the sensor fails	0	R/W	0	65535
38	A1SP	Alarm 1 set point	Low: -19999 High: 45536	100.0 °C (212.0°F)	R/W	-19999	45536
39	A1DV	Alarm 1 deviation value	Low: -19999 High: 45536	10.0 °C (18.0°F)	R/W	-19999	45536
40	A2OT	Alarm 2 Output	<b>0 ALM:</b> Alarm 2 output <b>1 RALM:</b> Reverse Alarm 2 Output	0	R/W	0	65535

Modbus Register Address	Parameter Notation	Parameter Description	Range	Default Value	Data Access Type	Scale (Unsigned 16 Bit Data)	
						Low	High
41	A2FN	Alarm 2 functions for alarm 2 output	<b>0 NoNE:</b> No alarm function <b>1 dtMR:</b> Dwell timer action <b>2 dE.HI:</b> Deviation high alarm <b>3 dE.Lo:</b> Deviation low alarm <b>4 db.HI:</b> Deviation band out of band alarm <b>5 db.Lo:</b> Deviation band in band alarm <b>6 PV.HI:</b> Process value high alarm <b>7 PV.Lo:</b> Process value low alarm <b>8 H.bK:</b> Heater break alarm <b>9 H.St:</b> Heater short alarm <b>10 E1.C.o:</b> Event Input 1 Control Alarm Output <b>11 E2.C.o:</b> Event Input 2 Control Alarm Output <b>12 RG.HI:</b> Range Hi alarm <b>13 RG.Lo:</b> Range Low alarm <b>14 RG.H.L:</b> Range Hi-Low alarm <b>15 PF.Hb:</b> Profile Holdback alarm <b>16 PF.Ed:</b> Profile End alarm	2	R/W	0	65535
42	A2MD	Alarm 2 operation mode	<b>0 NoRM:</b> Normal alarm action <b>1 LtCH:</b> Latching alarm action <b>2 HoLd:</b> Hold alarm action <b>3 Lt.Ho:</b> Latching & Hold action <b>4 SP.Ho:</b> Set point holding alarm <b>5 Lt.N.R:</b> Latching None Reset action	0	R/W	0	65535
43	A2HY	Alarm 2 Hysteresis control	Low: 0.1°C High: 50.0°C(90.0°F)	0.1° C (0.2° F)	R/W	0	65535
44	A2FT	Alarm 2 failure transfer mode	<b>0 OFF:</b> Alarm output OFF if the sensor fails <b>1 ON:</b> Alarm output ON if the sensor fails	0	R/W	0	65535
45	A2SP	Alarm 2 set point	Low: -19999 High: 45536	100.0 °C (212.0°F)	R/W	-19999	45536
46	A2DV	Alarm 2 deviation value	Low: -19999 High: 45536	10.0°C (18.0 °F)	R/W	-19999	45536
47	A3OT	Alarm 3 output	<b>0 ALM:</b> Alarm 3 output <b>1 RALM:</b> Reverse Alarm3 Output	0	R/W	0	65535

Modbus Register Address	Parameter Notation	Parameter Description	Range	Default Value	Data Access Type	Scale (Unsigned 16 Bit Data)	
						Low	High
48	A3FN	Alarm 3 functions for alarm 3 output	<b>0 NoNE:</b> No alarm function <b>1 dtMR:</b> Dwell timer action <b>2 dE.HI:</b> Deviation high alarm <b>3 dE.Lo:</b> Deviation low alarm <b>4 db.HI:</b> Deviation band out of band alarm <b>5 db.Lo:</b> Deviation band in band alarm <b>6 PV.HI:</b> Process value high alarm <b>7 PV.Lo:</b> Process value low alarm <b>8 H.bK:</b> Heater break alarm <b>9 H.St:</b> Heater short alarm <b>10 E1.C.o:</b> Event Input 1 Control Alarm Output <b>11 E2.C.o:</b> Event Input 2 Control Alarm Output <b>12 RG.HI:</b> Range Hi alarm <b>13 RG.Lo:</b> Range Low alarm <b>14 RG.H.L:</b> Range Hi-Low alarm <b>15 PF.Hb:</b> Profile Holdback alarm <b>16 PF.Ed:</b> Profile End alarm	2	R/W	0	65535
49	A3MD	Alarm 3 operation mode	<b>0 NoRM:</b> Normal alarm action <b>1 LtCH:</b> Latching alarm action <b>2 HoLd:</b> Hold alarm action <b>3 Lt.Ho:</b> Latching & Hold action <b>4 SP.Ho:</b> Set point holding alarm <b>5 Lt.N.R:</b> Latching None Reset action	0	R/W	0	65535
50	A3HY	Alarm 3 Hysteresis control	Low: 0.1°C High: 50.0°C(90.0°F)	0.1°C (0.2°F)	R/W	0	65535
51	A3FT	Alarm 3 failure transfer mode	<b>0 OFF:</b> Alarm output OFF if the sensor fails <b>1 ON:</b> Alarm output ON if the sensor fails	0	R/W	0	65535
52	A3SP	Alarm 3 set point	Low: -19999 High: 45536	100.0°C (212.0°F)	R/W	-19999	45536
53	A3DV	Alarm 3 deviation value	Low: -19999 High: 45536	10.0°C (18.0°F)	R/W	-19999	45536
54	A4OT	Alarm 4 output	<b>0 ALM:</b> Alarm 4 output <b>1 RALM:</b> Reverse Alarm 4 Output	0	R/W	0	65535



Modbus Register Address	Parameter Notation	Parameter Description	Range	Default Value	Data Access Type	Scale (Unsigned 16 Bit Data)	
						Low	High
55	A4FN	Alarm 4 function for alarm output	<b>0 NoNE:</b> No alarm function <b>1 dtMR:</b> Dwell timer action <b>2 dE.HI:</b> Deviation high alarm <b>3 dE.Lo:</b> Deviation low alarm <b>4 db.HI:</b> Deviation band out of band alarm <b>5 db.Lo:</b> Deviation band in band alarm <b>6 PV.HI:</b> Process value high alarm <b>7 PV. Lo:</b> Process value low alarm <b>8 H.bK:</b> Heater break alarm <b>9 H.St:</b> Heater short alarm <b>12 RG.HI:</b> Range Hi alarm <b>13 RG.Lo:</b> Range Low alarm <b>14 RG.H.L:</b> Range Hi-Low alarm <b>15 PF.Hb:</b> Profile Holdback alarm <b>16 PF.Ed:</b> Profile End alarm	2	R/W	0	65535
56	A4MD	Alarm 4 operation mode	<b>0 NoRM:</b> Normal alarm action <b>1 LtCH:</b> Latching alarm action <b>2 HoLd:</b> Hold alarm action <b>3 Lt.Ho:</b> Latching & Hold action <b>4 SP.Ho:</b> Setpoint holding alarm <b>5 Lt.N.R:</b> Latching None Reset action	0	R/W	0	65535
57	A4HY	Alarm 4 Hysteresis control	Low: 0.1°C High: 50.0°C(90.0°F)	0.1 °C (0.2°F)	R/W	0	65535
58	A4FT	Alarm 4 failure transfer mode	<b>0 OFF:</b> Alarm output OFF if the sensor fails <b>1 ON:</b> Alarm output ON if the sensor fails	0	R/W	0	65535
59	A4SP	Alarm 4 set point	Low: -19999 High: 45536	100.0°C (212.0°F)	R/W	-19999	45536
60	A4DV	Alarm 4 deviation value	Low: -19999 High: 45536	10.0 °C (18.0 °F)	R/W	-19999	45536
61	BPL1	Bumpless transfer value of MV1	Low: 0.00 High: 100.00	-----	R	0	65535
62	BPL2	Bumpless transfer value of MV2	Low: 0.00 High: 100.00	-----	R	0	65535
63	CJCL	Sense voltage during cold junction calibration low	Low: 0 High: 7552	-----	R	0	65535
64	PV64	Process value	Low: -19999 High: 45536	-----	R	-19999	45536
65	SV65	Current set point value	Low: SP1L High: SP1H	-----	R	-19999	45536

Modbus Register Address	Parameter Notation	Parameter Description	Range	Default Value	Data Access Type	Scale (Unsigned 16 Bit Data)	
						Low	High
66	MV1 66	Output 1 %Value (Heating)	Low: 0.00 High: 100.00 %	----	R (R/W, Manual)	0	65535
67	MV2 67	Output 2 %Value (Cooling)	Low: 0.00 High: 100.00 %	----	R (R/W, Manual)	0	65535
68	TIMER	Remaining time of dwell timer	Low: 0.0 High: 4553.6	----	R	-19999	45536
69	EROR	Error code	Low: 0 High: 65535	----	R	0	65535
70	MODE	Operation mode & alarm status	Low: 0 High: 65535	----	R	0	65535
71	PROG71	Program code	C22:22. XX C62:62. XX C82:82. XX C82(Profile):84.XX C83:83. XX C83(Profile):85.XX C72:72. XX C72(Profile):73.XX C42:42. XX C42(Profile):44.XX R22:23. XX	----	R	0	65535
72	CMND	Command code	Low: 0 High: 65535	----	R/W	0	65535
73	JOB1	Job code	Low: 0 High: 65535	----	R/W	0	65535
74	JOB2	Job code	Low: 0 High: 65535	----	R/W	0	65535
75	JOB3	Job code	Low: 0 High: 65535	----	R/W	0	65535
76	CJCT	Cold Junction Temperature	Low: -4000 High: 9000	----	R	-19999	45536
77	ADLO	mV calibration low coefficient	Low: -1999 High: 1999	----	R/W	-19999	45536
78	ADHI	mV calibration high coefficient	Low: -1999 High: 1999	----	R/W	-19999	45536
79	RTDL	RTD calibration low coefficient	Low: -1999 High: 1999	----	R/W	-19999	45536
80	RTDH	RTD calibration high coefficient	Low: -1999 High: 1999	----	R/W	-19999	45536
81	CJLO	Cold junction calibration low coefficient	Low: -5.00 High: 40.00	----	R/W	-19999	45536
82	CJHI	Cold junction calibration high coefficient	Low: -1999 High: 1999	----	R/W	-19999	45536
83	V1L	V1 calibration low coefficient	Low: -1999 High: 1999	----	R/W	-19999	45536
84	V1G	V1 calibration high coefficient	Low: -1999 High: 1999	----	R/W	-19999	45536
85	MA1L	MA1 calibration low coefficient	Low: -1999 High: 1999	----	R/W	-19999	45536

Modbus Register Address	Parameter Notation	Parameter Description	Range	Default Value	Data Access Type	Scale (Unsigned 16 Bit Data)	
						Low	High
86	MA1G	MA1 calibration high coefficient	Low: -1999 High: 1999	-----	R/W	-19999	45536
87	V2L	V2 calibration low coefficient	Low: -1999 High: 1999	-----	R/W	-19999	45536
88	V2G	V2 calibration high coefficient	Low: -1999 High: 1999	-----	R/W	-19999	45536
89	MA2L	MA2 calibration low coefficient	Low: -1999 High: 1999	-----	R/W	-19999	45536
90	MA2G	MA2 calibration high coefficient	Low: -1999 High: 1999	-----	R/W	-19999	45536
91	PL1L	Power limit Output1 low	Low: 0 High: PL1H or 50%	0	R/W	0	65535
92	PL1H	Power limit Output1 high	Low: PL1L High: 100 %	100	R/W	0	65535
93	PL2L	Power limit Output2 low	Low: 0 High: PL2H or 50%	0	R/W	0	65535
94	PL2H	Power limit Output2 high	Low: PL2L High: 100 %	100	R/W	0	65535
95	SEL1	1'st parameter for the user menu	<b>0 NoNE:</b> No Parameter <b>1 dtMR:</b> DTMR <b>2 dISP:</b> DISP <b>3 Pb:</b> PB <b>4 tl:</b> TI <b>5 td:</b> TD <b>6 o1HY:</b> O1HY <b>7 RR:</b> RR <b>8 CPb:</b> CPB <b>9 db:</b> DB <b>10 A1HY:</b> A1HY <b>11 A1SP:</b> A1SP <b>12 A1dV:</b> A1DV <b>13 A2HY:</b> A2HY <b>14 A2SP:</b> A2SP <b>15 A2dV:</b> A2DV <b>16 A3HY:</b> A3HY <b>17 A3SP:</b> A3SP <b>18 A3dV:</b> A3DV <b>19 A4HY:</b> A4HY <b>20 A4SP:</b> A4SP <b>21 A4dV:</b> A4DV <b>22 PL1L:</b> PL1L <b>23 PL1H:</b> PL1H <b>24 PL2L:</b> PL2L <b>25 PL2H:</b> PL2H <b>26 OFTL:</b> OFTL <b>27 OFTH:</b> OFTH <b>28 CALO:</b> CALO <b>29 CAHI:</b> CAHI <b>30 A1DL:</b> A1DL <b>31 A2DL:</b> A2DL <b>32 A3DL:</b> A3DL <b>33 A4DL:</b> A4DL <b>34 UNIT:</b> UNIT	0	R/W	0	65535

Modbus Register Address	Parameter Notation	Parameter Description	Range	Default Value	Data Access Type	Scale (Unsigned 16 Bit Data)	
						Low	High
96	SEL2	2'nd parameter for the user menu	Same as SEL1	0	R/W	0	65535
97	SEL3	3'rd parameter for the user menu	Same as SEL1	0	R/W	0	65535
98	SEL4	4'th parameter for the user menu	Same as SEL1	0	R/W	0	65535
99	SEL5	5'th parameter for the user menu	Same as SEL1	0	R/W	0	65535
100	SEL6	6'th parameter for the user menu	Same as SEL1	0	R/W	0	65535
101	SEL7	7'th parameter for the user menu	Same as SEL1	0	R/W	0	65535
102	SEL8	8'th parameter for the user menu	Same as SEL1	0	R/W	0	65535
103	OFS1	Option 1	<b>C82/C83/C72/C42:</b> <b>0 NoNE:</b> Not selected <b>1 R485:</b> RS-485 with unsigned integer data on Modbus and Remote SP <b>2 S16b:</b> RS485 with signed integer data on Modbus and Remote SP	0	R/W	0	65535
			<b>C62:</b> <b>0 NoNE:</b> Not selected <b>1 R485:</b> RS-485 with unsigned integer data on Modbus <b>2 S16b:</b> RS485 with signed integer data on Modbus				
			<b>C22/R22:</b> <b>0 NoNE:</b> Not selected <b>1 R485:</b> RS-485 with unsigned integer data on Modbus <b>2 EI1:</b> Event 1 input <b>3 CT1:</b> CT 1 input <b>4 S16b:</b> RS485 with signed integer data on Modbus				
104	OFS2	Option 2	<b>C82/C83/C72/C42:</b> <b>0 NoNE:</b> Not selected <b>1 CT1:</b> CT1 input and Remote SP <b>2 CT1.2:</b> CT1, CT2 inputs and Remote SP	0	R/W	0	65535

Modbus Register Address	Parameter Notation	Parameter Description	Range	Default Value	Data Access Type	Scale (Unsigned 16 Bit Data)	
						Low	High
			<u><b>C62:</b></u> <b>0 NoNE:</b> Not selected <b>1 EI1.2:</b> Event input 1 and Event input 2 <b>2 EI. CT:</b> Event input 1 and CT2 input <b>3 CT1.2:</b> CT1 and CT2 inputs				
			<u><b>C22:</b></u> <b>0.NoNE:</b> No selected <b>1.4-20:</b> 4-20mA retransmission output <b>2. 0-20:</b> 0-20mA retransmission output <b>3. 0-5V:</b> 0-5V retransmission output <b>4. 1-5V:</b> 1-5V retransmission output <b>5. 0-10:</b> 0-10 retransmission output <b>6.AL2:</b> Alarm 2 output				
			<u><b>R22:</b></u> <b>0.NoNE:</b> No selected <b>1.4-20:</b> 4-20mA retransmission output <b>2. 0-20:</b> 0-20mA retransmission output <b>3. 0-5V:</b> 0-5V retransmission output <b>4. 1-5V:</b> 1-5V retransmission output <b>5. 0-10:</b> 0-10 retransmission output <b>6.AL2:</b> Alarm 2 output <b>7.EI2:</b> Event2 Input <b>8.CT2:</b> CT2 Input				

Modbus Register Address	Parameter Notation	Parameter Description	Range	Default Value	Data Access Type	Scale (Unsigned 16 Bit Data)	
						Low	High
105	OFS3	Option 3	<u>C82/C83/C42:</u> <b>0</b> <i>NoNE</i> : Not selected <b>1</b> <b>4-20</b> : 4-20mA retransmission output and Remote SP <b>2</b> <b>0-20</b> : 0-20mA retransmission output and Remote SP <b>3</b> <b>0-5V</b> : 0-5VDC retransmission output and Remote SP <b>4</b> <b>1-5V</b> : 1-5VDC retransmission output and Remote SP <b>5</b> <b>0-10</b> : 0-10VDC retransmission output and Remote SP <b>6</b> <b>A.4.20</b> : Alarm 4, 4-20mA retransmission output and Remote SP <b>7</b> <b>A.0.20</b> : Alarm 4, 0-20mA retransmission output and Remote SP <b>8</b> <b>A.0.5V</b> : Alarm 4,0-5V retransmission output and Remote SP <b>9</b> <b>A.1.5V</b> : Alarm 4,1-5V retransmission output and Remote SP <b>10</b> <b>A.0.10</b> : Alarm 4, 0-10V retransmission output and Remote SP	0	R/W	0	65535
			<u>C72:</u> <b>0</b> <i>NoNE</i> : Not selected <b>1</b> <b>4-20</b> : 4-20mA retransmission output and Remote SP <b>2</b> <b>0-20</b> : 0-20mA retransmission output and Remote SP <b>3</b> <b>0-5V</b> : 0-5VDC retransmission output and Remote SP <b>4</b> <b>1-5V</b> : 1-5VDC retransmission output and Remote SP <b>5</b> <b>0-10V</b> : 0-10VDC retransmission output and Remote SP <b>6</b> <b>AL4</b> : Alarm 4 Output				

Modbus Register Address	Parameter Notation	Parameter Description	Range	Default Value	Data Access Type	Scale (Unsigned 16 Bit Data)	
						Low	High
			<b>C62:</b> <b>0 NONE:</b> Not selected <b>1 4-20:</b> 4-20mA retransmission output <b>2 0-20:</b> 0-20mA retransmission output <b>3 0-5V:</b> 0-5VDC retransmission output <b>4 1-5V:</b> 1-5VDC retransmission output <b>5 0-10:</b> 0-10VDC retransmission output <b>6 AL3:</b> Alarm 3 output				
106	RETY	Retransmission type	<b>0 RE.PV:</b> Retransmit process value <b>1 RE.SP:</b> Retransmit set point value	0	R/W	0	65535
107	RELO	Retransmission low scale value	Low: -19999 High: 45536	0.0°C (32.0°F)	R/W	-19999	45536
108	REHI	Retransmission high scale value	Low: -19999 High: 45536	100.0 °C (212.0 °F)	R/W	-19999	45536
109	ADDR	Address assignment of digital communication	Low: 1 High: 255	-----	R/W	0	65535
110	BAUD	Baud rate of digital communication	<b>0 2K4:</b> 2.4 Kbits/s baud rate <b>1 4K8:</b> 4.8 Kbits/s baud rate <b>2 9K6:</b> 9.6 Kbits/s baud rate <b>3 14K4:</b> 14.4 Kbits/s baud rate <b>4 19K2:</b> 19.2 Kbits/s baud rate <b>5 28K8:</b> 28.8 Kbits/s baud rate <b>6 38K4:</b> 38.4 Kbits/s baud rate <b>7 57K6:</b> 57.6 Kbits/s baud rate <b>8 115K:</b> 115.2 Kbits/s baud rate	2	R/W	0	65535
111	DATA	Data bit count of digital communication	<b>0 7blt:</b> 7 data bits <b>1 8blt:</b> 8 data bits	1	R/W	0	65535
112	PARI	The parity bit of digital communication	<b>0 EVEN:</b> Even Parity <b>1 Odd:</b> Odd parity <b>2 NONE:</b> No parity bit	0	R/W	0	65535
113	STOP	Stop bit count of digital communication	<b>0 1blt:</b> One stop bit <b>1 2blt:</b> Two stop bits	0	R/W	0	65535
114	CT1R	Reading of CT 1	Low: 0.0 High: 150.0	0.0	R	0	65535
115	CT2R	Reading of CT 2	Low: 0.0 High: 150.0	0.0	R	0	65535
116	HBEN	Enable Heater break detection	<b>0 oFF:</b> Off <b>1 oN:</b> On	0	R/W	0	65535

Modbus Register Address	Parameter Notation	Parameter Description	Range	Default Value	Data Access Type	Scale (Unsigned 16 Bit Data)	
						Low	High
117	HBHY	Heater break hysteresis	Low: 0.1 High: 50.0	0.1	R/W	0	65535
118	HB1T	Triple point current for heater break 1	Low: 0.0 High: 120.0	0.0	R/W	0	65535
119	HB2T	Triple point current for heater break 2	Low: 0.0 High: 120.0	0.0	R/W	0	65535
120	HSEN	Enable Heater short detection	<b>0</b> <b>oFF</b> : Off <b>1</b> <b>oN</b> : On	0	R/W	0	65535
121	HSHY	Heater short hysteresis	Low: 0.1 High: 50.0	0.1	R/W	0	65535
122	HS1T	Triple point current for heater short 1	Low: 0.0 High: 120.0	50.0	R/W	0	65535
123	HS2T	Triple point current for heater short 2	Low: 0.0 High: 120.0	50.0	R/W	0	65535
124	RMSP	Remote SP type	<b>0 None</b> : No Remote SP <b>1 4-20</b> : 4-20mA Remote SP <b>2 0-20</b> : 0-20mA Remote SP <b>3 0-5V</b> : 0-5VDC Remote SP <b>4 1-5V</b> : 1-5VDC Remote SP <b>5 0-10</b> : 0-10VDC Remote SP	0	R/W	0	65535
125	RINL	Remote SP Input low scale value	Low: -19999 High: RINH-50	-17.8°C (0.0°F)	R/W	-19999	45536
126	RINH	Remote SP Input high scale value	Low: RINL+50 High: 45536	93.3°C (200.0°F)	R/W	-19999	45536
127	FILE	Default File Selection	<b>0 dFLt</b> : Default Menu <b>1 Ld.Us</b> : Load User Setting <b>2 St.Us</b> : Store User Setting	0	R/W	0	65535
128	PV	Process value	Low: -19999 High: 45536	-----	R	-19999	45536
129	SV	Current set point value	Low: SP1L High: SP1H	-----	R	-19999	45536
130	MV1	Output 1 percentage value (Heating)	Low: 0.00 High: 100.00	-----	R (R/W, manual mode)	0	65535
131	MV2	Output 2 percentage value (Cooling)	Low: 0.00 High: 100.00	-----	R (R/W, manual mode)	0	65535
132	PASS	Password entry	Low: 0 High: 9999	0	R/W	0	65535
133	CODE	Security code for parameter protection	Low: 0 High: 9999 Refer <a href="#">Chapter 3.1</a> for more details	0	R/W	0	65535



Modbus Register Address	Parameter Notation	Parameter Description	Range	Default Value	Data Access Type	Scale (Unsigned 16 Bit Data)	
						Low	High
134	OFTL	Offset value for low point calibration	Low: -1999 High: 1999	0	R/W	-19999	45536
135	OFTH	Offset value for high point calibration	Low: -1999 High: 1999	0	R/W	-19999	45536
136	CALO	Input signal value during low point calibration	Low: -19999 High: CAHI-1	0	R/W	-19999	45536
137	CAHI	Input signal value during high point calibration	Low: CALO+1 High: 45536	1000	R/W	-19999	45536
138	...	Reserved	...	...	...	...	...
139	PRON	Switch On/Off the Output and Alarm during booting (Exist with FW V20 or up)	<b>0 DIS:</b> The PRON is disable. <b>1 RUN:</b> Output/Alarm ON <b>2 OFF:</b> Output/Alarm OFF	0	R/W	0	65535
140	PROG	Program code	Same as PROG71	-----	R	0	65535
141	E1FN	Event input 1 function	<b>0 NoNE:</b> none <b>1 SP2:</b> SP2 activated to replace SP1 <b>2 rS.A1:</b> Reset alarm 1 output <b>3 rS.A2:</b> Reset alarm 2 output <b>4 rS.A3:</b> Reset alarm 3 output <b>5 rS.A4:</b> Reset alarm 4 output <b>6 rS.Ao:</b> Reset all alarm outputs <b>7 CA.LH:</b> Cancel alarm latch <b>8 d.o1:</b> Disable output 1 <b>9 d.o2:</b> Disable output 2 <b>10 d.o12:</b> Disable output 1 & 2 <b>11 LoCK:</b> Lock all parameters and Read-only communication <b>12 AU.MA:</b> Switch Auto and Manual control mode <b>13 F.tra:</b> Failure Transfer <b>14 AL.oN:</b> EI Control Alarm Output <b>20 d.R.SP:</b> Disable Remote Setpoint	0	R/W	0	65535
142	E2FN	Event input 2 function	<b>1 SP3:</b> SP3 activated to replace SP1 <b>Others:</b> Same as E1FN	0	R/W	0	65535

Modbus Register Address	Parameter Notation	Parameter Description	Range	Default Value	Data Access Type	Scale (Unsigned 16 Bit Data)	
						Low	High
143	E3FN	Event input 3 function	<b>0 NoNE:</b> none <b>1 SP4:</b> SP4 activated to replace SP1 <b>2 rS.A1:</b> Reset alarm 1 output <b>3 rS.A2:</b> Reset alarm 2 output <b>4 rS.A3:</b> Reset alarm 3 output <b>5 rS.A4:</b> Reset alarm 4 output <b>6 rS.Ao:</b> Reset all alarm outputs <b>7 CA.LH:</b> Cancel alarm latch <b>8 d.o1:</b> Disable output 1 <b>9 d.o2:</b> Disable output 2 <b>10 d.o12:</b> Disable output 1& 2 <b>11 LoCK:</b> Lock all parameters and Read-only communication <b>12 AU.MA:</b> Switch Auto and Manual control mode <b>13 F.tra:</b> Failure Transfer <b>15 StAR:</b> Run profile as RUN=STAR <b>16 CoNt</b> Run Profile as RUN=CONT <b>17 PV:</b> Run Profile as RUN=PV <b>18 HoLd:</b> Run Profile as RUN=HOLD <b>19 StoP:</b> Run Profile as RUN=STOP <b>20 d.R.SP:</b> Disable Remote Setpoint	0	R/W	0	65535
144	E4FN	Event input 4 function	<b>1 SP5:</b> SP5 activated to replace SP1 <b>Others:</b> Same as E3FN	0	R/W	0	65535
145	E5FN	Event input 5 function	<b>0 NoNE:</b> none <b>1 SP6:</b> SP6 activated to replace SP1 <b>2 rS.A1:</b> Reset alarm 1 output <b>3 rS.A2:</b> Reset alarm 2 output <b>4 rS.A3:</b> Reset alarm 3 output <b>5 rS.A4:</b> Reset alarm 4 output <b>6 rS.Ao:</b> Reset all alarm outputs <b>7 CA.LH:</b> Cancel alarm latch <b>8 d.o1:</b> Disable output 1 <b>9 d.o2:</b> Disable output 2 <b>10 d.o12:</b> Disable output 1& 2 <b>11 LoCK:</b> Lock all parameters and Read-only communication <b>12 AU.MA:</b> Switch Auto and Manual control mode <b>13 F.tra:</b> Failure Transfer <b>20 d.R.SP:</b> Disable Remote Setpoint.	0	R/W	0	65535
146	E6FN	Event input 6 function	<b>1 SP7:</b> SP7 activated to replace SP1 <b>Others:</b> Same as E5FN	0	R/W	0	65535

Modbus Register Address	Parameter Notation	Parameter Description	Range	Default Value	Data Access Type	Scale (Unsigned 16 Bit Data)	
						Low	High
147	A1DL	Alarm 1 Delay (Minutes: Seconds)	OFF: OFF ON: Low: 00.01 High:99.59	00.00	R/W	0	65535
148	A2DL	Alarm 2 Delay (Minutes: Seconds)	OFF: OFF ON: Low: 00.01 High:99.59	00.00	R/W	0	65535
149	A3DL	Alarm 3 Delay (Minutes: Seconds)	OFF: OFF ON: Low: 00.01 High:99.59	00.00	R/W	0	65535
150	A4DL	Alarm 4 Delay (Minutes: Seconds)	OFF: OFF ON: Low: 00.01 High:99.59	00.00	R/W	0	65535
151	SFT	Soft Start Time (Hours: Minutes)	Low: 00.00(OFF) High:99.59	00.00	R/W	0	65535
152	SFL1	Soft Start Power Limit for Output 1	Low: PL1L High: PL1H	0	R/W	0	65535
153	SFL2	Soft Start Power Limit for Output 2	Low: PL2L High: PL2H	0	R/W	0	65535
154	SFTH	Soft Start Threshold	Low: -19999 High:45536	100.0 °C (212.0 °F)	R/W	-19999	45536
155	SFTR	Soft Start Timer (Hours: Minutes)	Low: 00.00 High:99.59	00.00	R	0	65535
156	...	Reserved	...	...	...	...	...
157	...	Reserved	...	...	...	...	...
158	...	Reserved	...	...	...	...	...
159	...	Reserved	...	...	...	...	...
160	...	Reserved	...	...	...	...	...
161	PROF	Profile selection	<b>0 NONE:</b> Not uses. <b>1 1--4:</b> Uses steps 1 to 4 <b>2 5--8:</b> Uses steps 5 to 8 <b>3 1--8:</b> Uses steps 1 to 8 <b>4 9-12:</b> Uses steps 9 to 12 <b>5 1316:</b> Uses steps 13 to 16 <b>6 9-16:</b> Uses steps 9 to 16 <b>7 1-16:</b> Uses steps 1 to 16	0	R/W	0	65535
162	RUN	Profile run control	<b>0 StAR:</b> Start to run profile <b>1 CoNt:</b> Continue run profile <b>2 PV:</b> Continue run profile from current PV <b>3 Hold:</b> Hold profile <b>4 SToP:</b> Stop profile	0	R/W	0	65535
163	RMPU	Unit for Ramp/soak time	<b>0 HH.MM:</b> Hours. Minutes <b>1 MM.SS:</b> Minutes. Seconds	0	R/W	0	65535
164	STAR	Setpoint value at the start of each profile	<b>0 PV:</b> Current process value PV <b>1 SP1:</b> Controller set point value SP1	0	R/W	0	65535

Modbus Register Address	Parameter Notation	Parameter Description	Range	Default Value	Data Access Type	Scale (Unsigned 16 Bit Data)	
						Low	High
165	END	Setpoint value at the end of each profile	<b>0 SP1:</b> Controller set point value SP1	0	R/W	0	65535
166	PFR	Power fail recovery	<b>0 CoNt:</b> Continue profile from the last setpoint value <b>1 PV:</b> Start to run from PV <b>2 SP1:</b> Static mode, SP1	2	R/W	0	65535
167	HBLO	Holdback low band	Low: 0.1°C High: 500.0°C(900.0°F) 0.0 = No low band: NoNE	0.0	R/W	0	65535
168	HBHI	Holdback high band	Low: 0.1°C High: 500.0°C(900.0°F) 0.0 =No high band: NoNE	0.0	R/W	0	65535
169	HBT	Holdback time	Low: 00.00 (Hour. Minute) High: 99.59 (Hour. Minute)	00.00	R/W	0	65535
170	CYCL	Repeat number of cycles for the profile	Low: 1 High: 9999 10000 = inFi: Infinite	1	R/W	0	65535
171	CYCR	Cycle remaining for the profile	Low: 1 High: 9999 10000 = inFi: Infinite	1	R	0	65535
172	STEP	Steps of profile running	<b>Bit 0:</b> Ramp/Soak <b>Bit 1~5:</b> steps from 1 to 16	0	R/W	0	65535
173	TIMR	Time remaining for the current segment	Low: 00.00 High: 99.59	00.00	R/W	0	65535
174	STAT	State of profile running	<b>Bit 0:</b> Profile standby, ready to run profile <b>Bit 1:</b> Profile running <b>Bit 2:</b> Profile holding <b>Bit 3:</b> Profile end <b>Bit 4:</b> Profile holdback <b>Bit 5:</b> Ramp up <b>Bit 6:</b> Ramp down <b>Bit 7:</b> Soak	1	R	0	65535
175	TSP1	Target setpoint for segment 1	Low: SP1L High: SP1H	100.0°C (212.0°F)	R/W	-19999	45536
176	RPT1	Ramp time of segment 1	Low: 00.00 High: 99.59	00.00	R/W	0	65535
177	SKT1	Soak time of segment 1	Low: 00.00 High: 99.59	00.00	R/W	0	65535
178	TSP2	Target setpoint for segment 2	Low: SP1L High: SP1H	100.0°C (212.0°F)	R/W	-19999	45536
179	RPT2	Ramp time of segment 2	Low: 00.00 High: 99.59	00.00	R/W	0	65535
180	SKT2	Soak time of segment 2	Low: 00.00 High: 99.59	00.00	R/W	0	65535
181	TSP3	Target setpoint for segment 3	Low: SP1L High: SP1H	100.0°C (212.0°F)	R/W	-19999	45536
182	RPT3	Ramp time of segment 3	Low: 00.00 High: 99.59	00.00	R/W	0	65535

Modbus Register Address	Parameter Notation	Parameter Description	Range	Default Value	Data Access Type	Scale (Unsigned 16 Bit Data)	
						Low	High
183	SKT3	Soak time of segment 3	Low: 00.00 High: 99.59	00.00	R/W	0	65535
184	TSP4	Target setpoint for segment 4	Low: SP1L High: SP1H	100.0°C (212.0°F)	R/W	-19999	45536
185	RPT4	Ramp time of segment 4	Low: 00.00 High: 99.59	00.00	R/W	0	65535
186	SKT4	Soak time of segment 4	Low: 00.00 High: 99.59	00.00	R/W	0	65535
187	TSP5	Target setpoint for segment 5	Low: SP1L High: SP1H	100.0°C (212.0°F)	R/W	-19999	45536
188	RPT5	Ramp time of segment 5	Low: 00.00 High: 99.59	00.00	R/W	0	65535
189	SKT5	Soak time of segment 5	Low: 00.00 High: 99.59	00.00	R/W	0	65535
190	TSP6	Target setpoint for segment 6	Low: SP1L High: SP1H	100.0°C (212.0°F)	R/W	-19999	45536
191	RPT6	Ramp time of segment 6	Low: 00.00 High: 99.59	00.00	R/W	0	65535
192	SKT6	Soak time of segment 6	Low: 00.00 High: 99.59	00.00	R/W	0	65535
193	TSP7	Target setpoint for segment 7	Low: SP1L High: SP1H	100.0°C (212.0°F)	R/W	-19999	45536
194	RPT7	Ramp time of segment 7	Low: 00.00 High: 99.59	00.00	R/W	0	65535
195	SKT7	Soak time of segment 7	Low: 00.00 High: 99.59	00.00	R/W	0	65535
196	TSP8	Target setpoint for segment 8	Low: SP1L High: SP1H	100.0°C (212.0°F)	R/W	-19999	45536
197	RPT8	Ramp time of segment 8	Low: 00.00 High: 99.59	00.00	R/W	0	65535
198	SKT8	Soak time of segment 8	Low: 00.00 High: 99.59	00.00	R/W	0	65535
199	TSP9	Target setpoint for segment 9	Low: SP1L High: SP1H	100.0°C (212.0°F)	R/W	-19999	45536
200	RPT9	Ramp time of segment 9	Low: 00.00 High: 99.59	00.00	R/W	0	65535
201	SKT9	Soak time of segment 9	Low: 00.00 High: 99.59	00.00	R/W	0	65535
202	TSPA	Target setpoint for segment 10	Low: SP1L High: SP1H	100.0°C (212.0°F)	R/W	-19999	45536
203	RPTA	Ramp time of segment 10	Low: 00.00 High: 99.59	00.00	R/W	0	65535
204	SKTA	Soak time of segment 10	Low: 00.00 High: 99.59	00.00	R/W	0	65535
205	TSPB	Target setpoint for segment 11	Low: SP1L High: SP1H	100.0°C (212.0°F)	R/W	-19999	45536
206	RPTB	Ramp time of segment 11	Low: 00.00 High: 99.59	00.00	R/W	0	65535
207	SKTB	Soak time of segment 11	Low: 00.00 High: 99.59	00.00	R/W	0	65535
208	TSPC	Target setpoint for segment 12	Low: SP1L High: SP1H	100.0°C (212.0°F)	R/W	-19999	45536

Modbus Register Address	Parameter Notation	Parameter Description	Range	Default Value	Data Access Type	Scale (Unsigned 16 Bit Data)	
						Low	High
209	RPTC	Ramp time of segment 12	Low: 00.00 High: 99.59	00.00	R/W	0	65535
210	SKTC	Soak time of segment 12	Low: 00.00 High: 99.59	00.00	R/W	0	65535
211	TSPD	Target setpoint for segment 13	Low: SP1L High: SP1H	100.0°C (212.0°F)	R/W	-19999	45536
212	RPTD	Ramp time of segment 13	Low: 00.00 High: 99.59	00.00	R/W	0	65535
213	SKTD	Soak time of segment 13	Low: 00.00 High: 99.59	00.00	R/W	0	65535
214	TSPE	Target setpoint for segment 14	Low: SP1L High: SP1H	100.0°C (212.0°F)	R/W	-19999	45536
215	RPTE	Ramp time of segment 14	Low: 00.00 High: 99.59	00.00	R/W	0	65535
216	SKTE	Soak time of segment 14	Low: 00.00 High: 99.59	00.00	R/W	0	65535
217	TSPF	Target setpoint for segment 15	Low: SP1L High: SP1H	100.0°C (212.0°F)	R/W	-19999	45536
218	RPTF	Ramp time of segment 15	Low: 00.00 High: 99.59	00.00	R/W	0	65535
219	SKTF	Soak time of segment 15	Low: 00.00 High: 99.59	00.00	R/W	0	65535
220	TSPG	Target setpoint for segment 16	Low: SP1L High: SP1H	100.0°C (212.0°F)	R/W	-19999	45536
221	RPTG	Ramp time of segment 16	Low: 00.00 High: 99.59	00.00	R/W	0	65535
222	SKTG	Soak time of segment 16	Low: 00.00 High: 99.59	00.00	R/W	0	65535

## 2 Installation and Wiring

 Sometimes dangerous voltages capable of causing death are present in this instrument. Before doing the installation or any troubleshooting procedures, the power to the equipment must be switched off and isolated. Units suspected of being faulty must be disconnected and removed to a properly equipped workshop for testing and repair. Component replacement and internal adjustments must be made by a qualified maintenance person only.

 To minimize the possibility of fire or shock hazards, do not expose this instrument to rain or excessive moisture.

 Do not use this instrument in areas under hazardous conditions such as excessive shock, vibration, dirt, moisture, corrosive gases or oil. The ambient temperature of the area should not exceed the maximum rating specified in the specification

 Remove stains from this equipment using a soft, dry cloth. Do not use harsh chemicals, volatile solvents such as thinner or strong detergents to clean the equipment to avoid deformation.

 If the equipment is used in a manner not specified by the manufacturer, the protection provided by the equipment may be impaired.

### 2.1 Unpacking

Upon receipt of the shipment, remove the controller from the carton and inspect the unit for shipping damage. If any damage is found, contact your local representative immediately. Note the model number and serial number for future reference when corresponding with our service center. The serial number (S/N) is labelled on the box and the housing of the controller.

The controller is designed for indoor use only and is not intended for use in any hazardous area. It should be kept away from shock, vibration, and electromagnetic fields (such as variable frequency drives), motors and transformers. It is intended to operate under the following environmental conditions.

Environmental Parameter	Specification
Operating Temperature	-10°C to 50 °C
Humidity	0% to 90% RH(Non-condensing)
Altitude	2000 M Maximum

#### *2-1 Environmental Specification*

### 2.2 Mounting

Make the panel cut out as per the dimensions required by the controller. The dimensions of the different sizes of this series controller series are given in the following section. Remove the mounting clamps from the controller and insert the controller into the panel cut out. After inserting the controller into the panel cut out, re-install the mounting clamps. Gently tighten the clamp screws until the controller is properly secured into the cutout.

#### 2.2.1 C22 Dimension

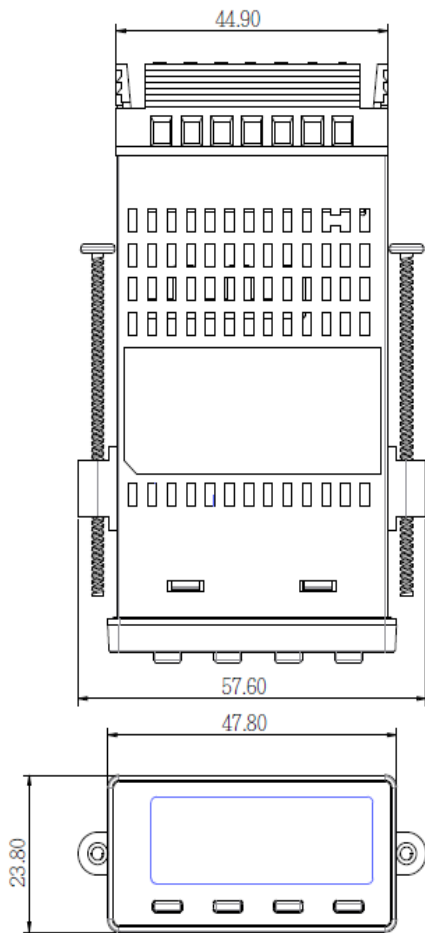

Recommended panel thickness is 1 to 5mm.  
The torque value of the screw lock must be less than 0.7 KGfCM

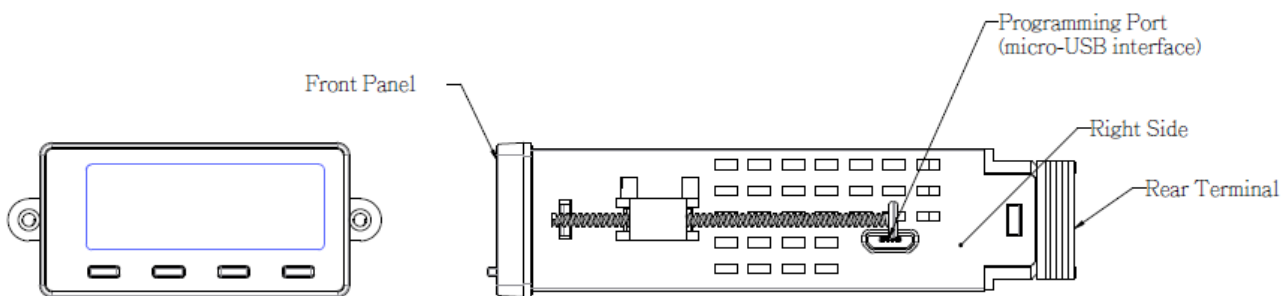
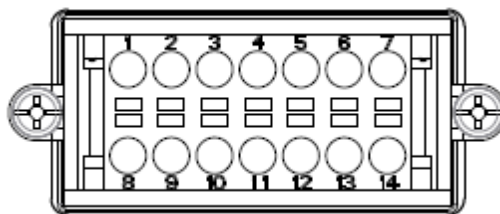
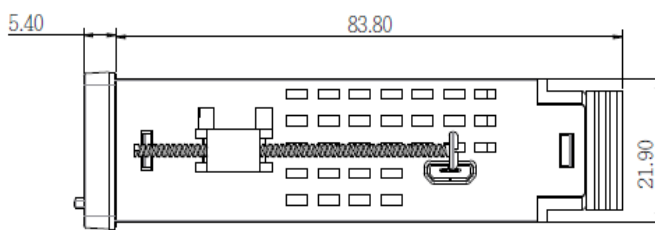
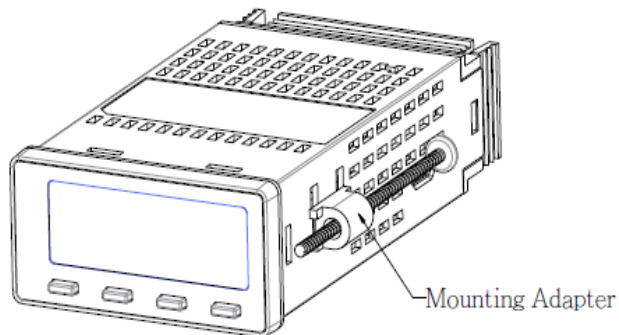

**2-1 C22 Dimensions with clamp**



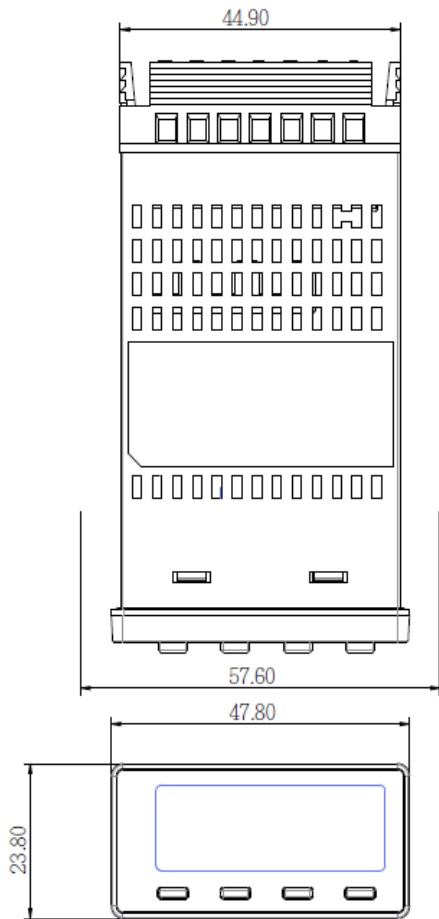

Recommended panel thickness is 1 to 5mm.  
The torque value of the screw lock must be less than 0.7 KGfCM

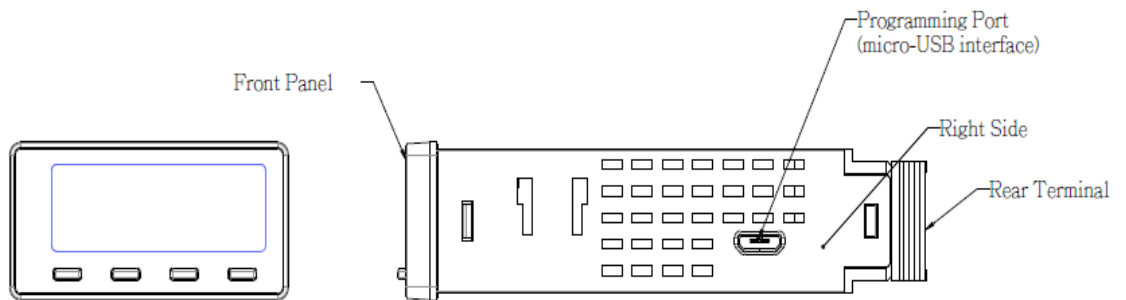
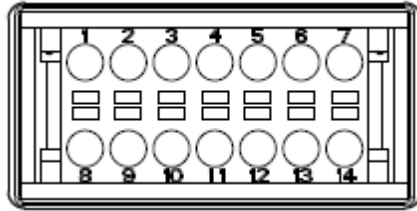
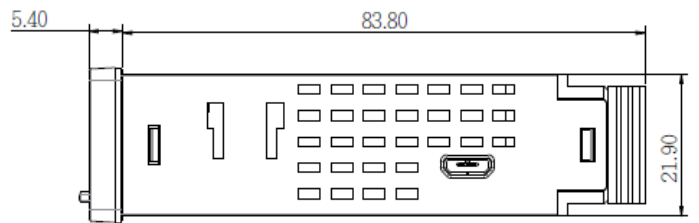
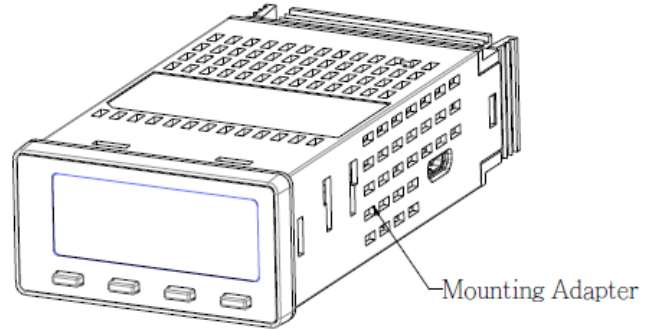

**2-2 C22 Dimension without Clamp**

## 2.2.2 C62 Dimension

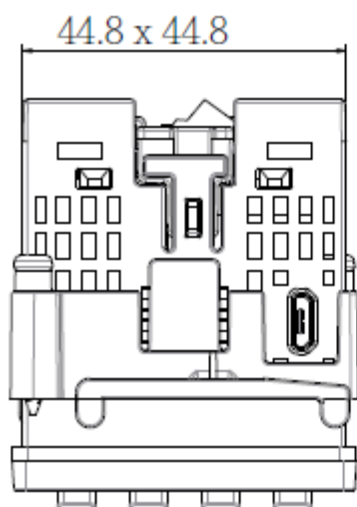

Recommended Panel Thickness is 1 to 5mm

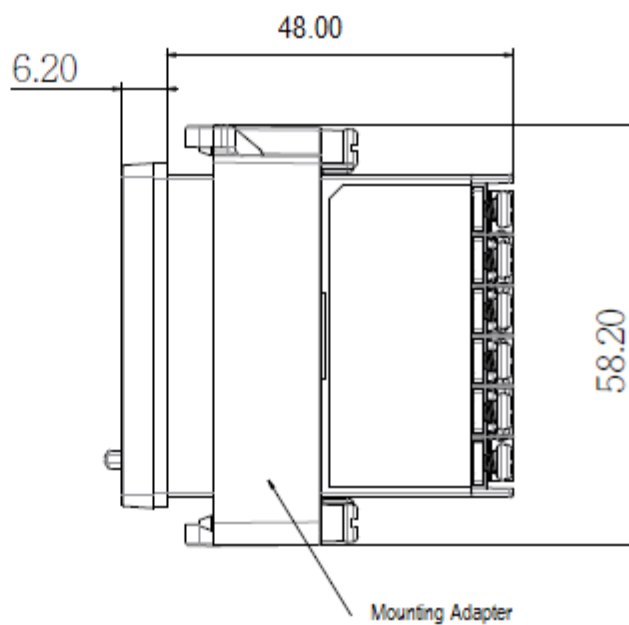

**2-3 C62 Dimension with clamp**

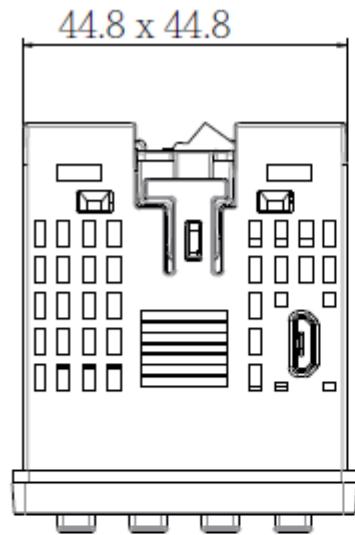

Recommended Panel Thickness is 1 to 5mm

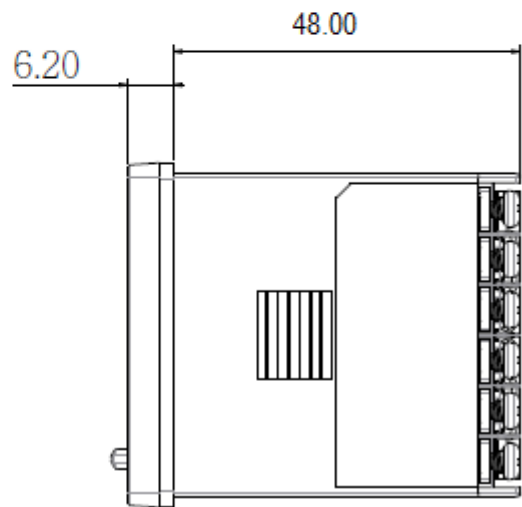
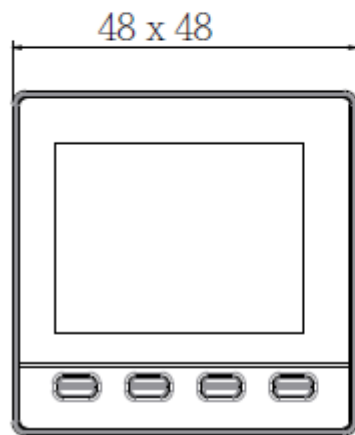

**2-4 C62 Dimension without Clamp**

### 2.2.3 C82 Dimension

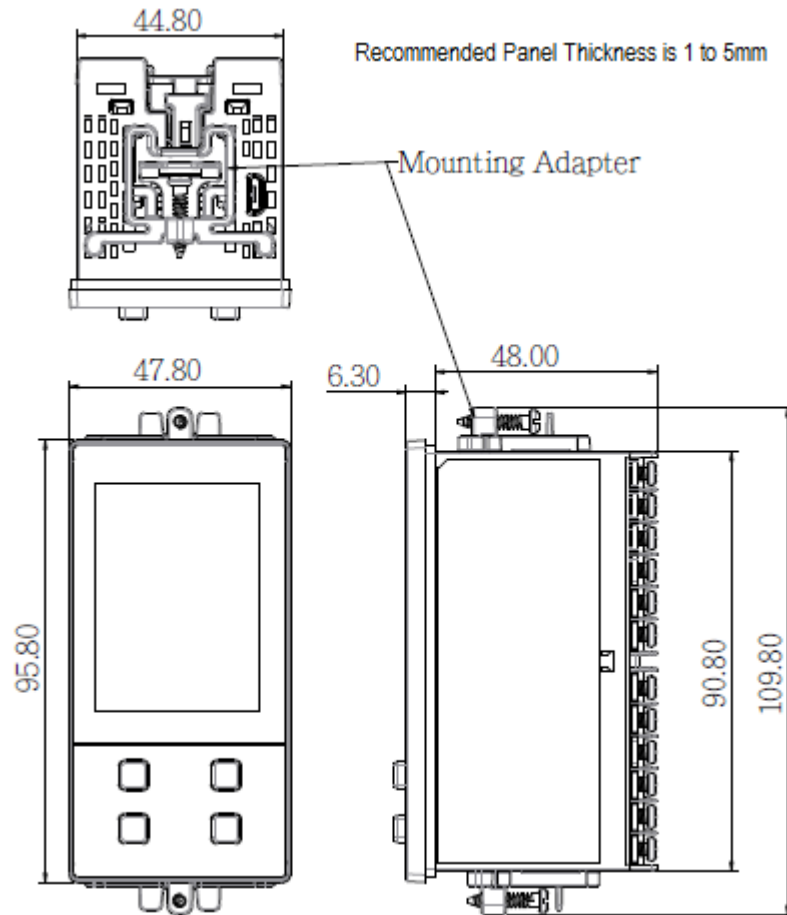

**2-5 C82 Dimension with Clamp**

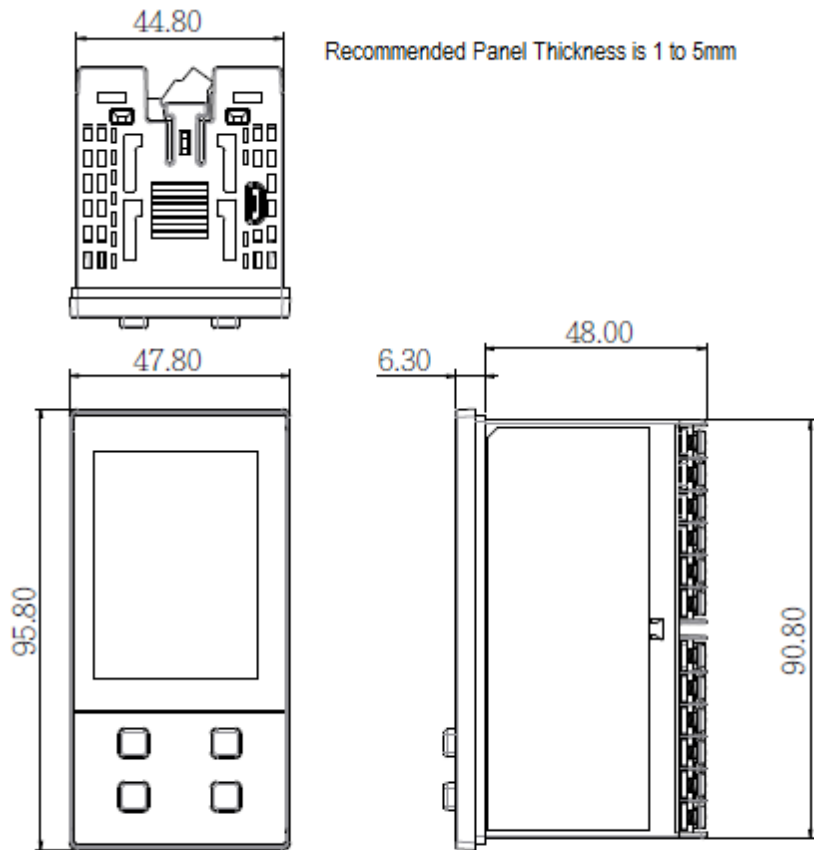

**2-6 C82 Dimension without Clamps**

**2.2.4 C83 Dimension**

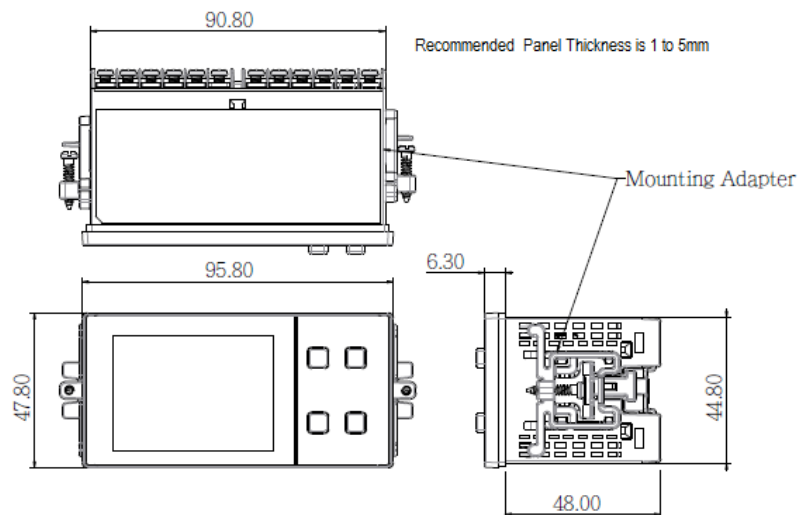

**2-7 C83 Dimension with Clamps**

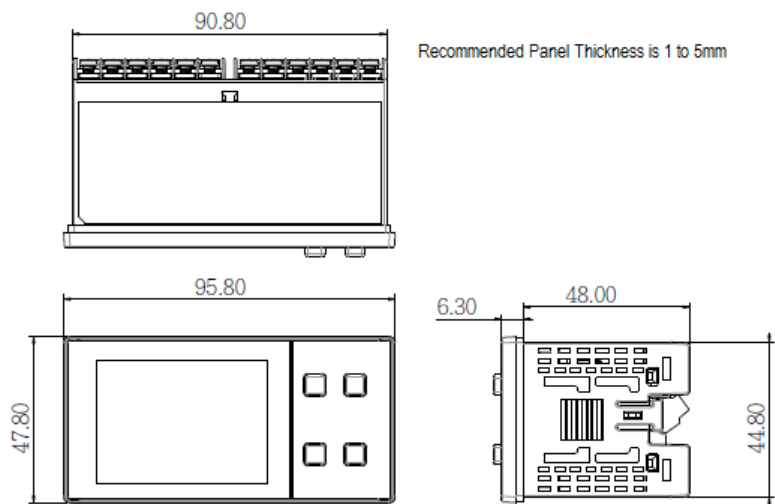

**2-8 C83 Dimension without Clamp**

**2.2.5 C72 Dimension**

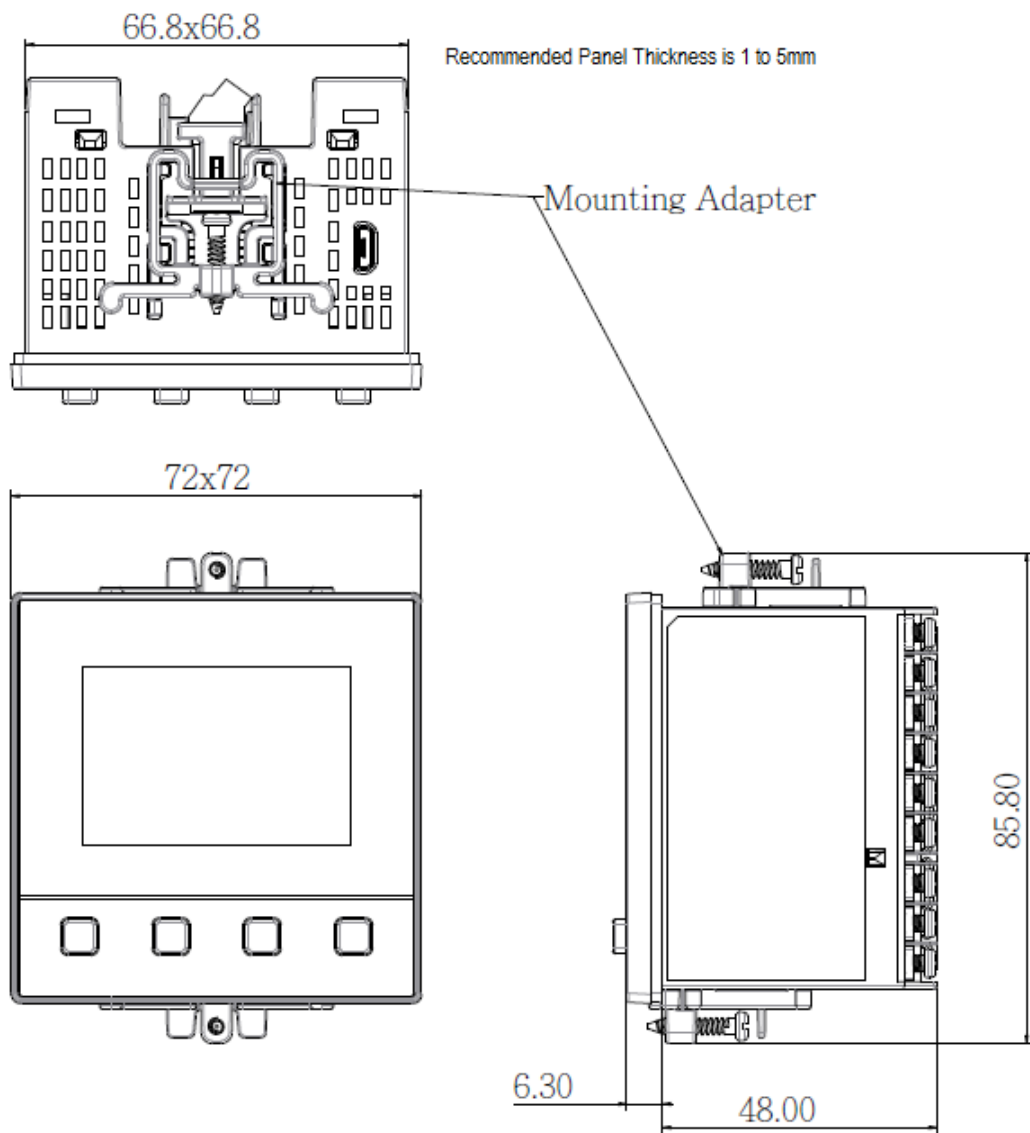

**2-9 C72 Dimension with Clamp**

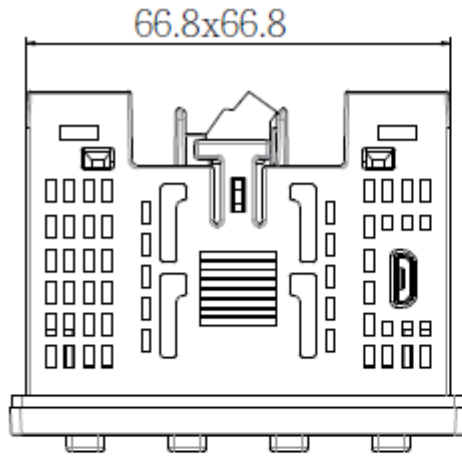

Recommended Panel Thickness is 1 to 5mm

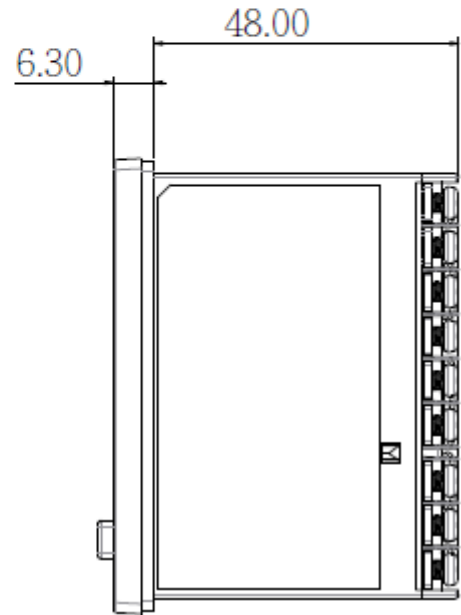
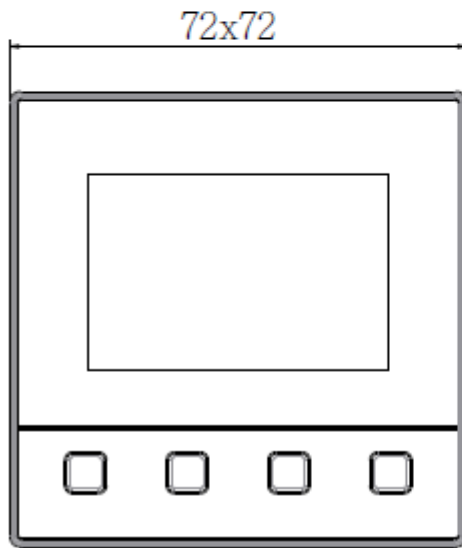

**2-10 C72 Dimension without Clamp**

## 2.2.6 C42 Dimension

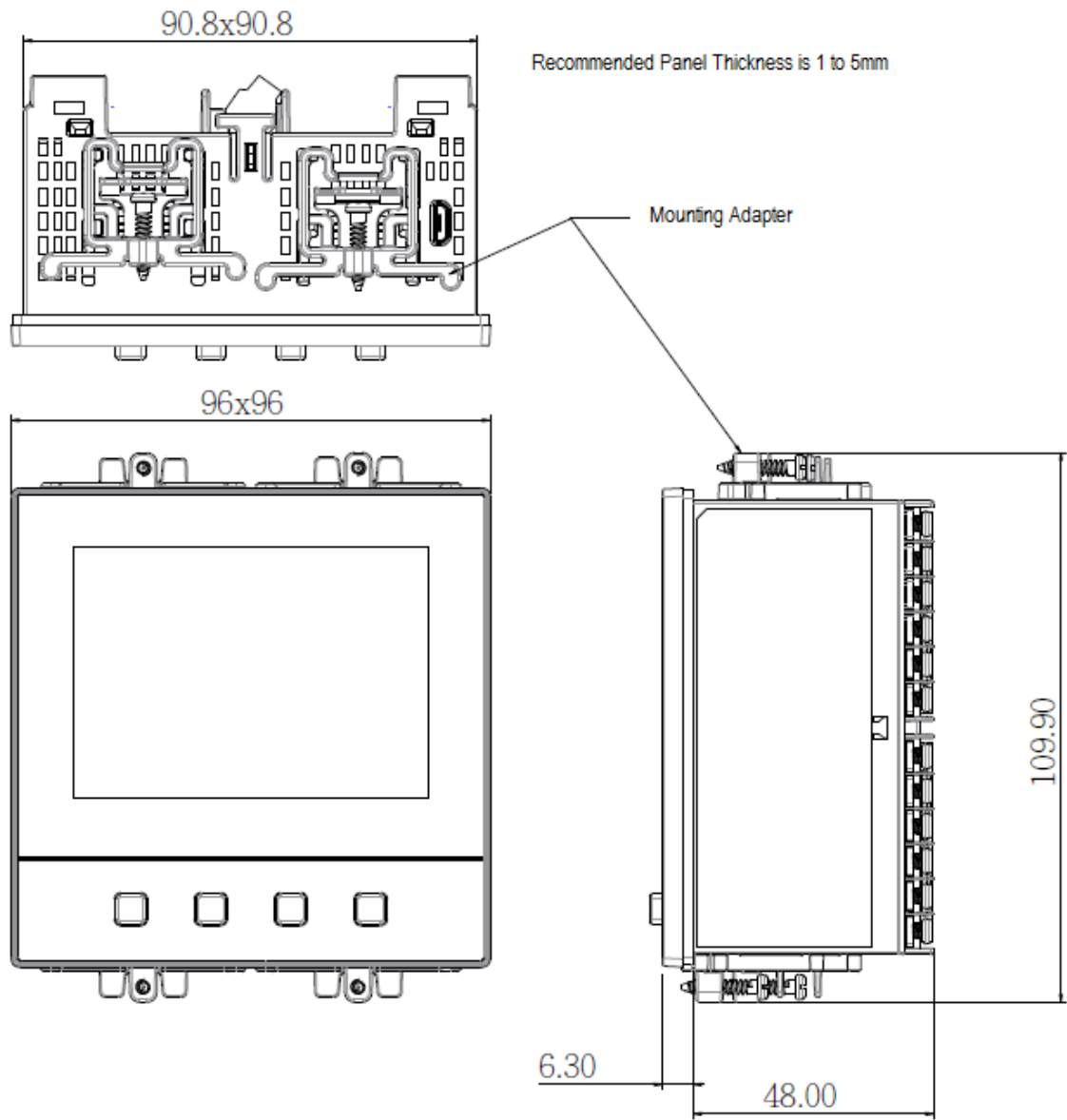

**2-11 C42 Dimension with Clamps**



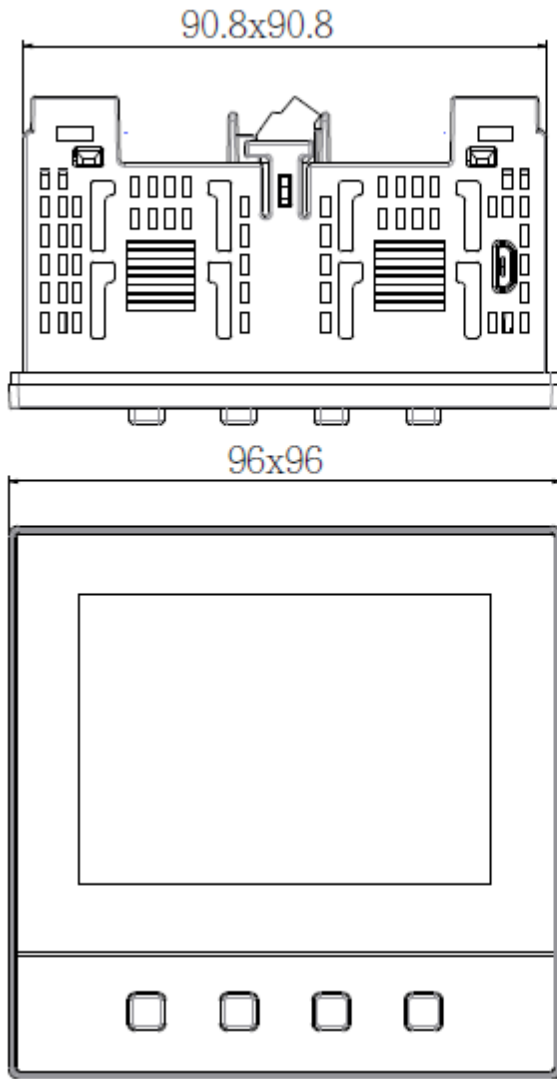

Recommended Panel Thickness is 1 to 5mm

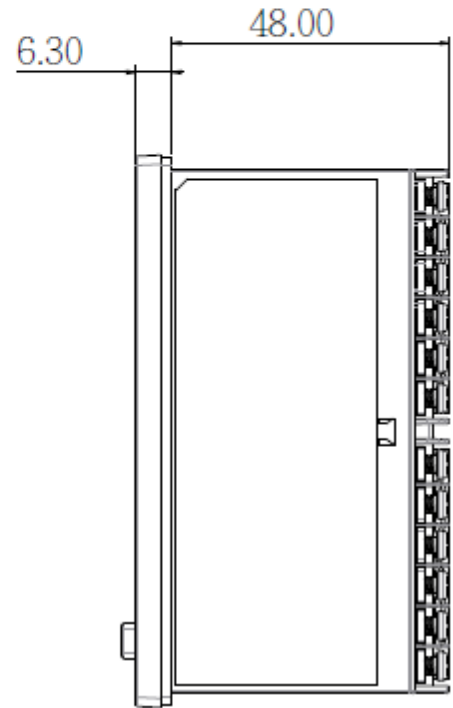

**2-12 C42 Dimension without Clamp**

## 2.2.7 R22 Dimension

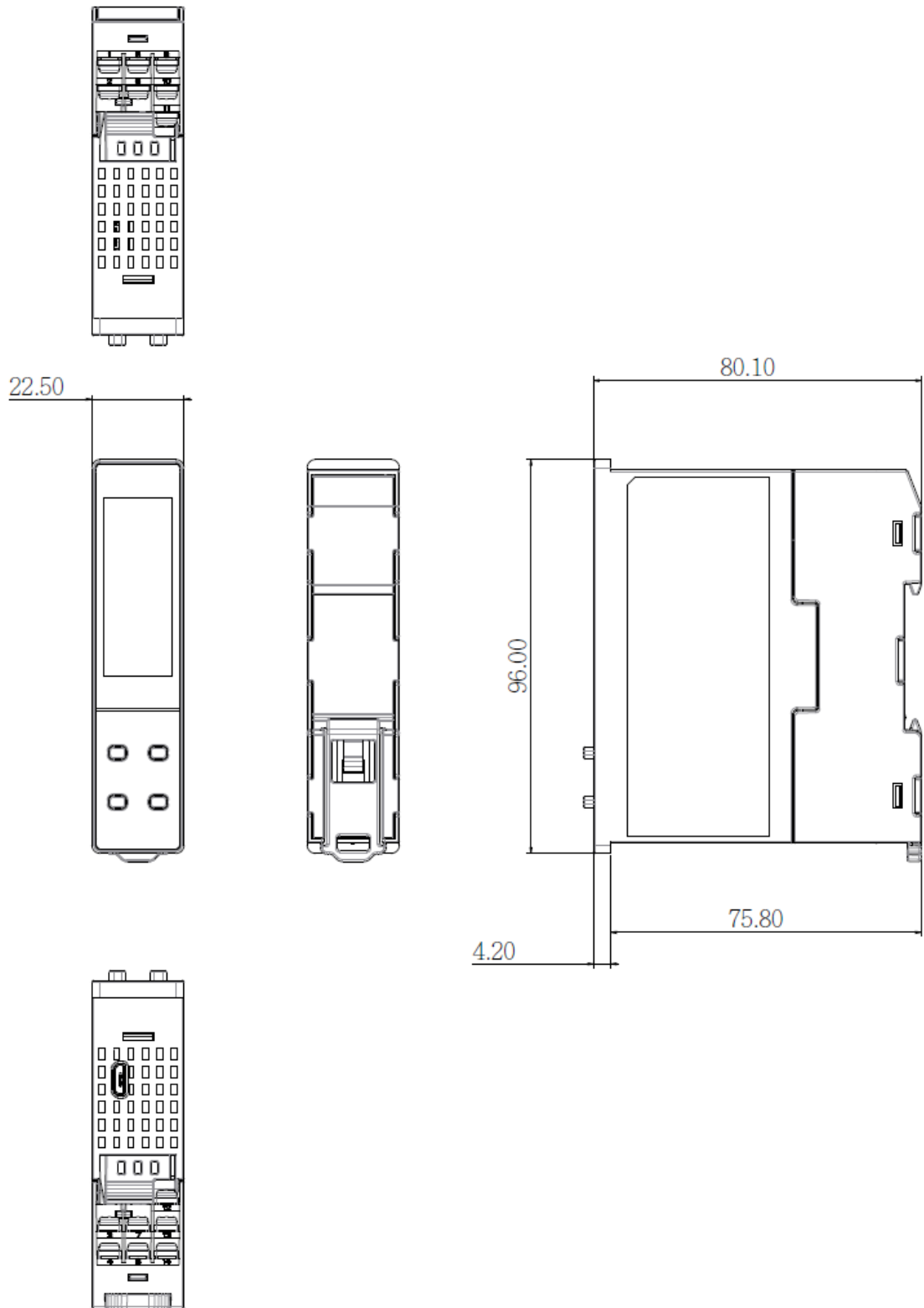

**2-13 R22 Dimension**

## 2.2.8 CT98-1 Dimension

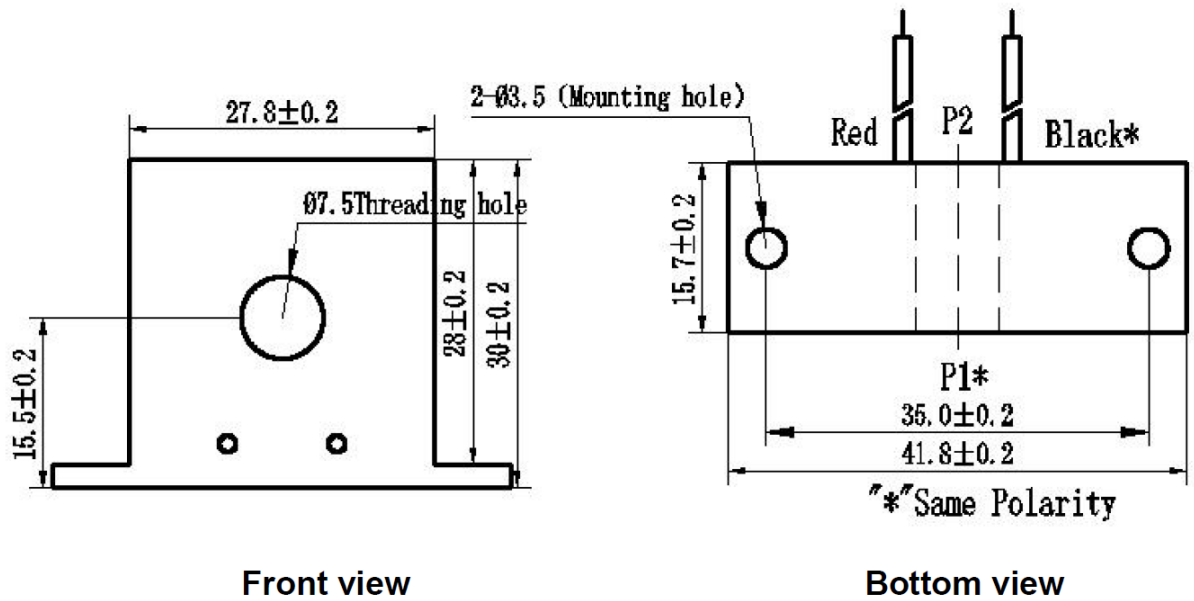

**2-14 CT98-1 Dimension**

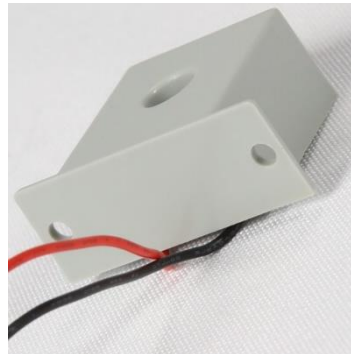

**2-15 CT98-1 Appearance**

## 2.3 Wiring

**!** Sometimes dangerous voltages capable of causing death are present in this instrument. Before doing the installation or any troubleshooting procedures, the power to the equipment must be switched off and isolated. Units suspected of being faulty must be disconnected and removed to a properly equipped workshop for testing and repair. Component replacement and internal adjustments must be made by a qualified maintenance person only.

The utmost care must be taken to ensure that the maximum voltage rating specified on the label is not exceeded.

It is recommended that the supply power of these units be protected by fuses or circuit breakers rated at the lowest value possible

All units should be installed inside a suitably grounded metal enclosure to prevent live parts being accessible to human hands and metal tools.

All wiring must conform to appropriate standards of good practice and local codes and regulations.

Wiring must be suitable for the voltage, current, wire size (18AWG) and temperature rating of the system.

The tightening torque on the Screw terminals; for C22 should not exceed 0.19 N-m (1.74 Lb-in or 2 Kg F-cm) and C62/72/42/82/83 and R22 should not exceed 1 N-m (8.9 Lb-in or 10.2 KgF-cm). temperature Min.60°C, use copper conductors only.

Except Thermocouple Wiring, all other wires used are to be standard copper conductors with the maximum Gauge not exceeding 18AWG. Before powering on the controller, the equipment ground must be connected with a minimum of 1.6mm diameter conductor for protective grounding.

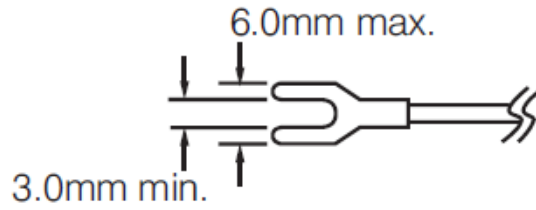

**2-16 Lead Terminal for all models except C22**



**2-17 Lead Terminal for C22**

### 2.3.1 C22 Terminal Connection

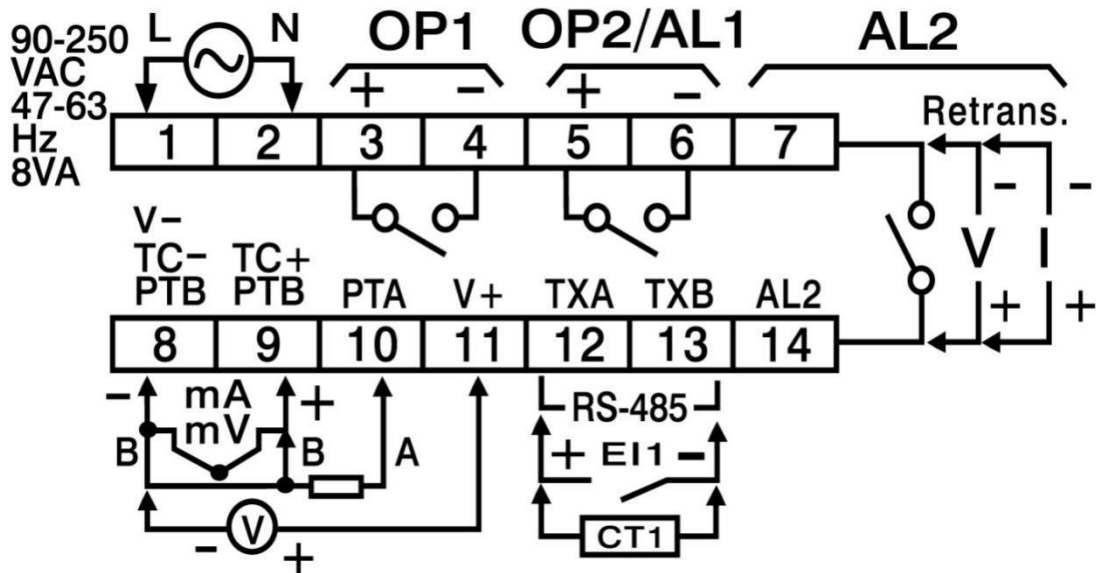

**2-18 C22 Rear Terminal Connection**

### 2.3.2 C62 Terminal Connection

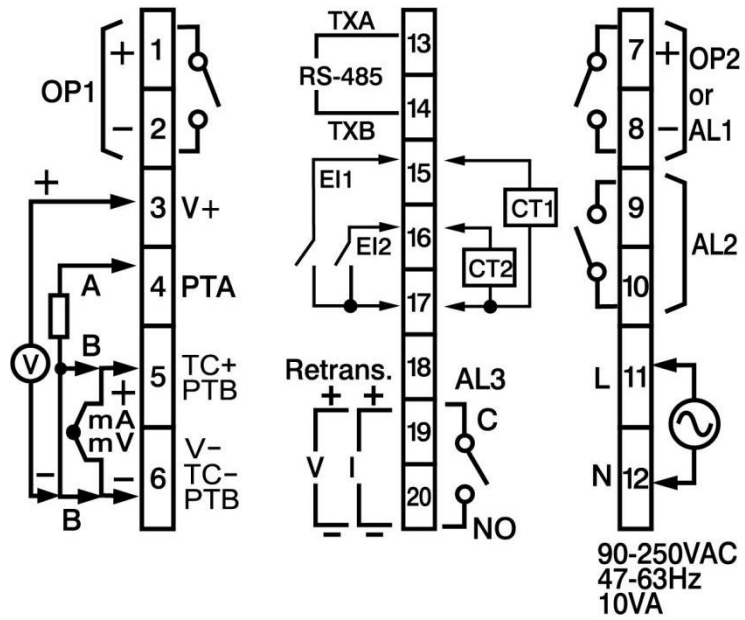

2-19 C62 Rear Terminal Connection

### 2.3.3 C82 & C42 Terminal Connection

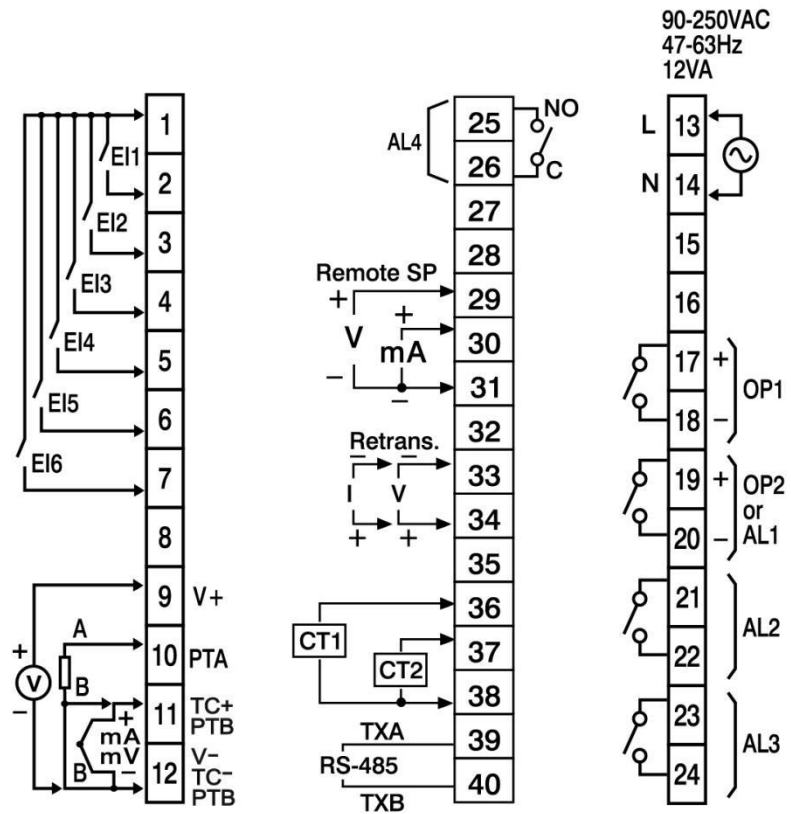

2-20 C82 & C42 Rear Terminal Connection

### 2.3.4 C83 Terminal Connection

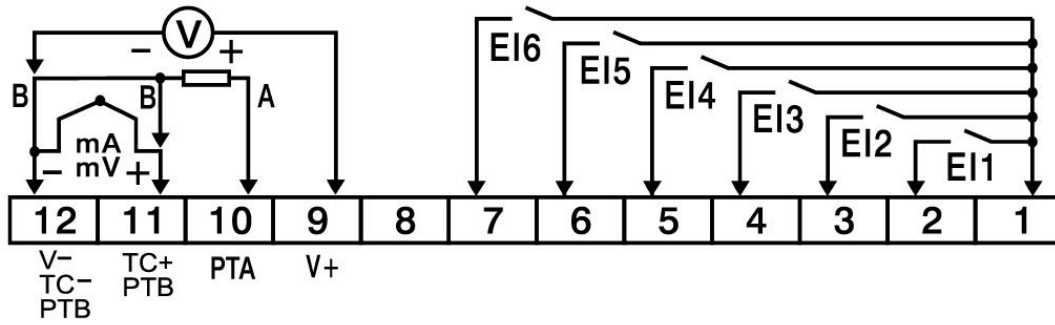
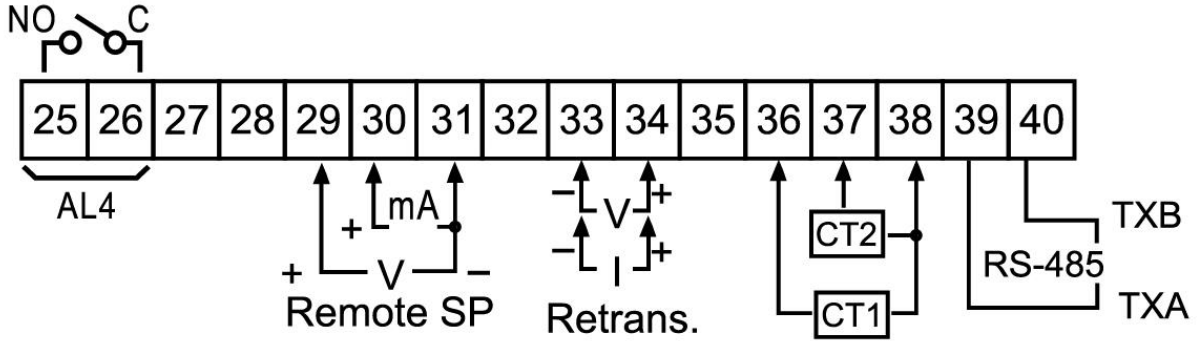
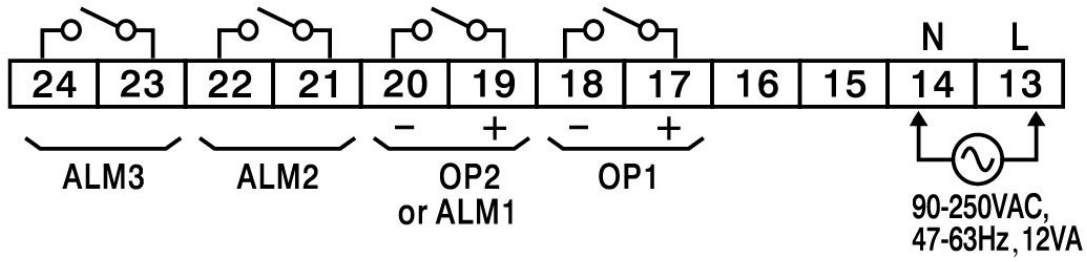

2-21 C83 Rear Terminal Connection

2.3.5 C72 Terminal Connection

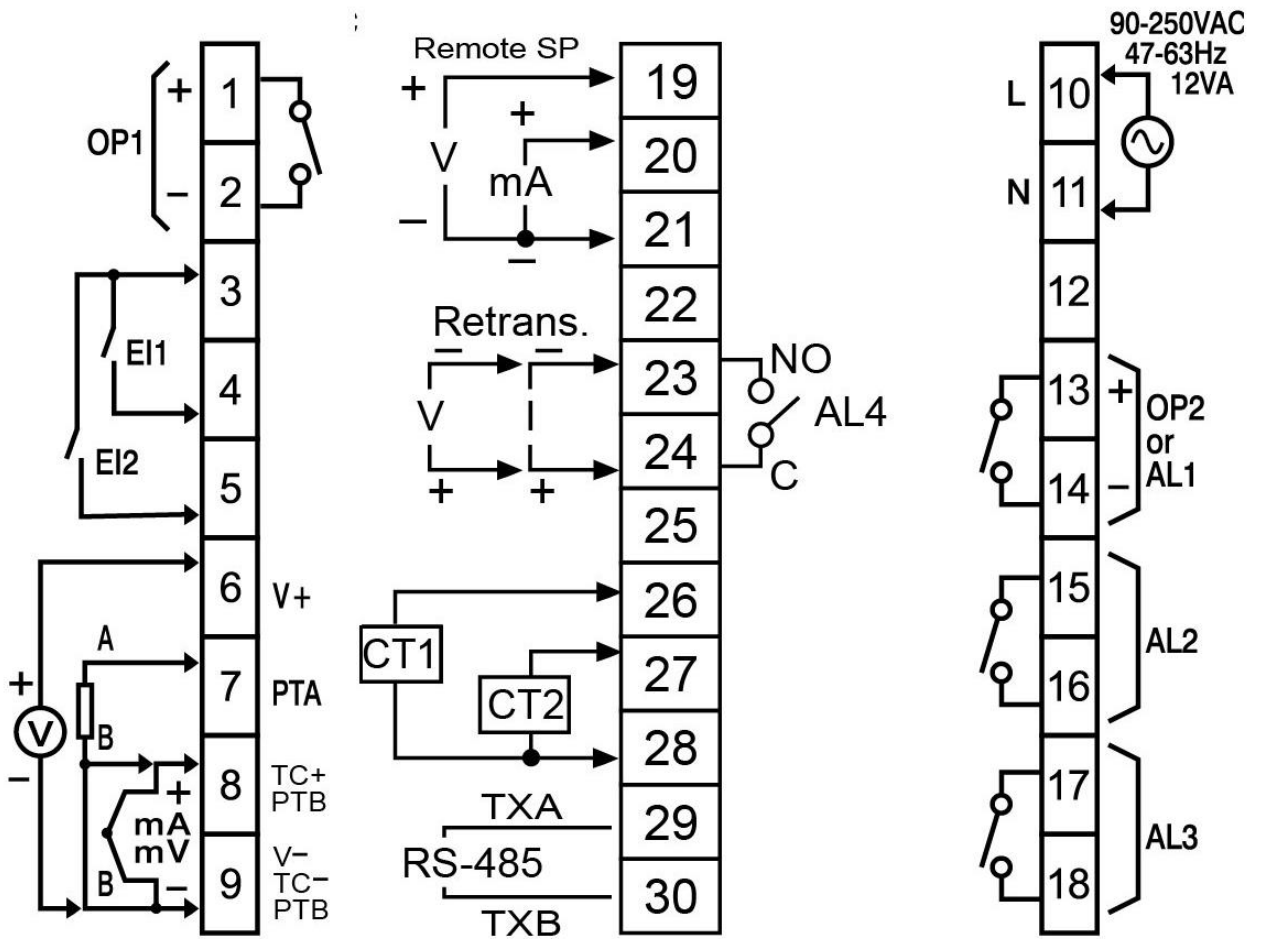

2-22 C72 Rear Terminal Connection



### 2.3.6 R22 Terminal Connection

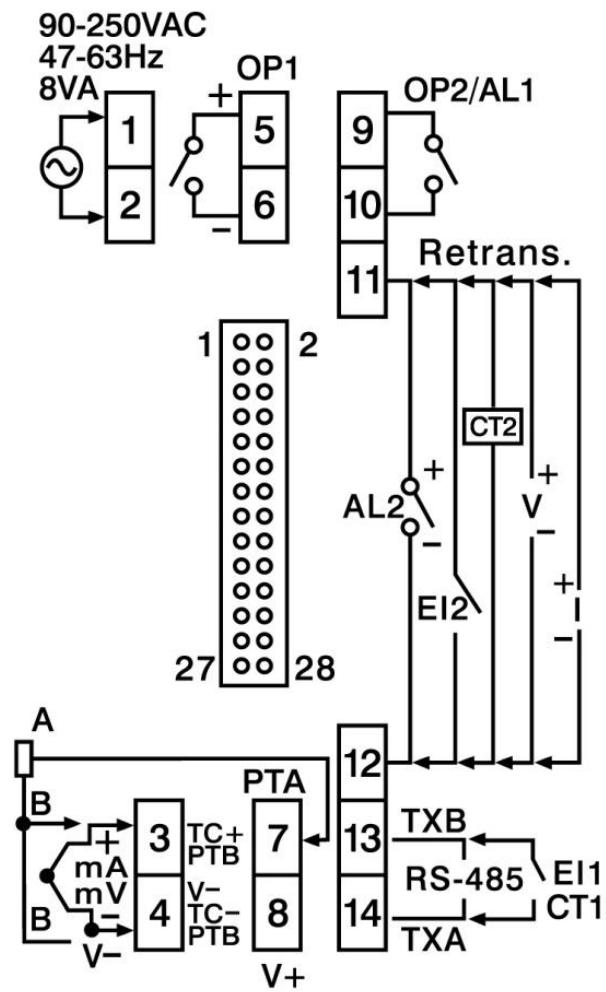

2-23 R22 Terminal Connection

## 2.4 Power Wiring

The controller is designed to operate at either 11-26VAC/VDC or 90-250VAC depending on power input option ordered. Check that the installation voltage corresponds with the power rating indicated on the product label before connecting power to the controller. Near the controller, a fuse and a switch rated at 2A/250VAC should be equipped as shown below.

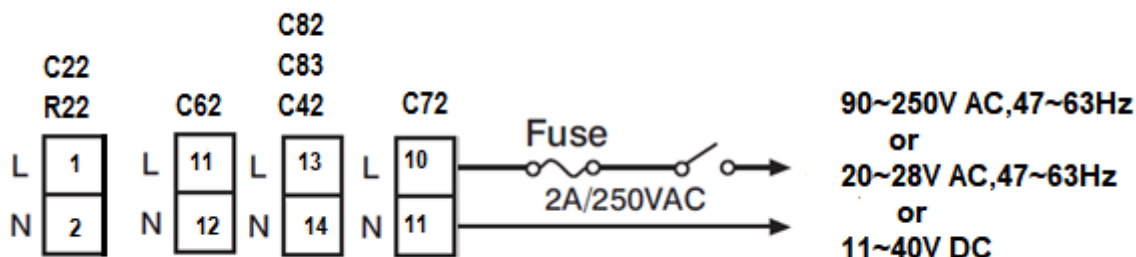

2-24 Power Wiring

**!** This equipment is designed for installation in an enclosure which provides adequate protection against electric shock. The enclosure must be connected to earth ground.

**!** Local requirements regarding electrical installation should be rigidly observed. Consideration should be given to prevent unauthorized persons from accessing the power terminals.

## 2.5 Sensor Installation

Proper sensor installation can eliminate many problems in a control system. The probe should be placed so that it can detect any temperature change with minimal thermal lag. In a process that requires fairly constant heat output, the probe should be placed close to the heater. In a process where the heat demand is variable, the probe should be closed to the work area. Some experiments with probe location are often required to find this optimum position.

In a liquid process, the addition of a stirrer or agitator can help to eliminate thermal lag. Since the thermocouple is a point measuring device, placing more than one thermocouple in parallel can provide average temperature readout and produce better results in most air heated processes.

The proper sensor type is also a very important factor to obtain precise measurements. The sensor must have the correct temperature range to meet the process requirements. In special processes, the sensor might need to have different requirements such as being leak-proof, ant vibration, antiseptic, etc.

Standard sensor limits of error are  $\pm 4^{\circ}\text{F}$  ( $\pm 2^{\circ}\text{C}$ ) or 0.75% of sensed temperature (half that for special) plus drift caused by improper protection or an over-temperature occurrence. This error is far greater than controller error and cannot be corrected on the sensor except by proper selection and replacement.

## 2.6 Sensor Input Wiring

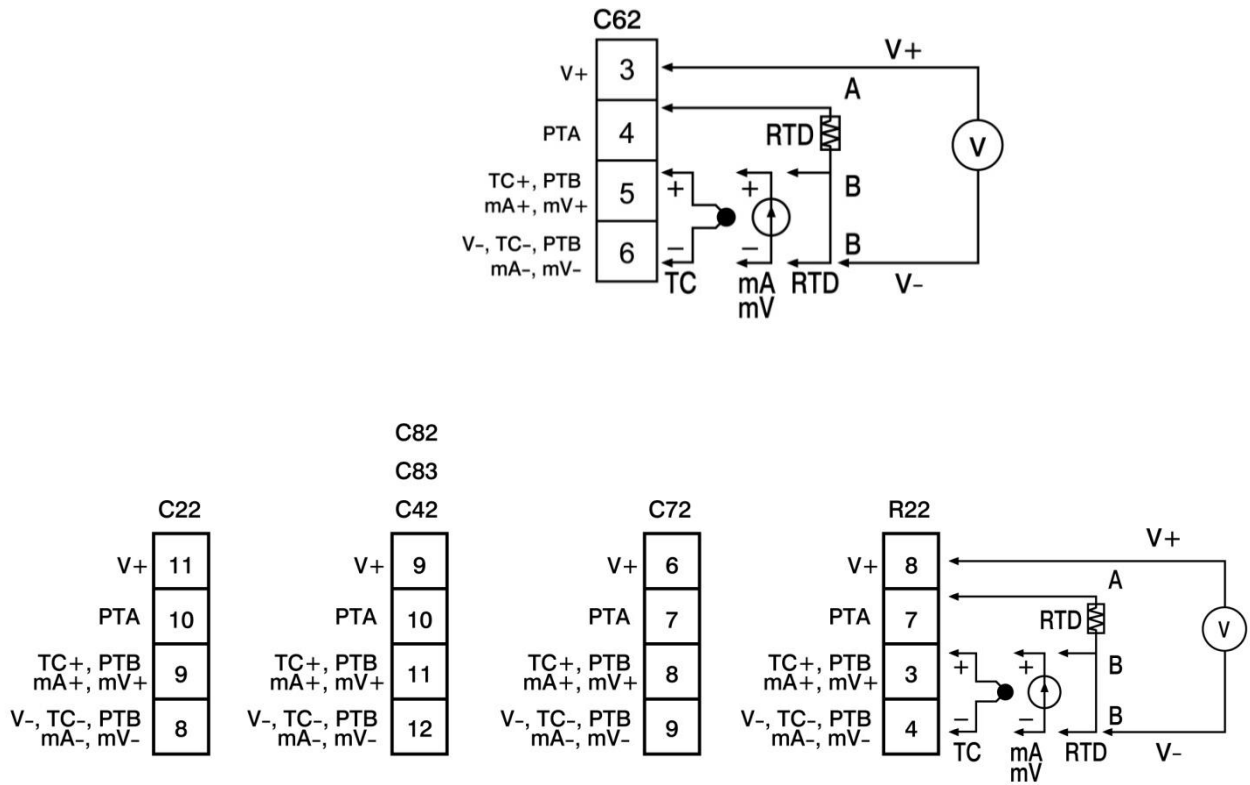

2-25 Sensor Input Wiring

## 2.7 Control Output Wiring

### 2.7.1 Output 1

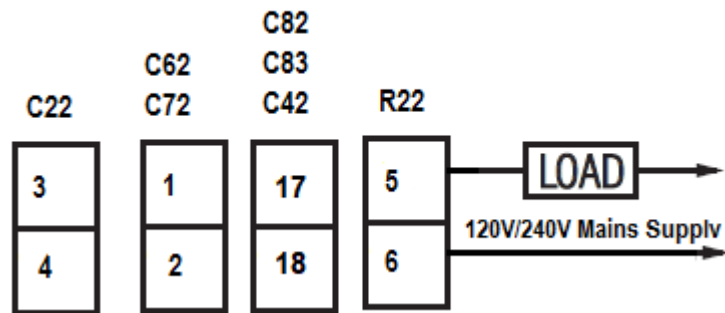

2-26 Output 1 Relay to Drive Load

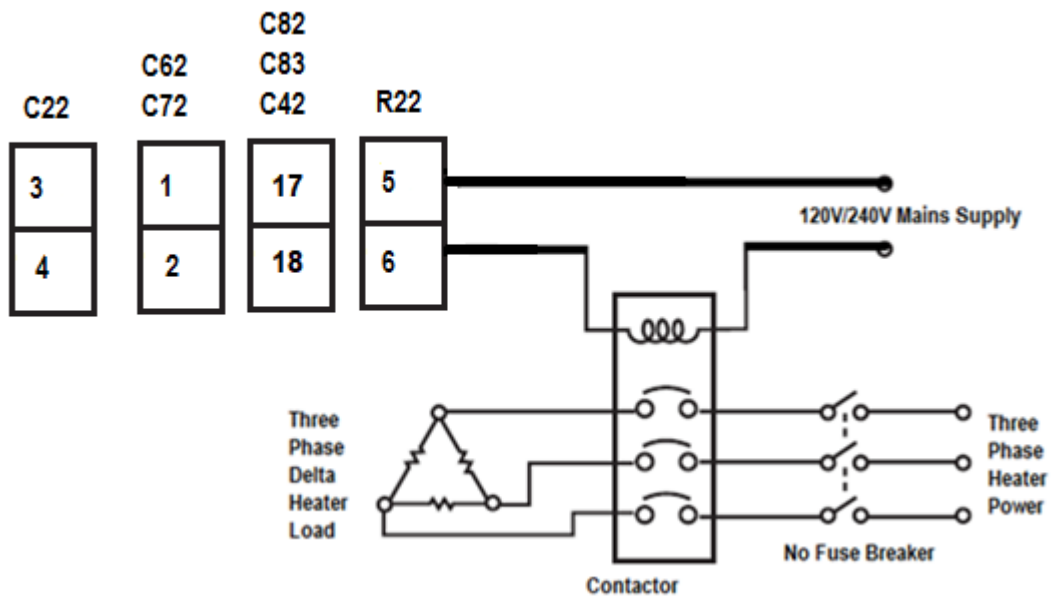

2-27 Output 1 Relay to Drive Contactor

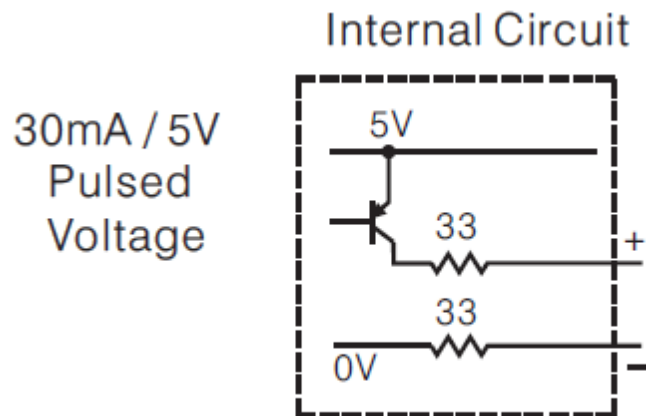
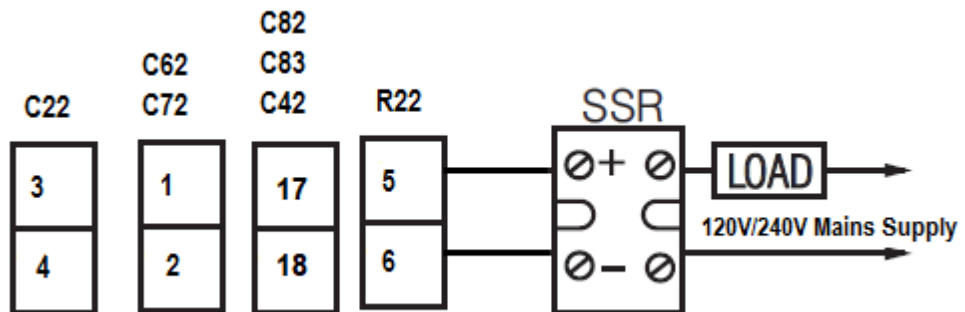

2-28 Output1 Pulsed voltage to Drive SSR

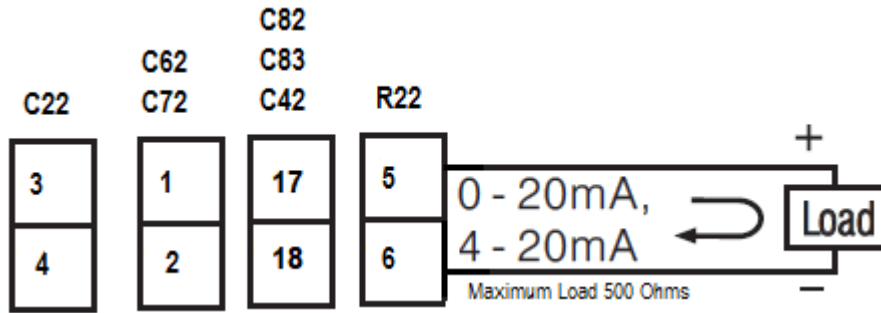

**2-29 Output 1 Linear Current Control**

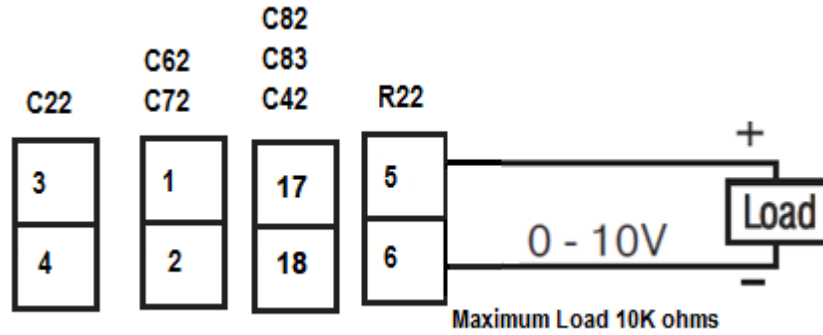

**2-30 Output 1 Linear Voltage Control**

**2.7.2 Output 2**

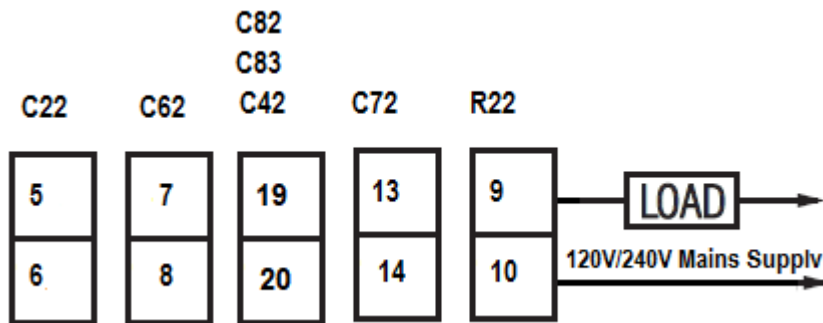

**2-31 Output 2 Relay to Drive Load**

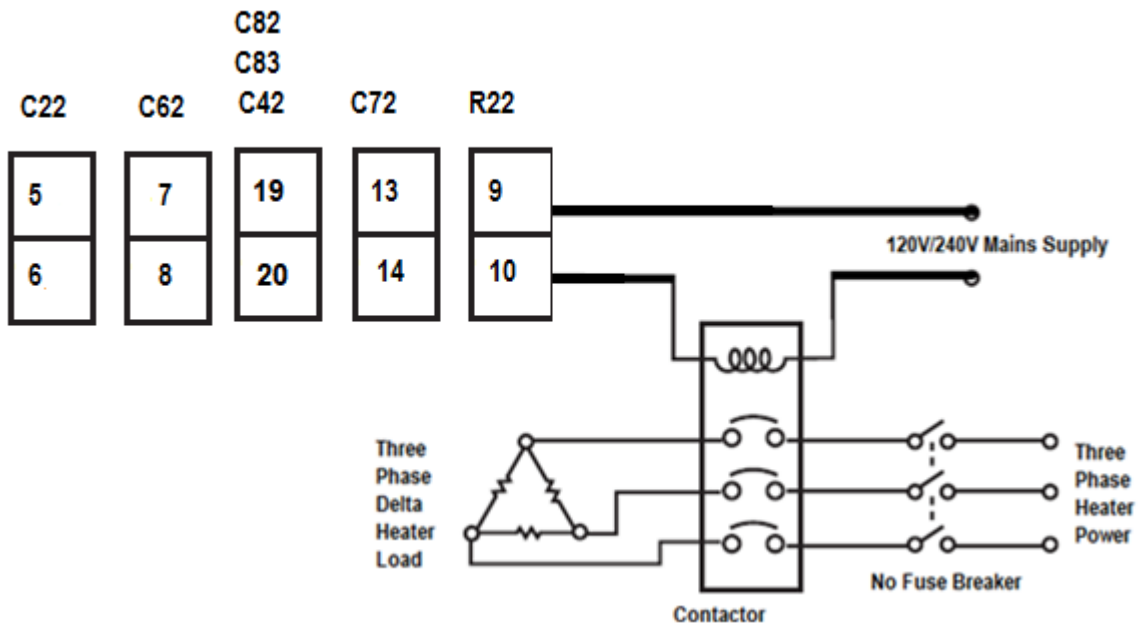

**2-32 Output 2 Relay to Drive Contactor**

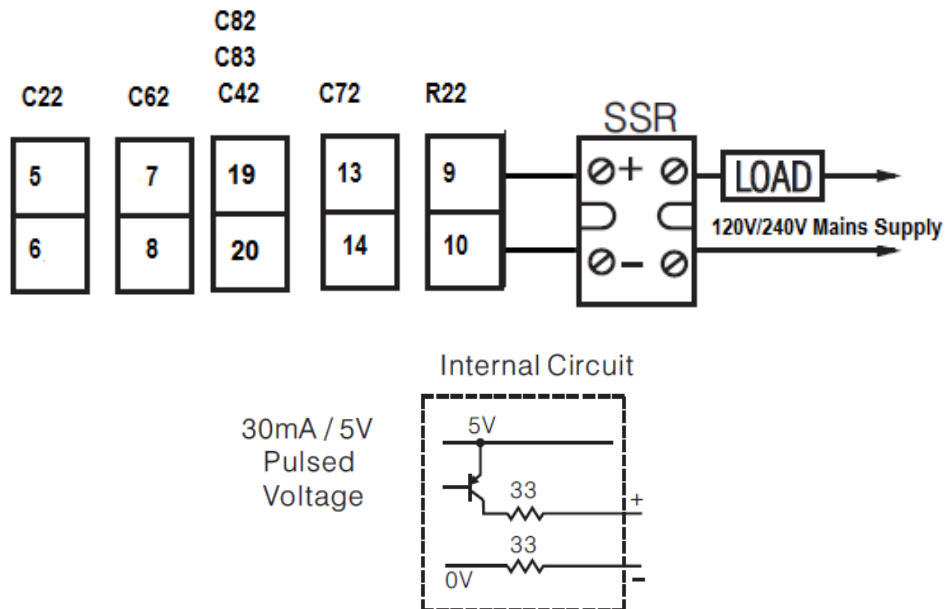

**2-33 Output 2 Pulsed Voltage to Drive SSR**

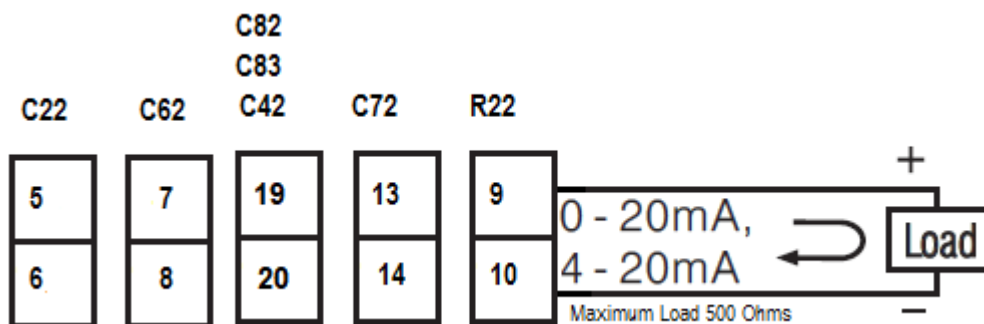

**2-34 Output 2 Linear Current Control**

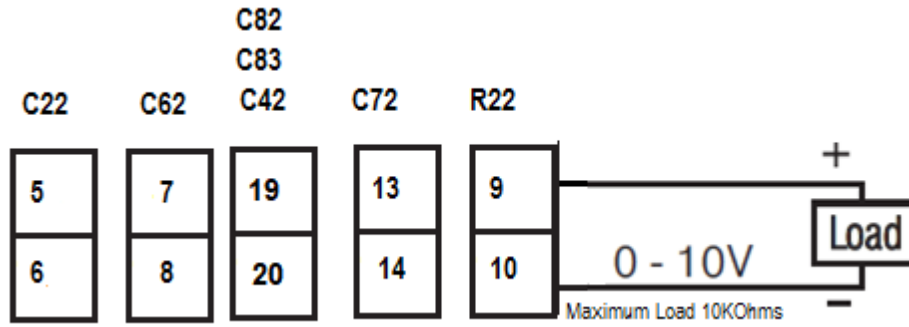

**2-35 Output 2 Linear Voltage Control**

**2.8 Alarm Wiring**

**2.8.1 Alarm 1**

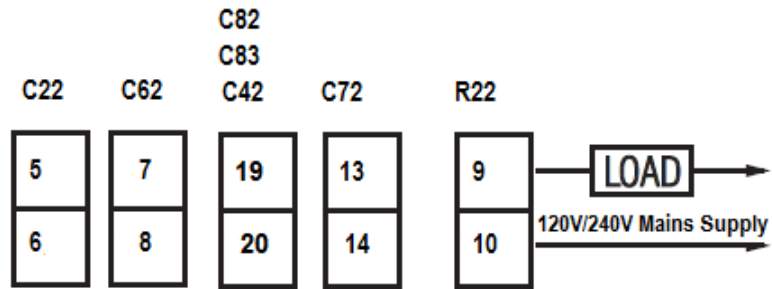

**2-36 Alarm 1 Output to Drive Load**

**2.8.2 Alarm 2**

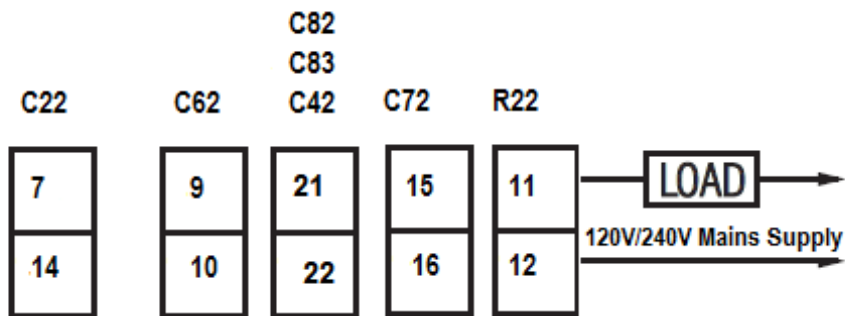

**2-37 Alarm 2 Output to Drive Load**

**2.8.3 Alarm 3**

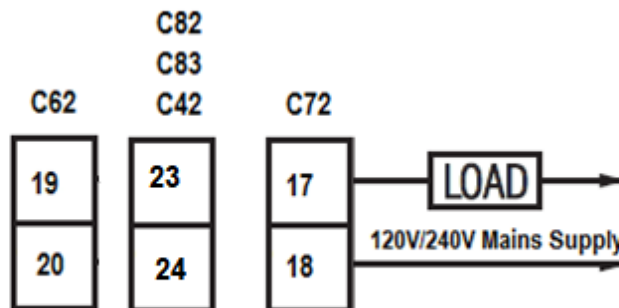

**2-38 Alarm 3 Output to Drive Load**

## 2.8.4 Alarm 4

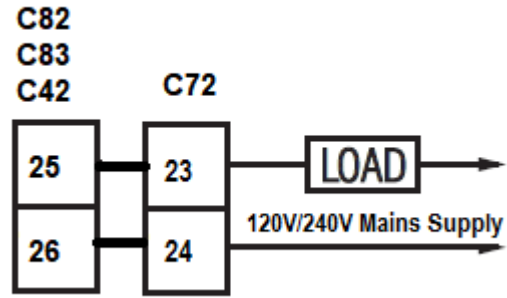

2-39 Alarm 4 Output to Drive Load

## 2.9 Event Input Wiring

The event input can accept a switch (dry contact) or an open collector signal. The event input function (EIFN) is activated as the switch is closed or an open collector (or a logic signal) is pulled down.

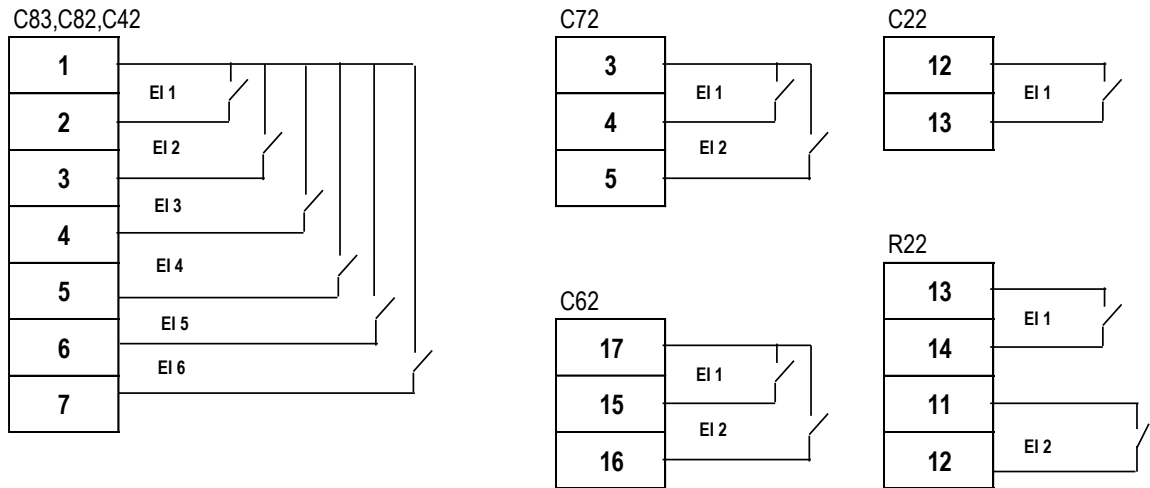

2-40 Event Input Wiring



## 2.10 CT Input Wiring

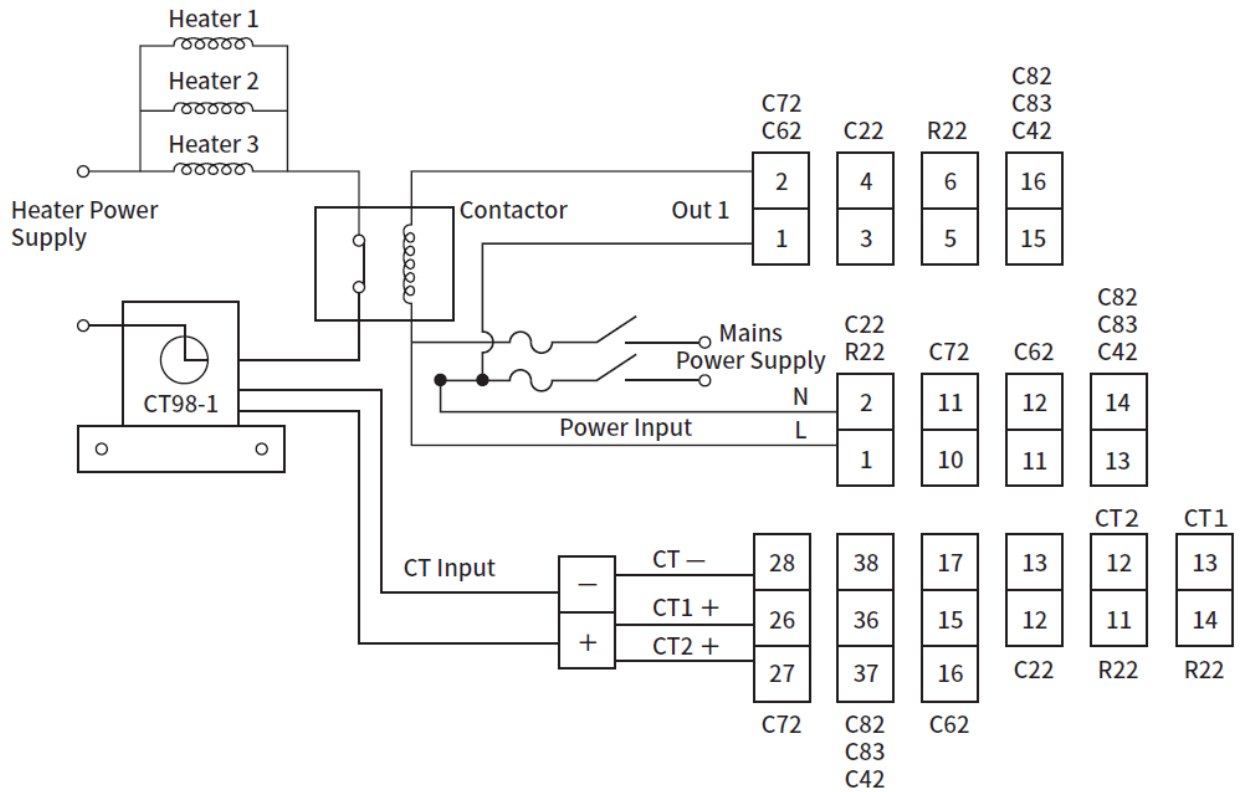

2-41 CT Input Wiring for Single Phase Heater

## 2.11 RS-485 Data Communication

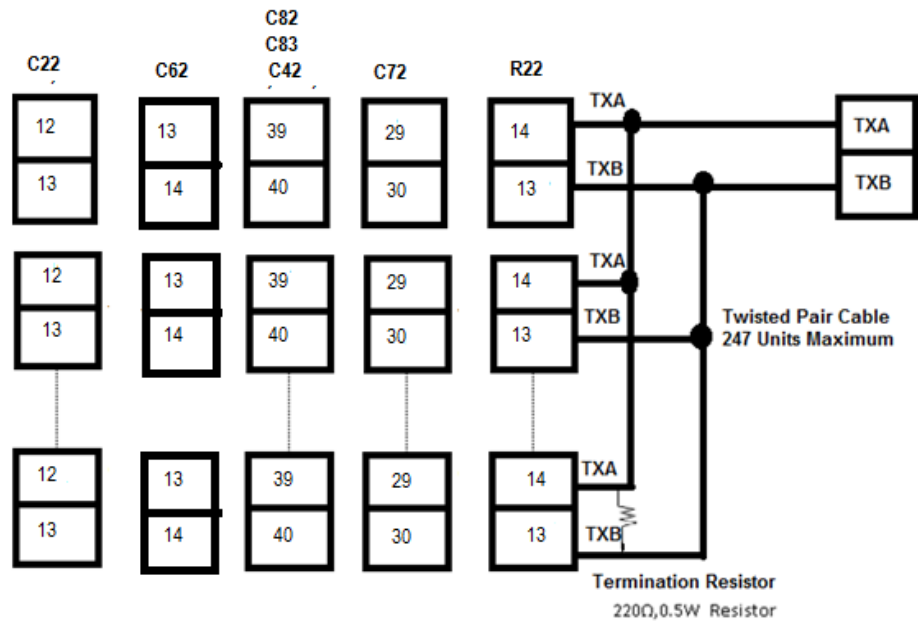

2-42 RS-485 Wiring

## 2.12 Retransmission Wiring

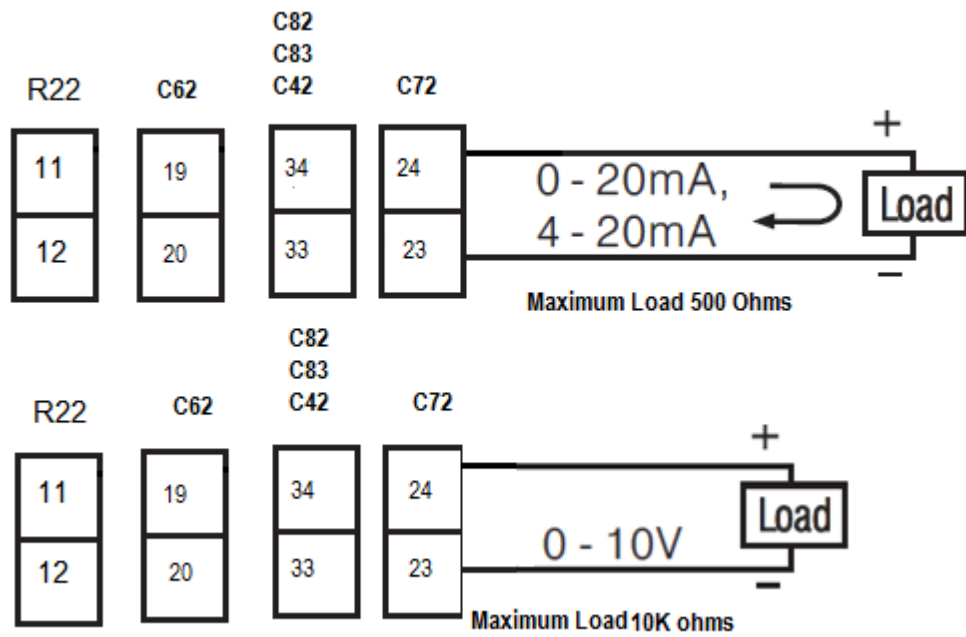

**2-43 Retransmission Wiring**

**2.13 Remote Setpoint Wiring**

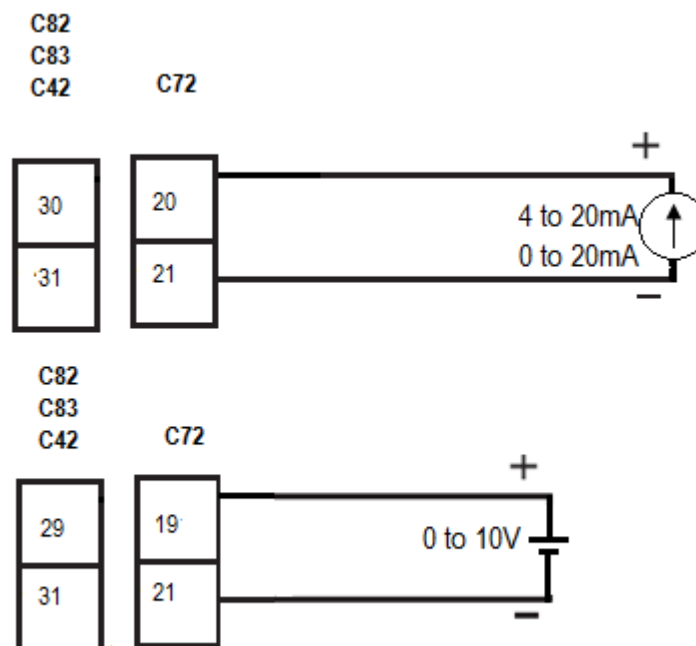

**2-44 Remote SetPoint**

### 3 Programming

Press  $\square$  for 5 seconds and release to enter the setup menu. Press and release  $\square$  to select the desired parameter. The upper display indicates the parameter symbol, and the lower display indicates the value of the selected parameter.

#### 3.1 User Security

There are two parameters PASS (password) and CODE (security code) which will control the data security function.

CODE Value	PASS Value	Access Rights
0	Any Value	All parameters are changeable
1000	=1000	All parameters are changeable
	≠1000	User menu parameters only changeable
500	=500	All parameters are changeable
	≠500	All parameters are changeable except calibration menu parameters
9999	=9999	All parameters are changeable
	≠9999	SP1 to SP7 only changeable
Others	=CODE	All parameters are changeable
	≠CODE	No parameters can be changed

#### 3-1 User Access Rights

**Note:** CODE parameter will not be visible when CODE≠PASS except the CODE value 0 and 500.

#### 3.2 Signal Input

**INPT:** Select the sensor type or signal type for signal input

**Range:** (Thermocouple) J<sub>tC</sub>, K<sub>tC</sub>, T<sub>tC</sub>, E<sub>tC</sub>, B<sub>tC</sub>, R<sub>tC</sub>, S<sub>tC</sub>, N<sub>tC</sub>, L<sub>tC</sub>, U<sub>tC</sub>, P<sub>tC</sub>, C<sub>tC</sub>, d<sub>tC</sub>, LJtC

(RTD) PT. DN, PT.JS

(Linear) 4-20mA, 0-20mA, 0-5V, 1-5V, 0-10V, 0-50mV

**UNIT:** Select the processing unit

**Range:** °C, °F, PU (Process unit). If the unit is neither °C nor °F, then selects PU.

**DP:** Select the resolution of the process value.

**Range:** For Thermocouple and RTD Signal NO. DP, 1-DP and For Linear Signal NO. DP, 1- DP, 2-DP, 3-DP

**INLO:** Select the low scale value for the linear type input.

**INHI:** Select the high scale value for the linear type input.

**How to use INLO and INHI:**

If 4-20mA is selected for INPT, let SL represent the low scale of the input signal (i.e. 4 mA), let SH represent the high scale of the input signal (i.e. 20 mA). S represents the current input signal value; the conversion curve of the process value is shown as follows:

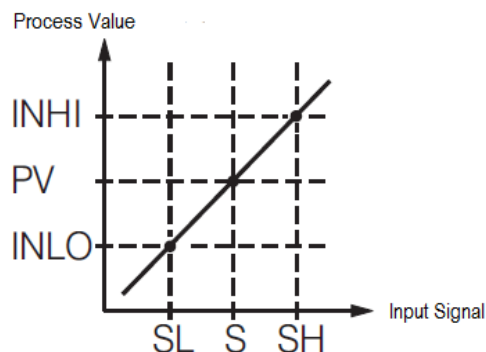

3-1 Conversion Curve for Linear Type Process Signal

Formula:  $PV = INLO + (INHI - INLO) \left( \frac{S - SL}{SH - SL} \right)$

Example: A 4-20mA current loop pressure transducer with a range of 0-15 kg/cm is connected to the input. The following parameters should be set as follows:

INPT = 4-20, INLO = 0.00, INHI = 15.00, DP = 2-DP

Of course, the user may select a different value for DP to alter the resolution.

### 3.3 Control Output

There are 4 kinds of control modes can be configured as shown below.

Control Mode	OUT 1	OUT 2	O1HY	CPB	DB
Heat Only	REVR	X	Δ	X	X
Cool Only	DIRT	X	Δ	X	X
Heat PID, Cool ON-OFF	REVR	COOL	X	X	X
Heat PID, Cool PID	REVR	COOL	X	O	O

#### 3-2 Control Mode

X: Not applicable

O: Adjust to meet process Requirements

Δ: Required if ON-OFF Control is configured

#### 3.3.1 Heat Only ON-OFF Control

Select REVR for OUT1, Set PB to 0. O1HY is used to adjust the dead band for ON-OFF control. The output 1 hysteresis (O1HY) setting becomes available when PB = 0. The heat only ON-OFF control function is shown below.

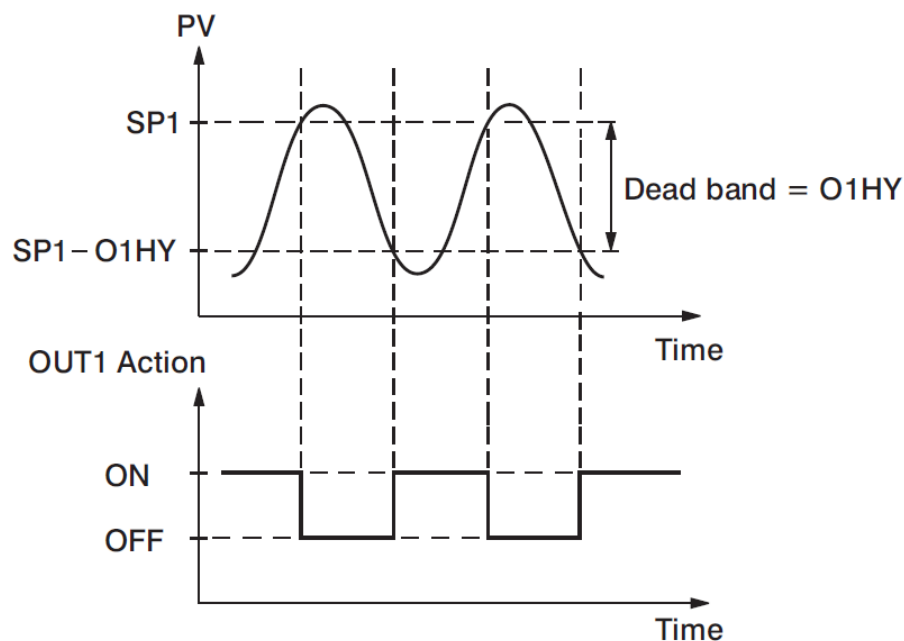

#### 3-2 Heat Only ON-OFF Control

ON-OFF control may cause excessive process oscillations even if the hysteresis is set to the smallest value. If ON-OFF control is set (i.e. PB = 0), TI, TD, CYC1, OFST, CYC2, CPB, DB will no longer be applicable and will be hidden. Auto-Tuning mode and Bumpless transfer will also be unavailable.

#### 3.3.2 Heat only P or PD Control

Select REVR for OUT1 set TI = 0, OFST is used to adjust the controlled offset (manual reset). If PB ≠ 0 then O1HY will be hidden.

**OFST Function:** OFST is measured in % with a range of 0 - 100.0 %. When the process is stable, let's say the process value is lower than the setpoint by 5°C. Let's also say that 20 is used for the PB setting. In this example, 5°C is 25% of the proportional band (PB).

By increasing the OFST value by 25%, the control output will adjust itself, and the process value will eventually coincide with the set point.

When using Proportional (P) control (TI = 0), Auto-Tuning will be unavailable. Refer to "manual tuning" section for the adjustment of PB and TD. Manual reset (OFST) is usually not practical because the load may change from time to time; meaning the OFST setting would need to be constantly adjusted. PID control can avoid this problem.

### 3.3.3 Heat only PID Control

Select REVR for OUT1. PB and TI should not be zero. Perform Auto-Tuning for initial startup, or set PB, TI and TD using historical values. If the control result is not satisfactory, use manual or Auto-Tuning to improve the control performance. The unit contains a very clever PID and Fuzzy algorithm to achieve the set point with a very small overshoot and very quick response to the process if it is properly tuned.

### 3.3.4 Cool only Control

ON-OFF control, P (PD) control and PID control can be used for cooling control. Set OUT1 to DIRT (direct action). The other functions for cooling only are ON-OFF control, cool only P (PD) control and cool only PID control are same as for heating, except that the output variable (and action) is reversed.

**NOTE:** ON-OFF control may result in excessive overshoot and undershoot problems in the process. P (or PD) control will result in a deviation of the process value from the setpoint. It is recommended to use PID control for Heat-Cool control to produce a stable and zero offset process value.

### 3.3.5 Other Setup Required

O1TY, CYC1, O2TY, CYC2, O1FT, O2FT O1TY & O2TY are set per the type of outputs installed (OUT1 & OUT2) installed. CYC1 & CYC2 are set according to the output 1 type (O1TY) & output 2 type (O2TY). Generally, if SSRD or SSR is used for O1TY, CYC1 is set to a value of 0.5 - 2 seconds. If a Relay is used for O1TY, CYC1 is set to a value of 10 - 20 seconds. If a linear output is used, CYC1 is not applicable. The similar conditions are applied for CYC2 selection.

The user can use Auto-Tuning program for initial start-up, or they can directly set the appropriate values for PB, TI & TD using the historical records for repeat systems. If the control behaviors are still inadequate, then manual tuning may be required to improve control.

### 3.3.6 CPB Programming

The cooling proportional band is measured by % of PB with a range of 50~300. Initially, set 100% for CPB and examine the cooling effect. If the cooling action should be enhanced, decrease the CPB value. If the cooling action is too strong, increase the CPB value. The value of CPB is directly proportional to the PB setting. Its value remains unchanged throughout the Auto-Tuning process.

Adjustment of CPB is related to the cooling media used. If air is used as a cooling media, set the CPB to 100(%). If the oil is used as the cooling media, set the CPB to 125(%). If water is used as the cooling media, set the CPB to 250(%).

### 3.3.7 DB Programming

Adjustment of DB (Dead band) is dependent on system requirements. If a greater dead band is used, then an unwanted cooling action can be avoided, but an excessive overshoot of the setpoint will occur. If a smaller dead band (DB) is used, then an excessive overshoot can be minimized, but an overlapping of the heating and cooling action will occur. The DB setting is adjustable in the range of -36.0% to 36.0 % of PB.

A negative DB value will have an overlap where both outputs are active. A positive DB value has a dead band area where neither output is active.

### 3.3.8 Output 2 ON-OFF Control (Alarm function)

Output 2 can also be configured as an alarm output. There are 13 kinds of alarm functions and a Dwell timer (dtMR) that can be selected for output 2. They are dtMR (Dwell Timer), dE. HI (deviation high alarm), dE. Lo (deviation low alarm), dB. Hi (Out of band alarm), dB. Lo (In-band Alarm), PV. HI (process value high alarm), PV. LO (process value low alarm), H. bK (Heater Break Alarm), H. St (Heater Short Alarm), RG. HI (Range high alarm), RG. Lo (Range low alarm), RG.H. L (Range high low alarm), PF.Hb (Profile Holdback) and PF.Ed (Profile End).

### 3.4 Soft-Start

The controller has a soft start function to limit the control output on out1 and out2 for a programmable time SFT or up to a programmed threshold value SFTH. The first of two will terminate soft-start function and the normal PID control begins. This function is useful for effects such as suppressing the heater output during equipment startup or lightening the load.

**Note:** In Profile Version Controllers If PFR is set to other than SP1 then the profile function will continue with the set parameter during power recovery. If PFR is set to SP1 then the profile will continue to run with soft start parameters during power recovery.

There are 5 parameters available for the soft-start function. They are as below.

1. **SFt:** Soft start time. If the SFt  $\neq$  0 then the Soft start function will be enabled. The SFt can be set in the form of Hour: Minute. The range can be set is 00:00 to 99:59.
2. **SFL1:** Soft Start output limit for output 1. It can be set from PL1L to PL1H.
3. **SFL2:** Soft Start output limit for output 2. It can be set from PL2L to PL2H.
4. **SFtH:** Soft start threshold value. The Soft start will be aborted when the process value is greater than or equal to SFtH.
5. **SFtR:** Soft start time. It will show the remaining time of soft start when it is running.

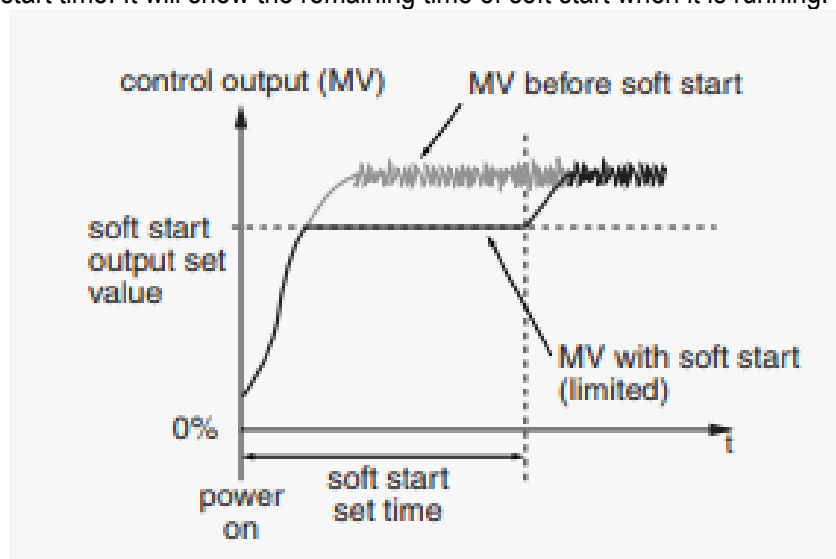

3-3 Soft Start Function

### 3.5 Alarm

The controller has up to four alarm outputs depending on the controller model. There are 16 types of alarm functions and one dwell timer that can be selected. There are 4 kinds of alarm modes (A1MD, A2MD, A3MD, and A4MD) available for each alarm function (A1FN, A2FN, A3FN, and A4FN). In addition to the alarm output, output 2 can also be configured as an alarm. But output 2 has only provided 14 different alarm functions or dwell timer available.

### 3.5.1 Alarm Types

There are 11 different types of alarms as listed below that the user can assign to different alarm outputs.

0. **NoNE**: No Alarm function
1. **dtMR**: Dwell timer
2. **dE. HI**: Deviation high alarm
3. **dE. Lo**: Deviation low alarm
4. **dB. Hi**: Deviation band out of band alarm
5. **dB. Lo**: Deviation band in band alarm
6. **PV. HI**: Process value high alarm
7. **PV. Lo**: Process value low alarm
8. **H. bK**: Heater break alarm
9. **H. St**: Heater short alarm
10. **E1.C.o**: Event Input 1 Control Alarm Output
11. **E2.C.o**: Event Input 2 Control Alarm Output
12. **RG. HI**: Range high alarm
13. **RG. Lo**: Range low alarm
14. **RG.H. L**: Range high low alarm
15. **PF. Hb**: Profile Holdback alarm
16. **PF. Ed**: Profile End

The **dwell timer** can be used separately or accompanied with a Ramp. Alarm outputs can be configured as dwell timers by selecting dtMR for A1FN. If A1FN is set to DTMR, Alarm 1 will act as a dwell timer. Similarly, Alarm 2, Alarm3 or Alarm4 will act as dwell timers if A2FN, A3FN, or A4FN is set to dtMR. When the dwell timer is configured, the parameter DTMR is used for dwell time adjustment. The time mentioned in DTMR is in the format of minute: seconds. The seconds' value mentioned has the multiplication factor of 6.

A deviation alarm alerts the user when the process value deviates too far from the set point. When the process value is higher than  $SV + AxDV$ , a **deviation high alarm (dE. HI)** occurs. The alarm is off when the process value is lower than  $SV + AxDV - AxHY$ .

When the process value is lower than  $SV + AxDV$ , a **deviation low alarm (dE. Lo)** occurs. The alarm is off when the process value is higher than  $SV + AxDV + AxHY$ . The trigger level of a deviation alarm moves with the setpoint.

A deviation band alarm presets two trigger levels centred on the set point. The two trigger levels are  $SV + AxDV$  and  $SV - AxDV$ . When the process value is higher than  $(SV + AxDV)$  or lower than  $(SV - AxDV)$ , a **deviation band out of band alarm (dB. HI)** occurs. When the process value is within the trigger levels, a **deviation band in band alarm (dB. Lo)** occurs. In the above descriptions, SV denotes the current setpoint value for the control. This is different from SP1 when the ramp function is used.

A process alarm can set two absolute trigger levels. When the process value is higher than  $AxSP$ , a **process high alarm (PV. HI)** occurs. The alarm is off when the process value is lower than  $AxSP - AxHY$ .

When the process value is lower than  $AxSP$ , a **process low alarm (PV. Lo)** occurs. The alarm is off when the process is higher than  $AxSP + AxHY$ . A process alarm is independent of the set point.

Heater break detection is enabled by setting A1FN to HBEN. A **Heater break alarm (H. bK)** alerts the user when the current measured by CT1 in CT1R is lower than HB1T, or CT2 in CT2R is lower than HB2T. When the current measured by CT1 in CT1R is higher than HB1T+HBHY and CT2 in CT2R is lower than HB2T+HBHY, the heater break alarm will be off. The Heater break alarm will be off when both CT values are in the normal range. This Alarm will function when output1 is in ON condition only.

The Heater short detection is enabled by setting A1FN to HSEN. A **Heater short alarm (H. St)** alerts the user when the current measured by CT1 in CT1R is higher than HS1T, or CT2 in CT2R is higher than HS2T. When the current measured by CT1 in CT1R is lower than HS1T-HSHY and CT2 in CT2R is lower than HS2T-HSHY, the heater short alarm will be off. The Heater short alarm will be off when both CT values are in the normal range. This Alarm will function when output1 is in OFF condition only.

*Note: The Heater break and Heater short alarms will work only with Relay and SSR outputs in output1.*

The Alarm outputs can be controlled by Event input1 and Event input 2 by selecting **Event Input 1 Control Alarm Output (E1. C.o.)** and **Event Input 2 Control Alarm Output (E2. C.o.)** for alarm function A2FN and A3FN. The output will be ON as long as the event input is ON. The output will go OFF when the input is OFF.

Range alarm will alert the user when the process value reaches the range. When the process value is equal to  $SV + AxSP - AxDV$  or  $SV + AxSP$ , a **Range hi (RG. HI)** alarm will occur. The alarm is off when the process value is greater than  $SV + AxSP + AxHY$  or lower than  $SV + AxSP - AxDV - AxHY$ .

*Note: The  $SV + AxSP - AxDV$  or  $SV + AxSP$  can't be less than SV in range high alarm. The AxSP and AxDV have to be configured according to this condition.*

When the process value is equal to  $SV - AxSP + AxDV$  or  $SV - AxSP$ , a **Range low (RG. Lo)** alarm will occur. The alarm is off when the process value is lower than  $SV - AxSP - AxHY$  or greater than  $SV - AxSP + AxDV + AxHY$ .

*Note: The  $SV - AxSP + AxDV$  or  $SV - AxSP$  can't be higher than SV in range low alarm. The AxSP and AxDV have to be configured according to this condition.*

The **Range Hi-Low alarm (RG.H.L.)** will include both Range Hi and Range Low. In the above description, Ax denotes the respective alarm parameters such as A1, A2, A3, A4.

*Note: The AxDV can't be set to less than 0.1 in range alarm.*

The **Profile Holdback (PF. Hb)** alarm will alert the user when the profile is in Holdback state. The **Profile End (PF. Ed)** alarm will alert the user when the profile end.

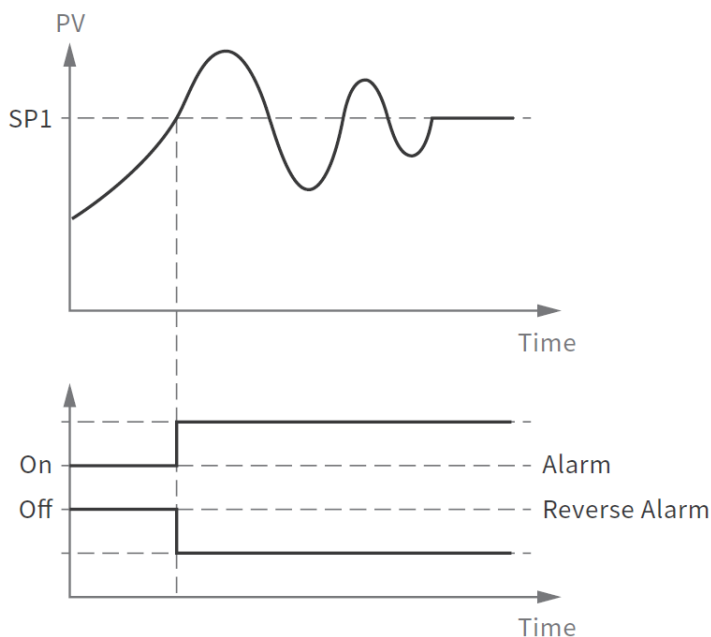

### 3-4 Dwell Timer (dtMR)



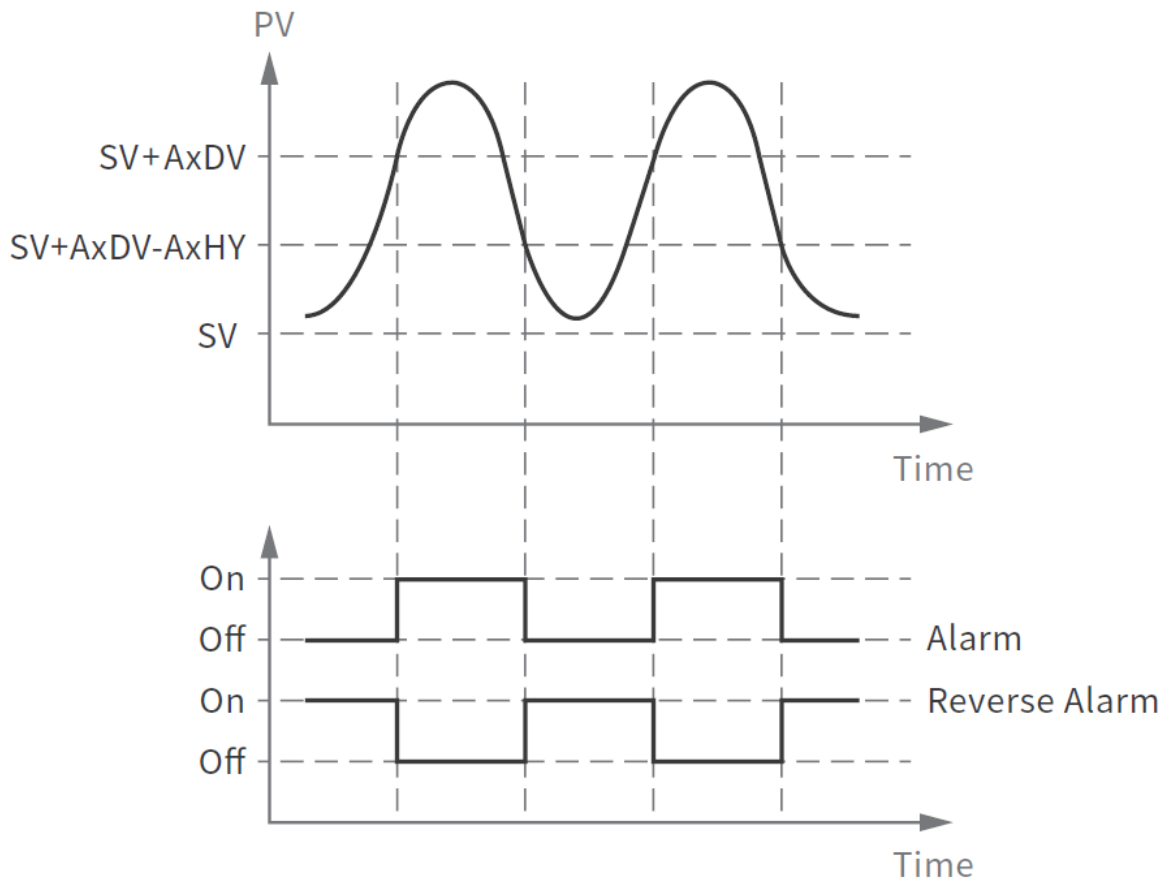

**3-5 Deviation High Alarm (dE.HI)**

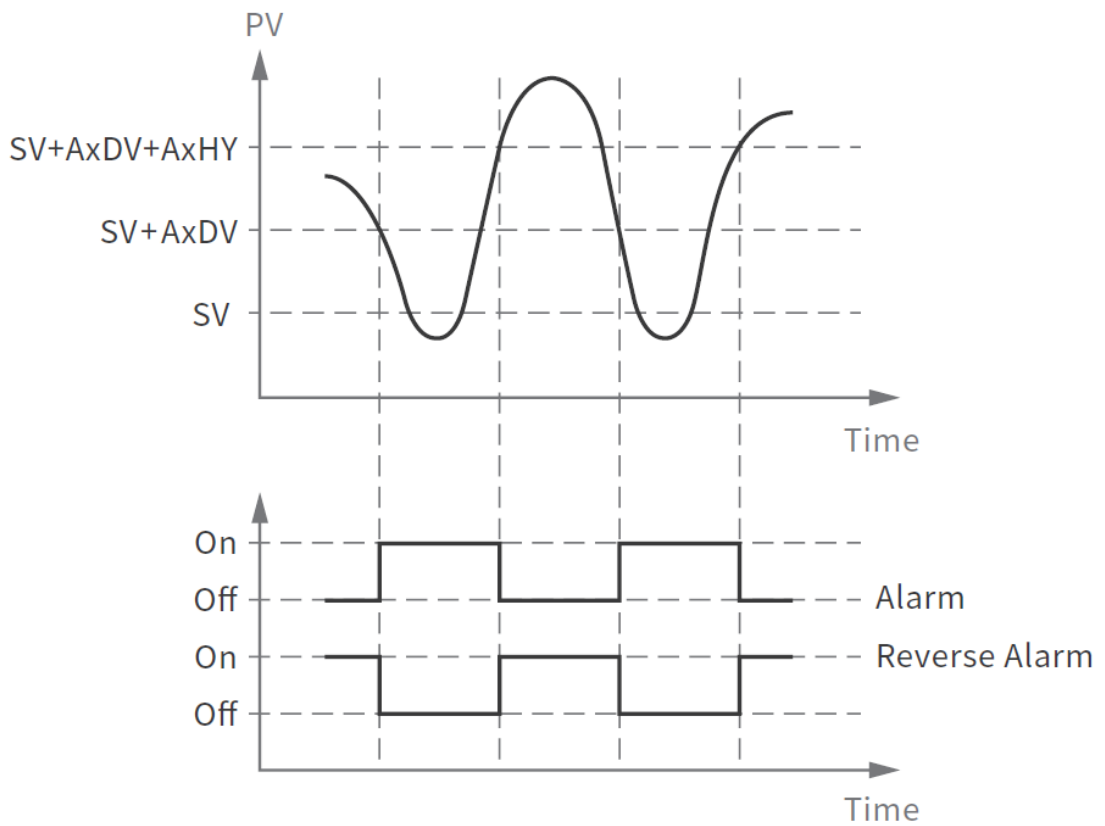

**3-6 Deviation Low Alarm (dE.Lo)**

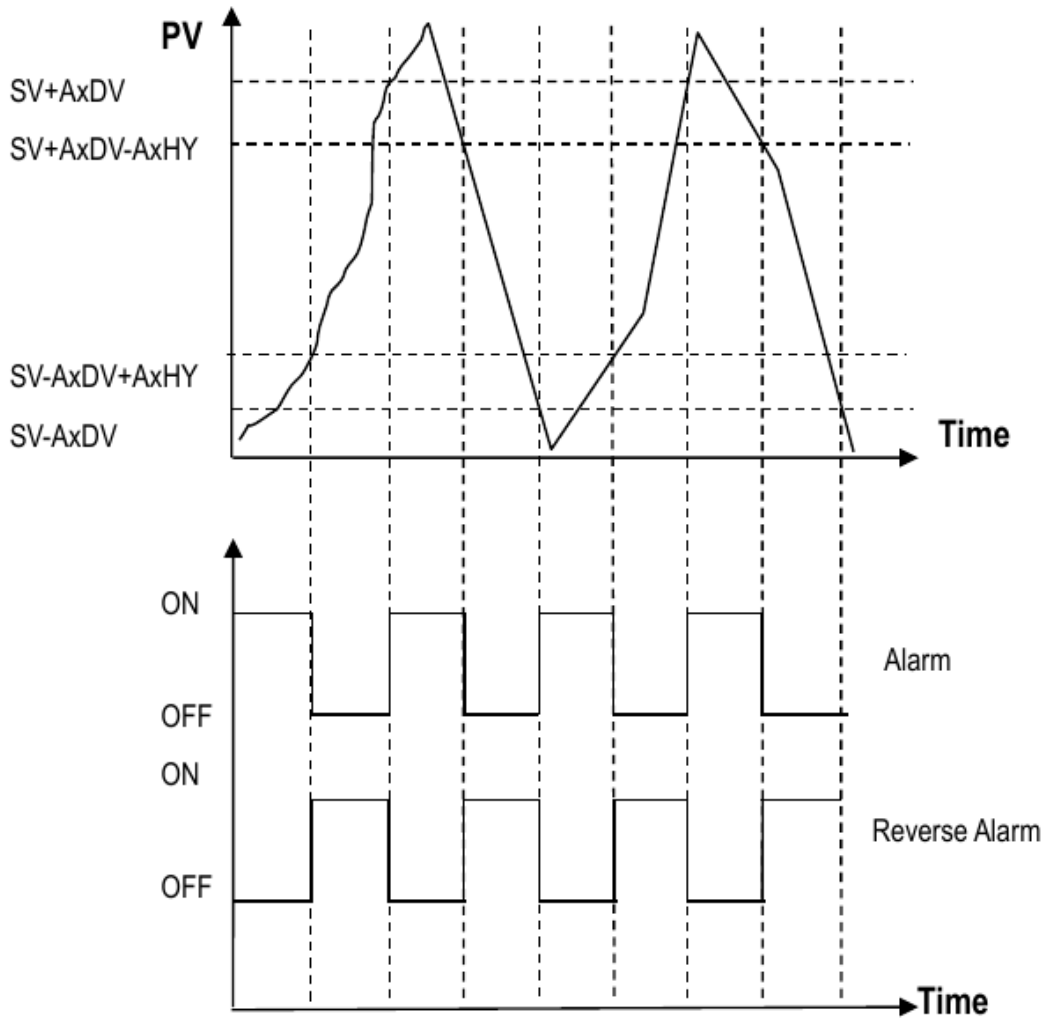

**3-7 Deviation out of Band Alarm (db.HI)**

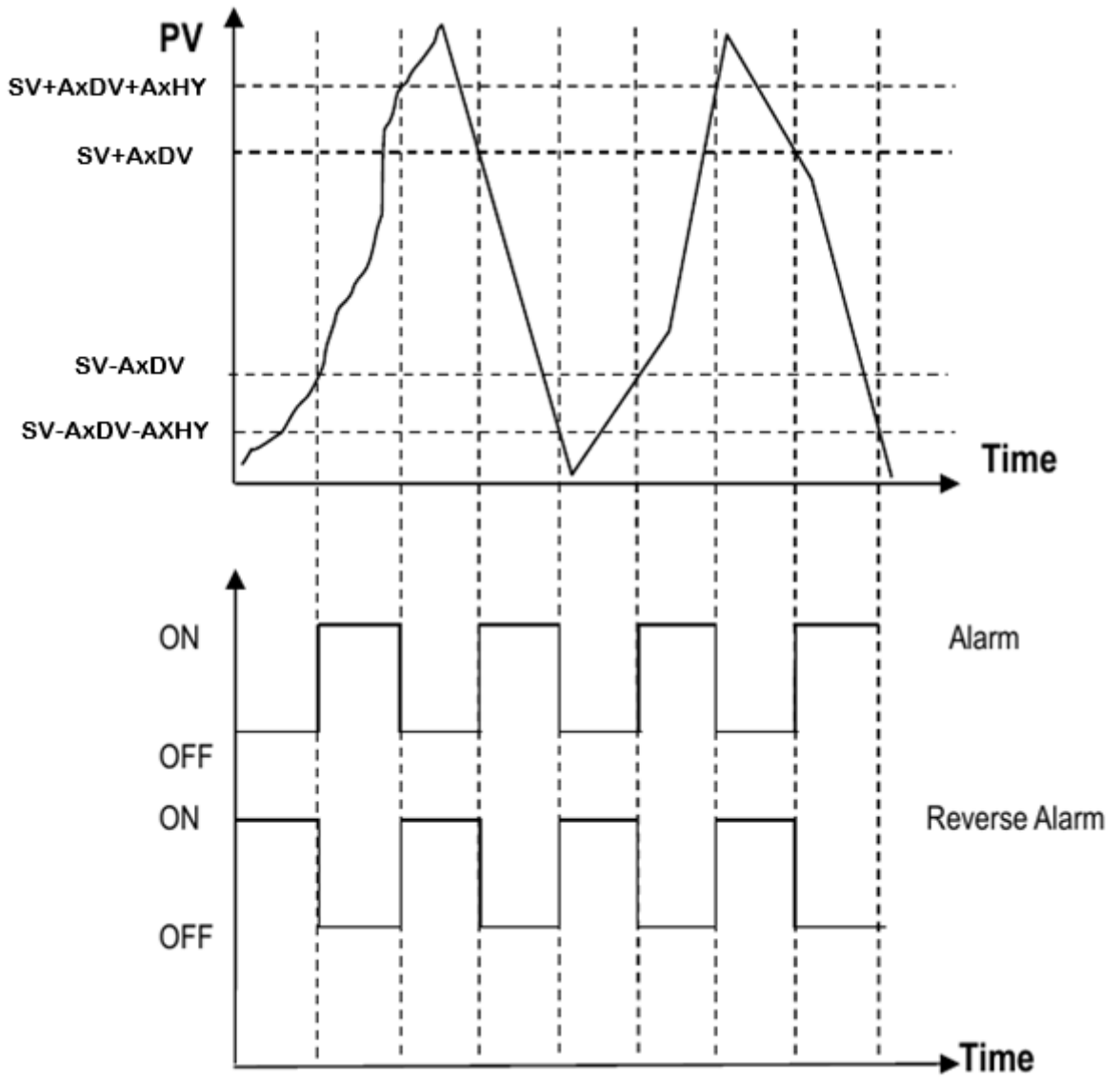

**3-8 Deviation In-Band Alarm (db.Lo)**

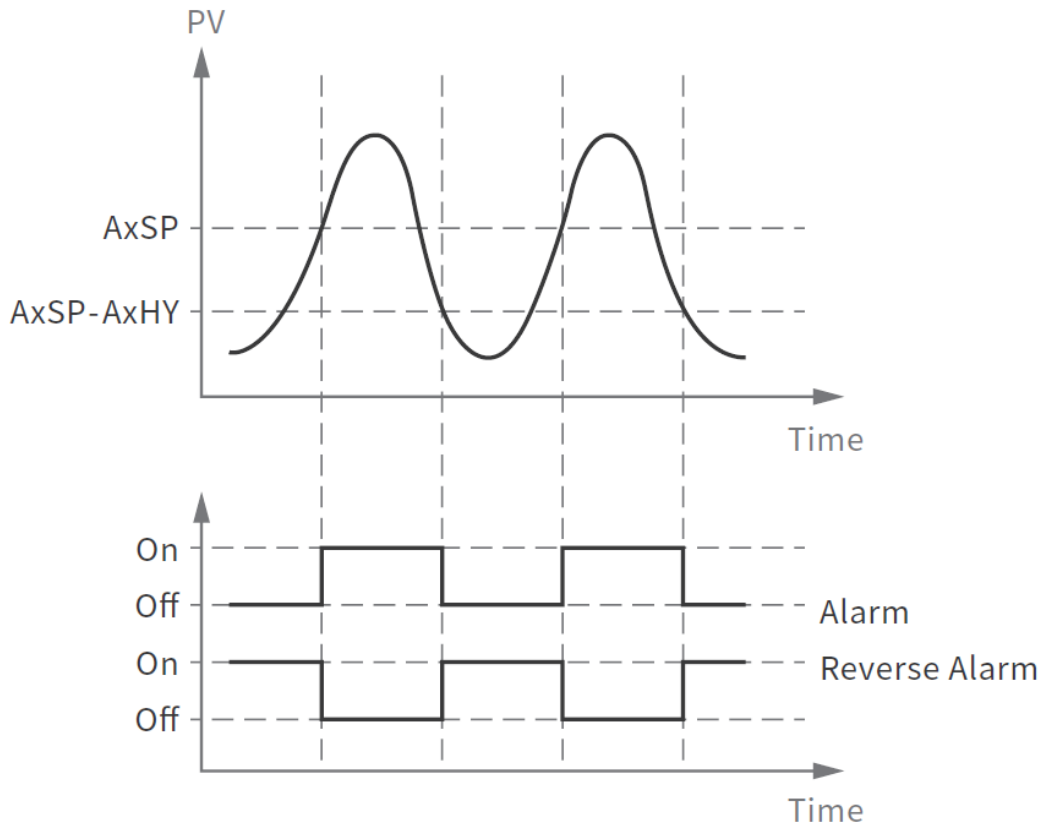

**3-9 Process Value High (PV.HI)**

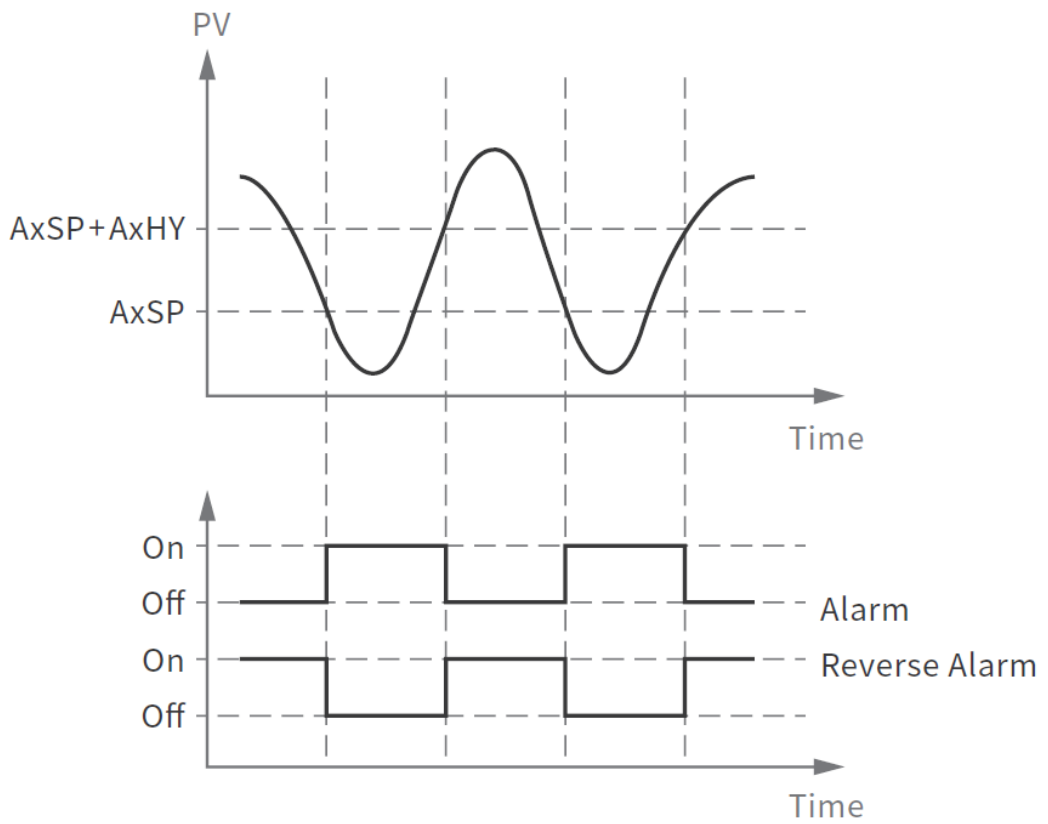

**3-10 Process Value Low (PV.Lo)**

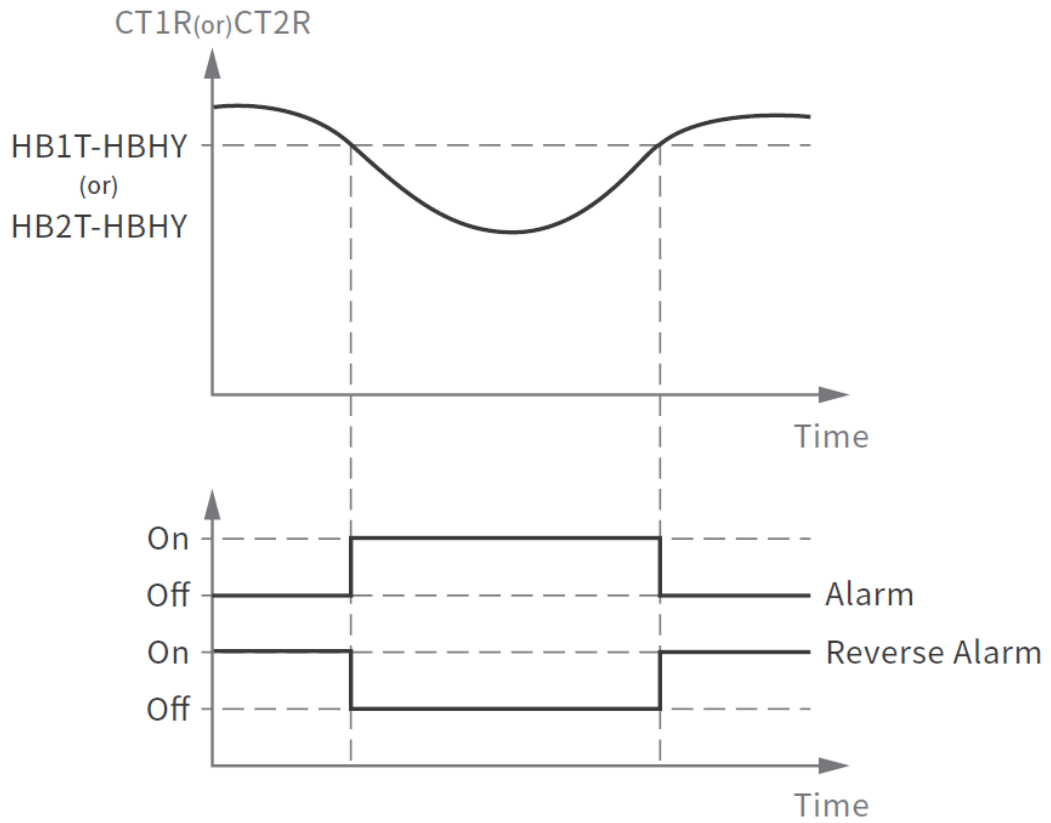

**3-11 Heater Break (H.bk)**

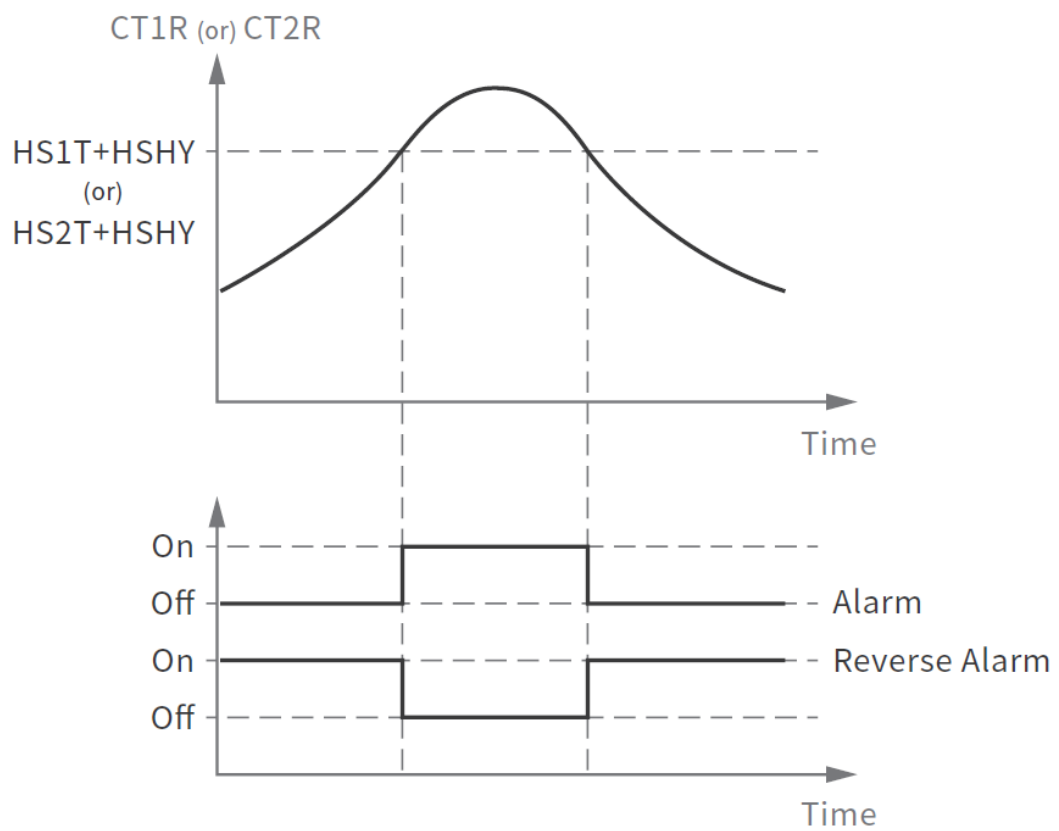

**3-12 Heater Short (H.St)**

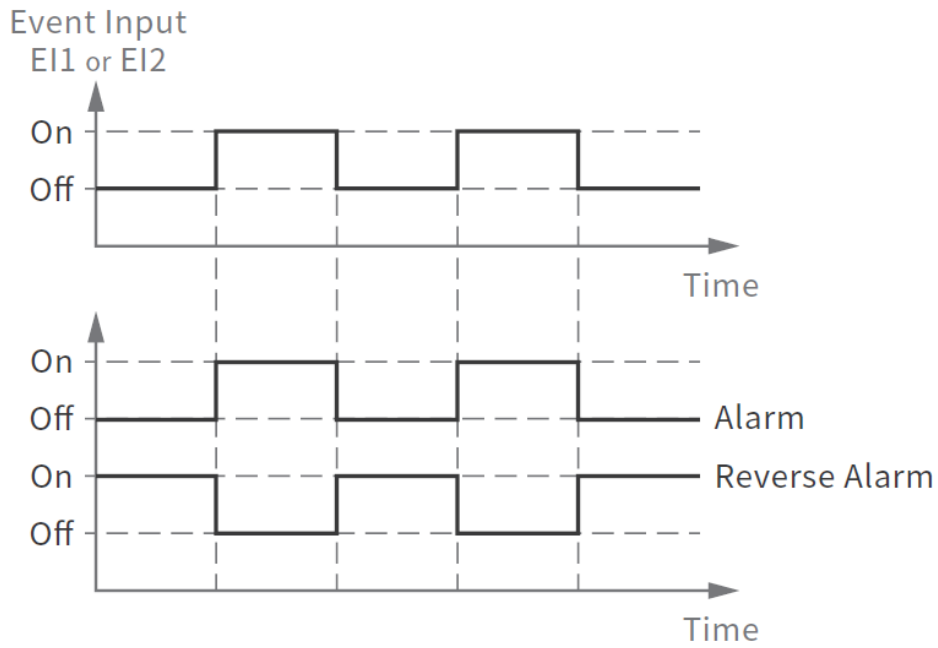

**3-13 Event Input Controlled Output (E1.C.o or E2.C.o.)**

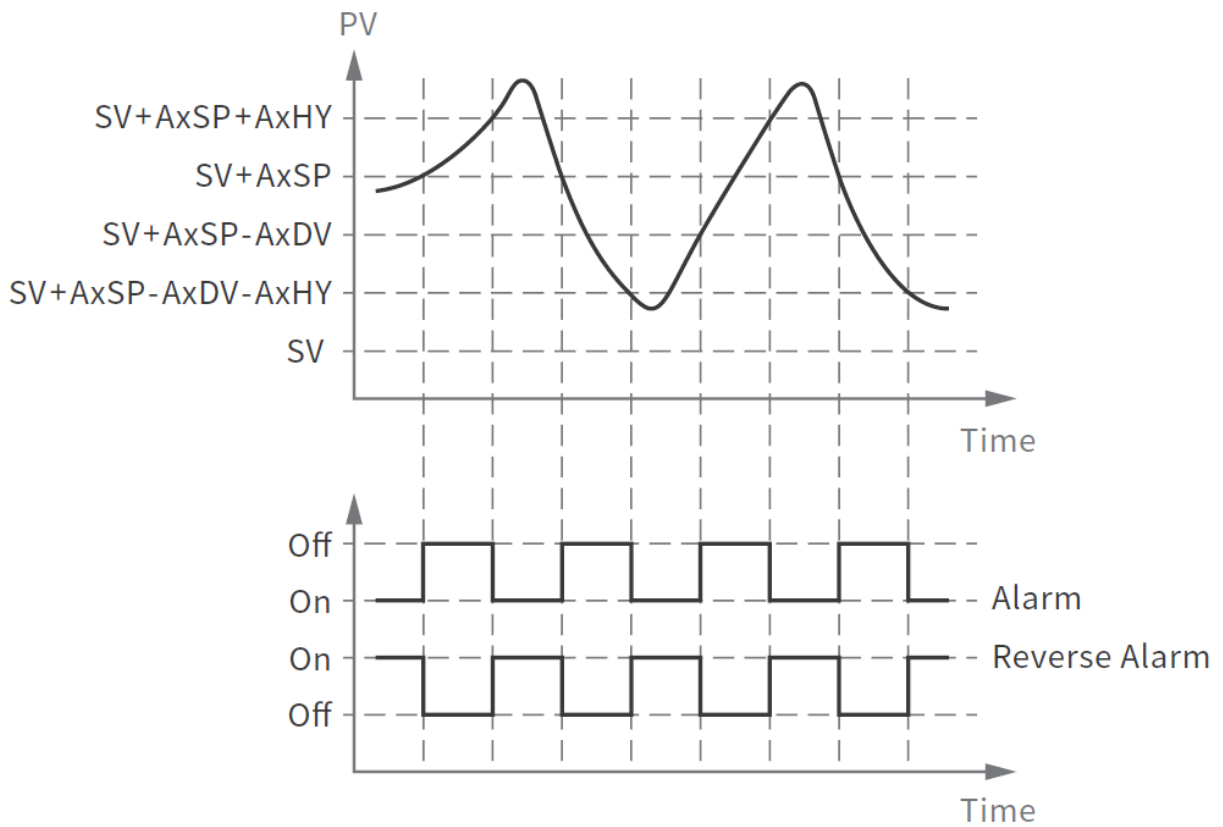

**3-14 Range High (RG.HI)**

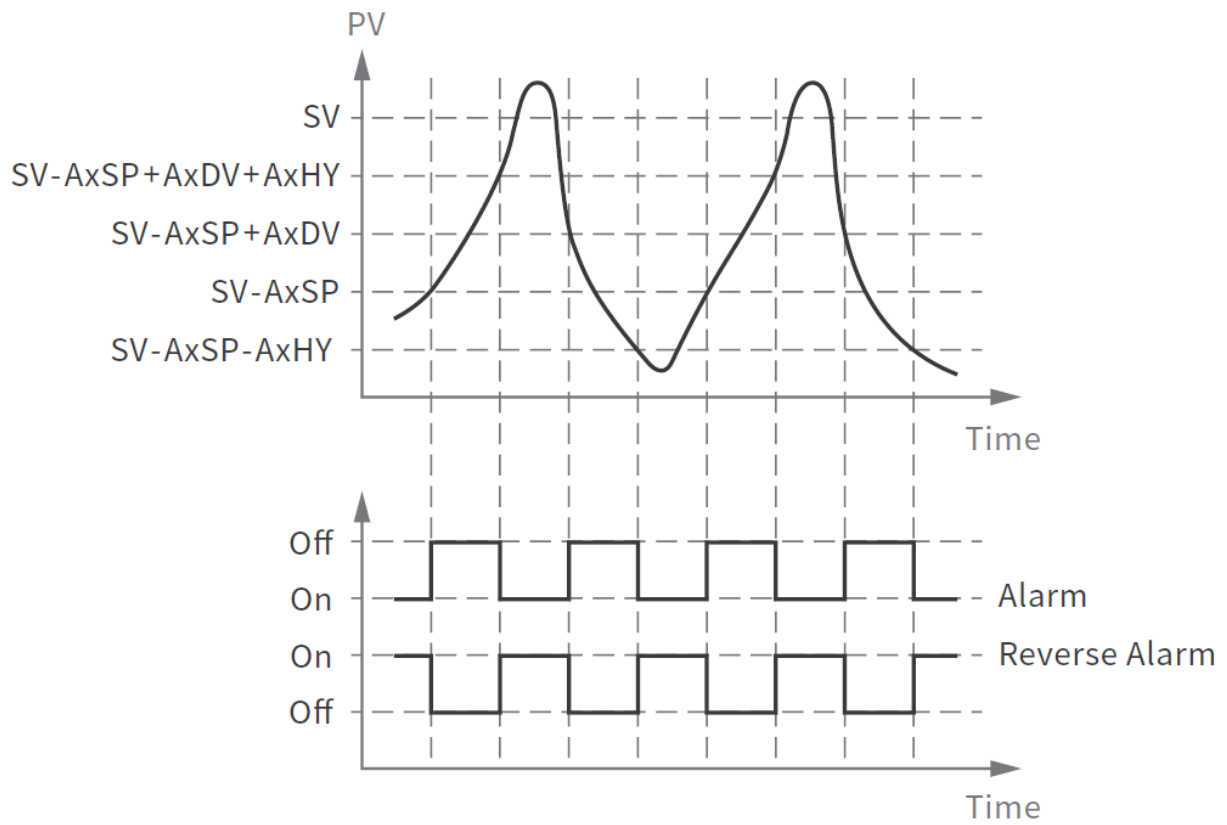

**3-15 Range Low (RG.Lo)**

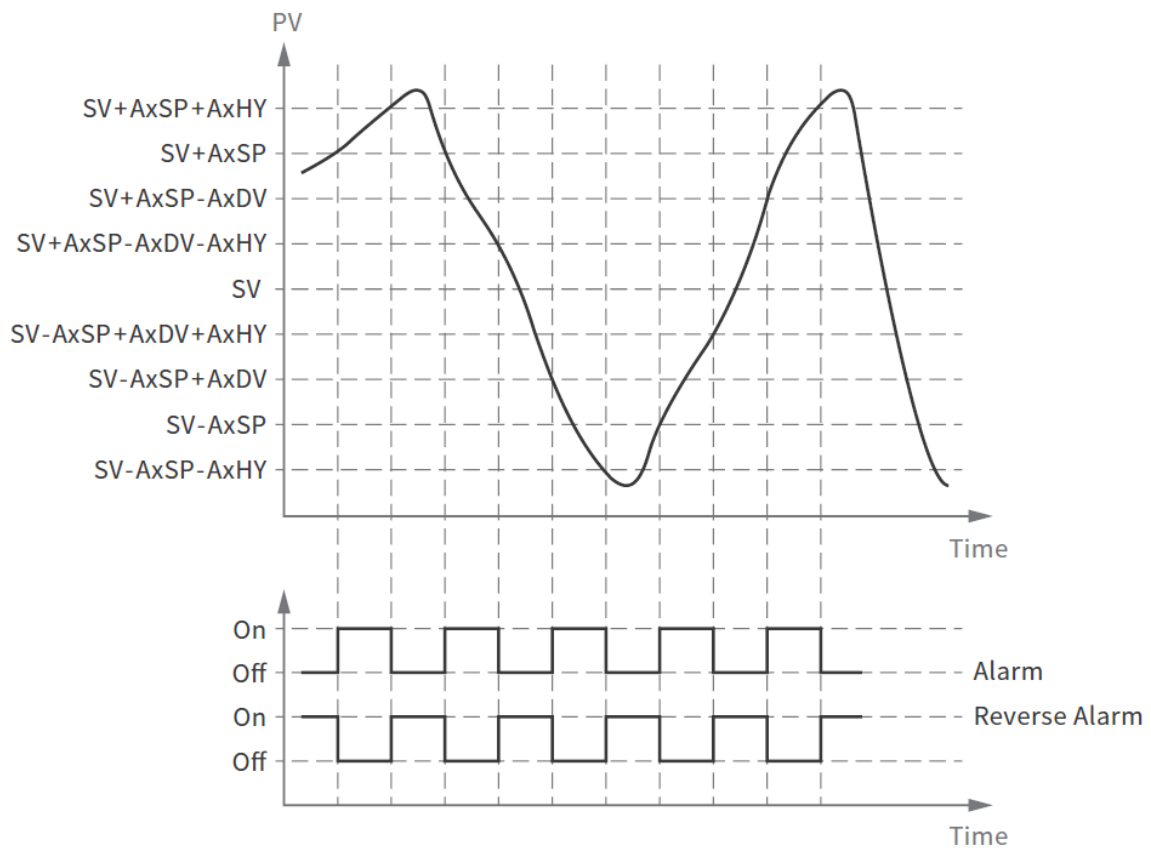

**3-16 Range High Low (RG.H.L)**

### 3.5.2 Alarm Modes

There are six types of alarm modes available for each alarm function.

1. Normal alarm
2. Latching alarm
3. Holding alarm
4. Latching/ Holding alarm
5. Setpoint Holding Alarm
6. Latching None Reset Alarm

#### 3.5.2.1 Normal Alarm: *ALMD = NORM*

When a normal alarm is selected, the alarm output is de-energized in the non-alarm condition and energized in an alarm condition.

#### 3.5.2.2 Latching Alarm: *ALMD = LTCH*

If a latching alarm is selected, once the alarm output is energized, it will remain unchanged even if the alarm condition is cleared. The latching alarm can be reset by pressing the RESET key once the alarm condition is removed.

#### 3.5.2.3 Holding Alarm: *ALMD = HOLD*

A holding alarm prevents an alarm condition during power-up. Only if the PV meets the Alarm condition as soon as the controller is powered on, setting the holding Alarm will ignore the alarm condition for the first time after powering on. Afterward, the alarm performs the same function as a normal alarm. If the condition is not as described above, the holding alarm will work as the regular alarm.

#### 3.5.2.4 Latching / Holding Alarm: *ALMD = LT. HO*

A latching/holding alarm performs both holding and latching functions. The latching alarm is reset when the RESET key is pressed after the alarm condition is removed.

#### 3.5.2.5 Setpoint Holding Alarm: *ALMD = SP. HO*

A setpoint holding alarm prevents an alarm from power-up and/or changing set point. The alarm output is de-energized whenever the setpoint is changed even if it is in an alarm condition. The alarm reverts to a normal alarm once the alarm condition is removed.

#### 3.5.2.6 Latching None Reset Alarm = *Lt.N.R*

This mode is the same as Latching alarm. But the alarm can't be reset by the Reset Key on the controller. The alarm reset can be done only by using an event input alarm reset function.



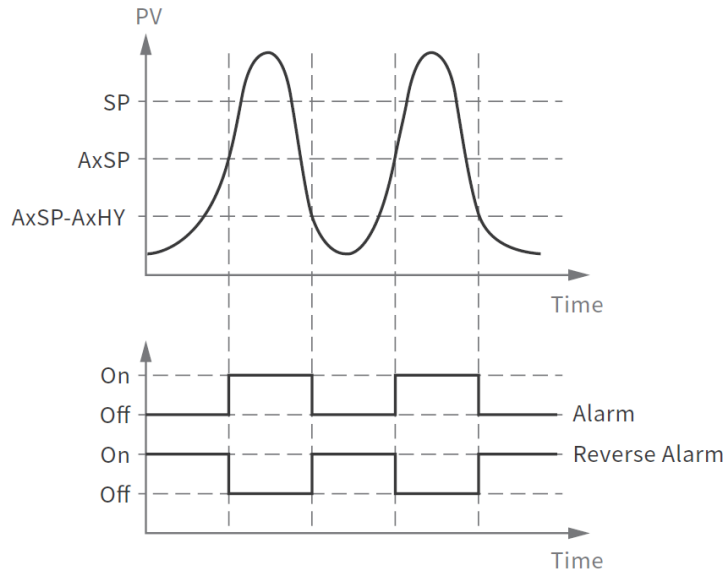

**3-17 Process Value High- Normal Alarm**

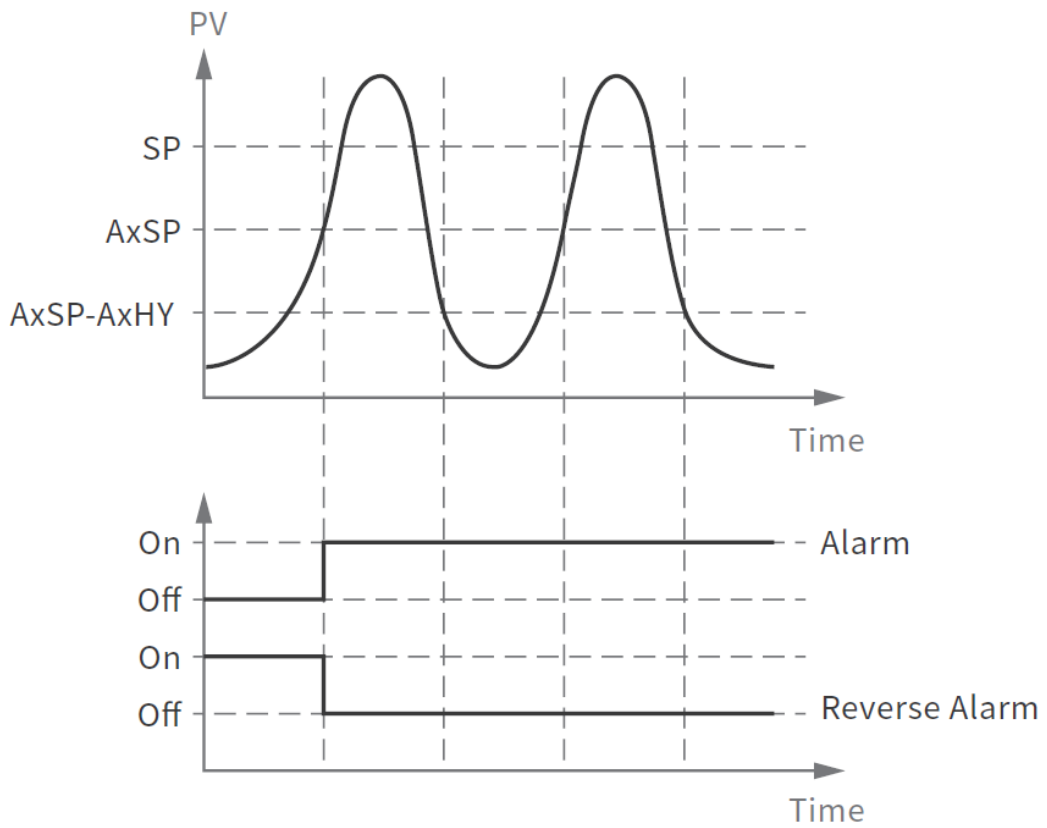

**3-18 Process Value High- Latching Alarm**

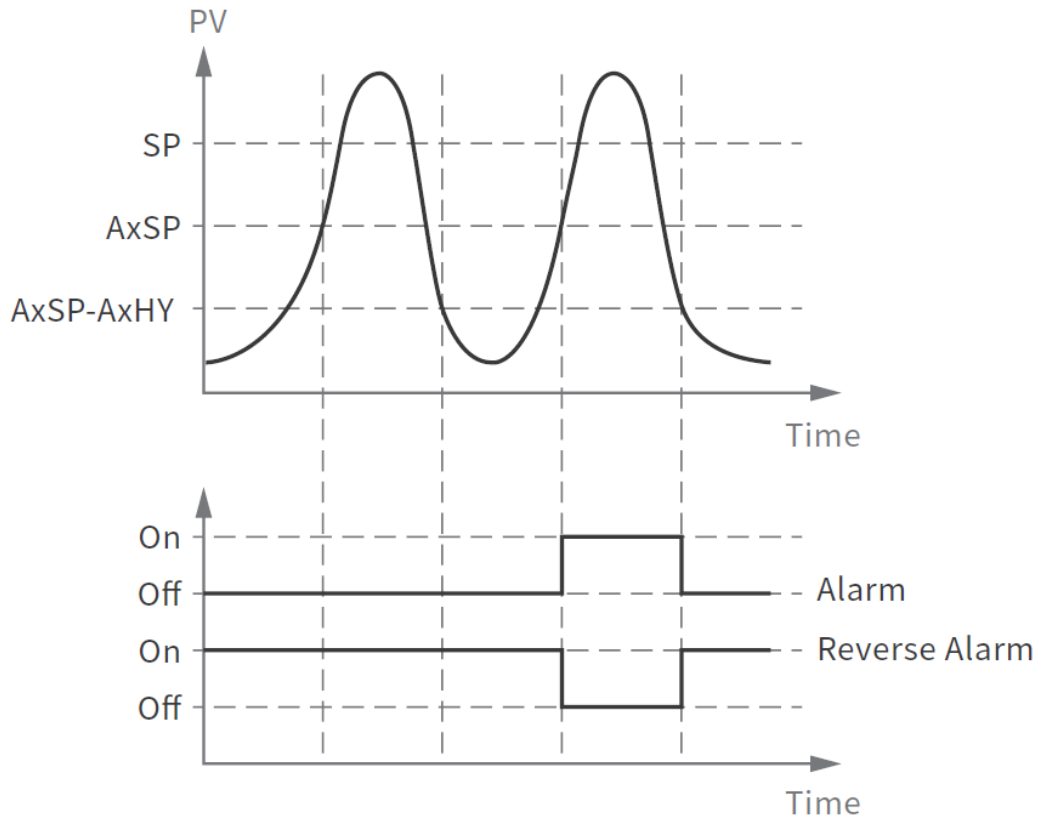

**3-19 Process Value High- Holding Alarm**

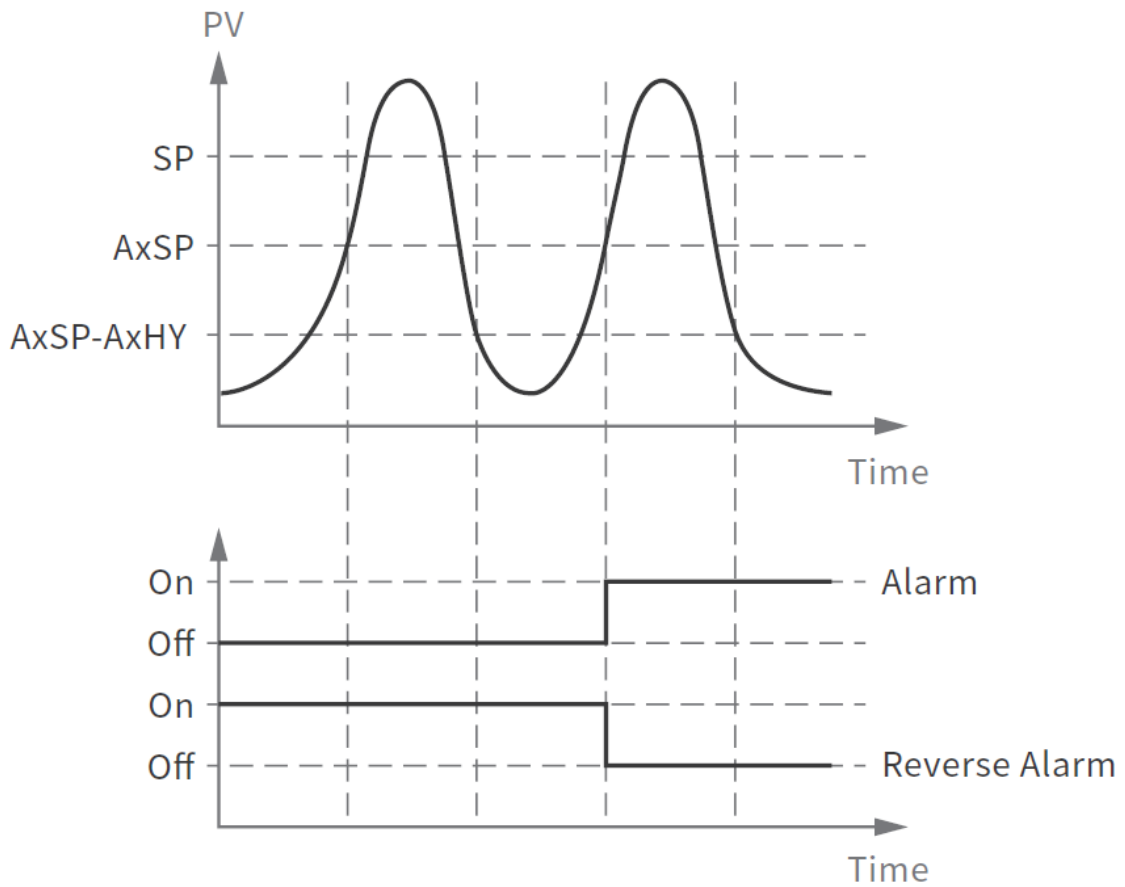

**3-20 Process Value High- Latching & Holding Alarm**

**3.5.3 Alarm Delay**

In certain applications during startup, nuisance alarms will be generated before the process value reaches the set point. To avoid these kinds of nuisance alarms, a time delay for alarms is available. To enable the time delay for alarms, set the delay time using the A1DL, A2DL, A3DL, and A4DL parameters. These parameters will avoid the nuisance alarm during the process value reaches the setpoint.

For example, the process setpoint set to 100. When the process approaching 100 it will go to 103 and 97. During this time the Hi Alarm will be activated and deactivated continuously. To avoid these kinds of nuisance alarms the alarm delay function can be used. It will generate the alarm after the PV is in alarm condition continuously at least for the period configured in alarm delay parameters. The alarm delay can be configured in minutes and seconds.

### 3.5.4 Alarm Failure Transfer

Alarm Failure transfer is activated as the unit enters failure mode. The respective Alarm will go on if ON is set for A1FT, A2FT, A3FT or A4FT and will go off if OFF is set for A1FT, A2FT, A3FT, or A4FT. The unit will enter failure mode if a sensor break occurs or if the A-D converter fails.

## 3.6 User Select Menu Configuration

Conventional controllers are designed with parameters in a fixed order. If the user needs a friendlier menu operation to suit their application, most conventional controllers do not offer a solution. The C series controllers have the flexibility for the user to select those parameters which are most significant and put these parameters in an easy access USER menu.

There are eight user-friendly parameters from the below list that can be set for user select menu configuration using the SEL1-SEL8 parameters.

1. SP2
2. DTMR
3. DISP
4. Pb
5. Td
6. TI
7. o1HY
8. CPb
9. dB
10. A1HY
11. A1SP
12. A1dV
13. A2HY
14. A2SP
15. A2dV
16. A3HY
17. A3SP
18. A3dV
19. A4HY
20. A4SP
21. A4dV
22. PL1L
23. PL1H
24. PL2L
25. PL2H
26. OFTL
27. OFTH
28. CALO

- 29. CAHI
- 30. A1DL
- 31. A2DL
- 32. A3DL
- 33. A4DL
- 34. UNIT

When using the up-down key to select parameters, all of the above parameters may not be available. The number of visible parameters is dependent on the setup configuration.

**Example:**

OUT2 is set to DE. LO, PB = 100.0, SEL1 is set to A1SP, SEL2 is set to A2SP, SEL3 is set to PB, SEL4 is set to TI, SEL5~SEL8 is set to NONE. Now, the USER menu display appears as below.

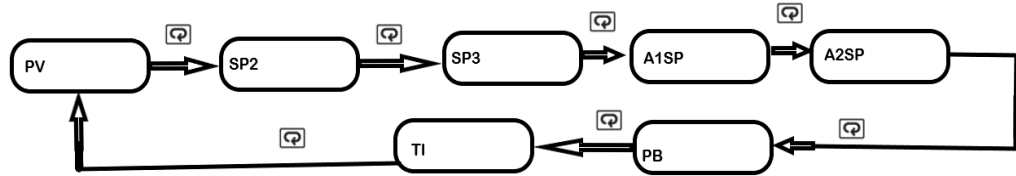

**3-21 Configurable User Menu**

### 3.7 Ramp

The ramping function is performed during power up as well as any time the setpoint is changed. Choose MINR or HRR for the RAMP setting, and the controller will perform the ramping function. The ramp rate is programmed by adjusting the RR setting. The ramping function is disabled as soon as the Failure mode, the Manual control mode, the Auto-Tuning mode or the Calibration mode occur. The ramping function is enabled whenever the event input configured to change the setpoint is triggered. The ramping function will be ramped up or down to SP1 when the event input is disabled.

#### 3.7.1 Example of Ramp without Dwell Timer

Select MINR for RAMP, set °C for UNIT, set 1-DP for DP, Set RR= 10.0, SV is set to 200°C initially and changed to 100°C after 30 minutes from power-up. The starting temperature is 30°C. After power-up, the process is running like the curve shown below.

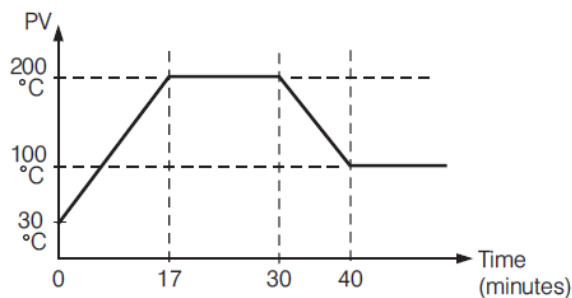

**3-22 Ramp Function**

**Note:** When the ramp function is used, the lower display will show the current ramping value. However, it will revert to show the setpoint value as soon as the up or down key is touched for adjustment. The ramp rate is initiated at power on and/or when the Setpoint is changed. Setting the RR set to zero means no ramping function at all.

### 3.8 Dwell Timer

The dwell timer can be with or without a Ramp. Alarm outputs can be configured as dwell timers by selecting dtMR for A1FN. If A1FN is set to dtMR, Alarm 1 will act as a dwell timer. Similarly, Alarm 2, Alarm3 and Alarm4 will act as dwell timers if A2FN, A3FN, or A4FN is set to dtMR. When the dwell timer is configured, the parameter DTMR is used for dwell time adjustment. The dwell time is measured in minutes ranging from 0.0 to 4553.6 minutes. The Timer starts to count as soon as the Process Value (PV) reaches its set point (SV), and triggers an alarm output once the time has elapsed. The dwell timer operation is shown in the following diagram.

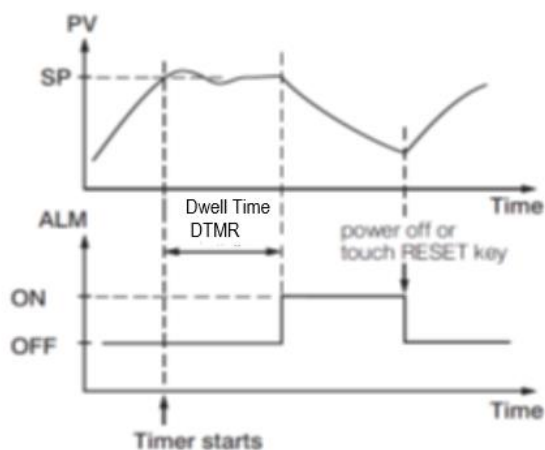

**3-23 Dwell Timer**

After the timer has finished, the dwell timer can be restarted by pressing the RESET key. The timer stops counting during manual control mode, failure mode, calibration and Auto-Tuning.

If alarm1 is configured as a dwell timer, A1MD needs to be NoRM, and Even Input can't reset DTMR (only can be reset by the Reset key  on the front panel)

### 3.9 User Calibration

Each unit is calibrated in the factory before shipment. The user can still modify the calibration in the field.

The basic calibration of the controller is highly stable and set for life. User calibration allows the user to offset the permanent factory calibration to:

- ❖ Calibrate the controller to meet a user reference standard.
- ❖ Match the calibration of the controller to that of a particular transducer or sensor input.
- ❖ Calibrate the controller to suit the characteristics of a particular installation.
- ❖ Remove long term drift in the factory set calibration.

There are two parameters: Offset Low (OFTL) and Offset High (OFTH) for adjustment to correct an error in the process value. There are two parameters for the sensor input. These two signal values are CALO and CAHI. The input signal low and high values are to be entered in the CALO and CAHI parameters respectively.

Connect the input with low scale operating temperature (For Example 0.0). Enter the low scale operating temperature in CALO. For example, 0.0. Then monitor the PV. If PV ≠ CALO, adjust the OFTL to make PV=CALO.

Connect the input with high scale operating temperature (For Example 700.0). Enter the high scale operating temperature in CAHI. For example, 700.0. Then monitor the PV. If  $PV \neq CAHI$  adjust the OFTH to make  $PV=CAHI$ .

As shown below, the two points OFTL and OFTH construct a straight line. For accuracy, it is best to calibrate with the two points as far apart as possible. After the user calibration is complete, the input type will be stored in the memory. If the input type is changed, a calibration error will occur and an error code *CAEr* is displayed.

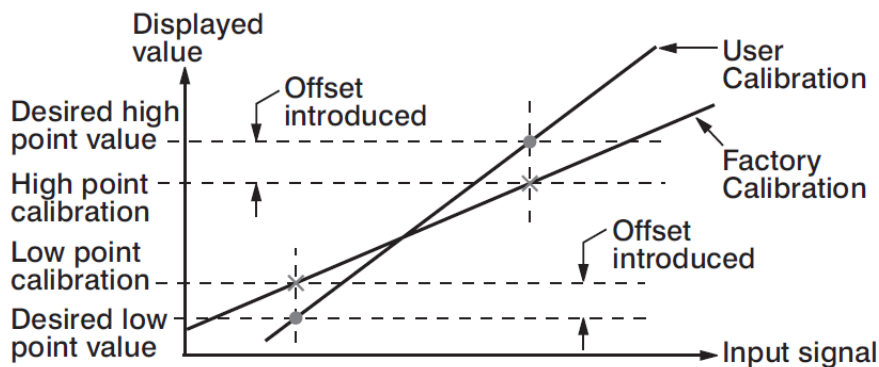

**3-24 Two Point User Calibration**

### 3.10 Digital Filter

In certain applications, the process value is too unstable to be read. To improve this, a programmable low pass filter incorporated in the controller can be used. This is a first-order filter with a time constant specified by the FILT parameter. A value of 0.5 seconds is used as a factory default. Adjust FILT to change the time constant from 0 to 60 seconds. 0 seconds represents no filter applied to the input signal. The filter is characterized by the following diagram.

#### Note

The Filter is available only for the process value (PV) and is performed for the displayed value only. The controller is designed to use an unfiltered signal for control even when a filter is applied. If a lagged (filtered) signal is used for control; it may produce an unstable process.

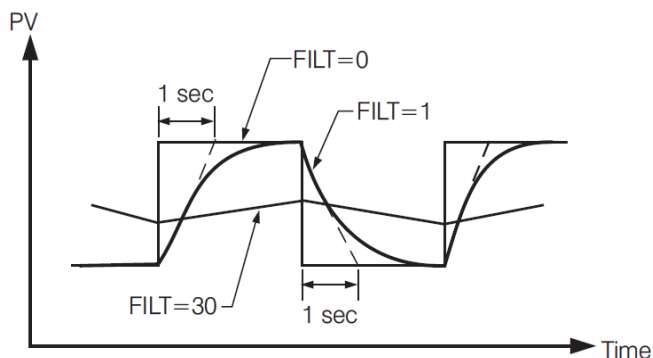

**3-25 Filter Characteristics**

### 3.11 Failure Transfer

The controller will enter failure mode if one of the following conditions occurs.

1. An SBER error occurs due to an input sensor break, an input current below 1mA for 4-20mA, or an input voltage below 0.25V for 1-5 V.
2. An ADER error occurs due to the A-D converter of the controller fails.

Output 1 and Output 2 will perform the failure transfer (O1. ft & O2. ft) function as the controller enters failure mode.

### 3.11.1 Output 1 Failure Transfer

If Output 1 Failure Transfer is activated, it will perform as follows:

1. If output 1 is configured as proportional control (PB≠0), and BPLS is selected for O1FT, then output 1 will perform a Bumpless transfer. After that, the previous average value of MV1 will be used for controlling output 1.
2. If output 1 is configured as proportional control (PB≠0), and a value of 0 to 100.0 % is set for O1FT, then output 1 will perform failure transfer. After that, the value of O1FT will be used for controlling output 1.
3. If output 1 is configured as ON-OFF control (PB=0), then output 1 will transfer to an off state if OFF is set for O1FT, and transfer to on state if ON is set for O1FT.

### 3.11.2 Output 2 Failure Transfer

If Output 2 Failure Transfer is activated, it will perform as follows:

1. If OUT2 is configured as COOL, and BPLS is selected for O2FT, then output 2 will perform a Bumpless transfer. After that, the previous average value of MV2 will be used for controlling output 2.
2. If OUT2 is configured as COOL, and a value of 0 to 100.0 % is set for O2FT, then output 2 will perform a failure transfer. After that, the value of O2FT will be used for controlling output 2.
3. If OUT2 is configured as an alarm function, and OFF is set for O2FT, then output 2 will transfer to an off state, otherwise, output 2 will transfer to an ON state if ON is set for O2FT.

### 3.11.3 Alarm Failure Transfer

An alarm failure transfer is activated as the controller enters failure mode. After that, the alarm output will transfer to the ON or OFF state which is determined by the set value of A1FT, A2FT, A3FT, and A4FT.



## 3.12 Auto-Tuning

 The Auto-Tuning process will be performed at the setpoint (SP1). The process will oscillate around the setpoint during the tuning process. Set a set point to a lower value if overshooting beyond the normal process value will cause damage. It is usually best to perform Auto-Tuning at the Setpoint the machine is expected to be operated at, with the process running normally (i.e. material in the oven, etc.)

Auto-Tuning is generally applied in the following cases:

- ❖ Initial setup for a new process
- ❖ The setpoint is changed substantially from the previous Setpoint when Auto-Tuning was performed.
- ❖ The control result is unsatisfactory

### 3.12.1 Auto-Tuning Operation Steps

1. The system has been installed normally.
2. Do not use a zero value for PB or TI; otherwise, the Auto-Tuning program will be disabled.
3. The LOCK parameter should be set to NONE.
4. Set the setpoint to a normal operating value or a lower value if overshooting beyond the normal process value will cause damage.
5. Press and hold the  key until  appear on the upper display, then let go.
6. Press and hold the  key for at least 5 seconds. The TUNE indicator will begin to flash, and the Auto-Tuning process has begun.

**NOTE:**

If the ramping function is used, it will be disabled once Auto-Tuning is started. The Auto-Tuning mode is disabled if either a failure mode or manual control mode occurs.

**Procedures:**

Auto-Tuning can be applied either as the process is warming up (Cold Start) or as the process has been in a steady-state (Warm Start). After the Auto-Tuning process is completed, the TUNE indicator will stop flashing and the unit will revert to PID control by using its new PID values. The PID values obtained are stored in non-volatile memory.

**3.12.2 Auto-Tuning Error**

If Auto-Tuning fails, an ATER AtEr message will appear on the upper display in any of the following cases.

- ❖ If PB exceeds 9000 (9000 PU, 900.0°F or 500.0°C)
- ❖ If TI exceeds 1000 seconds
- ❖ If the setpoint is changed during the Auto-Tuning process

**3.12.3 Solution for Auto-Tuning Error**

1. Try Auto-Tuning once again.
2. Do not change the setpoint value during the Auto-Tuning process.
3. Do not set zero value for PB and TI.
4. Use manual tuning
5. Touch RESET R key to reset the AtEr message.

**3.13 Manual Tuning**

In certain applications (very few), using Auto-Tuning to tune a process may be inadequate for the control requirement. In this case, the user can try manual tuning.

If the control performance by using Auto-Tuning is still unsatisfactory, the following guidelines can be applied for further adjustment of PID values.

ADJUSTMENT SEQUENCE	SYMPTOM	SOLUTION
Proportional Band (PB)	Slow Response	Decrease PB
	High overshoot or Oscillations	Increase PB
Integral Time (TI)	Slow Response	Decrease TI
	Instability or Oscillations	Increase TI
Derivative Time (TD)	Slow Response or Oscillations	Decrease TD
	High Overshoot	Increase TD

**3-3 PID Parameter Adjustment Guide****3.14 Manual Control**

To enable manual control, ensure the LOCK parameter is set to NONE. Press and hold ☐ for 6.2 seconds or until Hand ---- (Hand Control) appear on the display. Press and hold ☐ for 5 seconds or until the MANU indicator begin to flash. The lower display will show H---. The controller has now entered manual control mode. H--- Indicates the output control variable for output 1, and L--- indicates the control variable for output 2. The user can use the up-down keys to adjust the percentage values for the heating or cooling output. This % value is based on the CYC1 and CYC2 settings, where the associated output will stay on for the % of time the CYC1 & CYC2 values are set for.

The controller performs open-loop control as long as it stays in manual control mode. The manual mode menu can be reached by pressing ▼☐ keys also



### 3.14.1 Exit Manual Control

Pressing the **R** key will revert the controller to its normal display mode.

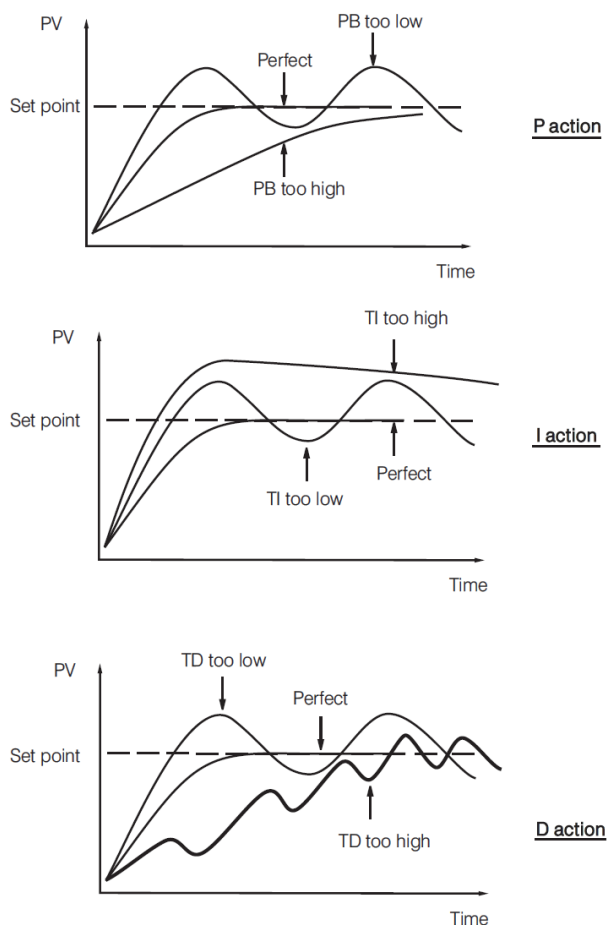

**3-26 Effects of PID Adjustment**

## 3.15 Default Setting

### 3.15.1 Factory Default Setting

The controller's parameters can be loaded with default values listed in the [parameter description table](#). In certain situation, it is desirable to retain these values after the values of the parameters have been changed. The below procedure to be followed to reload the default values.

1. Ensure the LOCK parameter is set to NONE.
2. Press and hold **[R]** for 6.2 seconds or until **Hand** **----** (Hand Control) appear on the display.
3. Press **[R]** key to navigate the manual mode menu to reach FILE.
4. Press and hold **[R]** for 5 seconds or until the upper display FILE flash for a moment.

The default values of all parameters are loaded now.







### 3.15.2 User Default Setting

The user can store the default parameter setting as per their requirement and load the stored default parameters.

#### 3.15.2.1 Store User Default Setting







The user default setting can be stored by using the below steps.

1. Ensure the LOCK parameter is set to NONE.

2. Press  and  to access the manual mode parameters. The lower display will show H0.00.
3. Press  key to navigate to File Parameter
4. Select St.US in File parameter using  or  key.
5. Press  key for 5 seconds to store the user default setting parameter. The upper display will blink a moment for the user confirmation.

### 3.15.2.2 Load User Default Setting

The stored user default setting can be loaded by using the below steps.

1. Ensure the LOCK parameter is set to NONE.
2. Press  and  to access the manual mode parameters. The lower display will show H0.00.
3. Press  key to navigate to File Parameter
4. Select Ld.US in File parameter using  or  key.
5. Press  key for 5 seconds to load the user default setting parameter. The upper display will blink a moment for the user confirmation.

## 3.16 Data Communication

The controllers support RS-485 Modbus RTU protocol for data communication. Using a PC for data communication is the most economical way. The signal is transmitted and received through the PC communication Port. Since a standard PC can't support an RS-485 port, a network adaptor such as an RS232 to RS485 Converter or USB to Serial Converter must be used to convert RS-485 to RS-232 or USB for a PC. Many RS-485 units (up to 247 units) can be connected to one RS-232 port or USB Port. Therefore, a PC with 4 comm. ports can communicate with up to 988 units. It is quite economical.

### 3.16.1 RS-485 Setup

- ❖ Enters the setup menu.
- ❖ Set the data type as signed integer or unsigned integer
- ❖ Set individual addresses for units connected to the same port.
- ❖ Set the Baud Rate (BAUD), Data Bit (DATA), Parity Bit (PARI) and Stop Bit (STOP) such that these values are accordant with PC setup conditions.

## 3.17 Retransmission

The controller can output (retransmit) PV or SP via its retransmission terminals RE+ and RE- provided that the retransmission option is ordered. A correct signal type should be selected for the option board to meet the retransmission option installed. RELO and REHI are adjusted to specify the low scale and high scale values of retransmission.

## 3.18 Heater Current Monitoring

A current transformer (CT98-1) is required to measure the heater current. The CT input signal conditioner measures the heater current when the heater is powered (output 1 is on), and the current value will remain unchanged the heater is unpowered (output 1 is off). 1 or 2 CT inputs can be connected to the controllers depending on the model. The CT1R & CT2R will indicate the heater current.

Heater break detection is enabled by enabling heater break detection setting HBEN. A **Heater break alarm (H. bK)** alerts the user when the current measured by CT1 in CT1R is lower than HB1T or CT2 in CT2R is lower than HB2T. When the current measured by CT1 in CT1R is higher than HB1T+HBHY and CT2 in CT2R is higher than HB2T+HBHY, the heater break alarm will be off. The Heater break alarm will be off when both CT values are in the normal range. The Heater break alarm function will be enabled when OUT1 is in on condition.

Heater short detection is enabled by enabling heater short detection setting HSEN. A **Heater short alarm (H. St)** alerts the user when the current measured by CT1 in CT1R is higher than HS1T or CT2 in CT2R is higher than HS2T. When the current measured by CT1 in CT1R is lower than HS1T-HSHY and CT2 in CT2R is lower than HS2T-HSHY, the heater short alarm will be off. The Heater short alarm will be off when both CT values are in the normal range. The Heater short alarm function will be enabled when OUT1 is in off condition.

**Accessory Installed**

CT98-1

**Required Setup Parameters**

**Heater Break**



1. HBEN
2. HBHY
3. HB1T
4. HB2T

**Heater Short**

1. HSEN
2. HSHY
3. HS1T
4. HS2T

**3.19 Operation Mode**

The operation mode will allow the the users to choose the operation mode of the controllers as RUN or OFF. Run mode will activate the normal PID running mode.OFF mode will disable all outputs.

Press   keys together more than 3 seconds will access the operation mode. Press  key for 3 seconds to activate the selected mode.

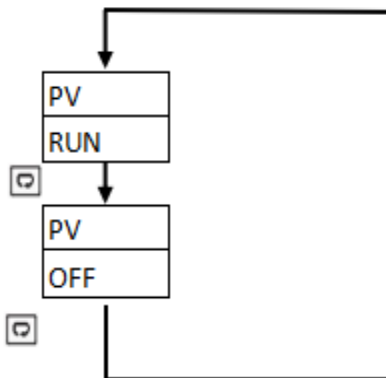

**3-27 Operation Mode**

**3.20 Event Input**

There are 6 or 2 or 1 Event Inputs that are available in this series of controllers depending on the size of the controller. Refer [section 2.9](#) for wiring an event input. The Event input accepts a digital (on/off) type signal.

Types of signals that can be used to switch the event input as below.

- ❖ Relay
- ❖ Switch contacts
- ❖ Open collector Pull Low
- ❖ TTL logic level

One of the below functions can be chosen by using **EIFN1 through EIFN6** contained in the setup menu. The same function cannot be set to more than one event input.

**Note:** The controller must have the respective event input on the controller hardware to select any of the below event input function other than NoNE in E1FN to E6FN. Otherwise the controller may malfunction.

### 3.20.1 Event Input Functions

1. NONE
2. SP2
3. RS. A1
4. RS. A2
5. RS. A3
6. RS. A4
7. RS.AO
8. CA. LH
9. D.O1
10. D.O2
11. D.O1.2
12. LOCK
13. AU.MA
14. F.tra
15. AL. oN
16. StAR: Run profile as RUN=STAR
17. CoNt: Run profile as RUN=CONT
18. PV: Run profile as RUN=PV
19. Hold: Run profile as RUN=HOLD
20. StoP: Run profile as RUN=STOP
21. d.R.SP: Operation Mode RUN/OFF

**NONE:** No Event input function. If chosen, the event input function is disabled. The controller will use PB, TI and TD for PID control and SP1 for the set point.

**SP2:** If chosen, the SP2 will replace the role of SP1 for control.

**RS. A1:** Reset Alarm 1 as the event input is activated. However, if the alarm condition still exists, the alarm will remain on even though the event input is triggered.

**RS. A2:** Reset Alarm 2 as the event input is activated. However, if the alarm condition still exists, the alarm will remain on even though the event input is triggered.

**RS. A3:** Reset Alarm 3 as the event input is activated. However, if the alarm condition still exists, the alarm will remain on even though the event input is triggered.

**RS. A4:** Reset Alarm 4 as the event input is activated. However, if the alarm condition still exists, the alarm will remain on even though the event input is triggered.

**RS.AO:** Reset all Alarms as the event input is activated. However, if the alarm condition still exists, the alarm will remain on even though the event input is triggered.

**CA. LH:** Cancel the latched alarm as the event input is activated. However, if the alarm condition still exists, the alarm will remain on even though the event input is triggered.

**D.O1:** Disable Output 1 as the event input is activated.

**D.O2:** Disable Output 2 as the event input is activated.

**D.O1.2:** Disable both Output 1 and Output 2.

**Note:** When any of D.O1, D.O2 or D.O1.2 is selected for EIFN, Output1 and/or Output 2 will revert to their normal conditions as soon as the event input is Released.

**LOCK:** All parameters are locked and unable to be changed (Read-only) in communication.

**AU.MA:** Switch between Auto-Tuning and manual tuning control mode.

**F.tra:** Switch to Failure Transfer Mode

**AL. oN:** If Alarm 2 or Alarm 3 set to E1.c.o or E2.c.o then EI1 or EI2 will activate Alarm Output Alarm 2 or Alarm 3.

**StAR:** Run profile as RUN=STAR  
**CoNt:** Run profile as RUN=CONT  
**PV:** Run profile as RUN=PV  
**Hold:** Run profile as RUN=HOLD  
**StoP:** Run profile as RUN=STOP  
**d.R.SP:** Switch between operation mode RUN & OFF.

### 3.21 Remote Setpoint

The Setpoint will change proportionally to the input given in the remote Setpoint input terminals. The remote Setpoint function needs the below parameters to be set properly.

1. RMSP: Exists if OFS1 and OFS2 and OFS3 are not all selected "None"
2. RINL: When Set Value is lower than SP1L, Setpoint will be limited by SP1L
3. RINH: When Set Value is higher than SP1H, Setpoint will be limited by SP1H
4. DRSP: E1FN~E6FN select d.R.SP, enable the Event Input controlling Remote Setpoint.

**Note:** Remote Setpoint Input needs to be calibrated properly before use Remote setpoint application. The procedure to calibrate Remote Setpoint input is explained in [section 5.1.1.7](#).

### 3.22 Ramp and Soak Program

The new C Series controller with a profile option can be used in the application where the setpoint should be changed automatically with the time. It provides 1 program with 16 segment or 2 programs with each 8 segments or 4 programs with each 4 segments. Each segment has both a ramp and soak function.

The following parameters are used to configure the controller for ramp and soak programs.

1. PROF
2. RUN
3. RMPU
4. STAR
5. END
6. PFR
7. HBLO
8. HBHI
9. HBT
10. CYC

The profile parameters can't be modified when the profile is running.

#### 3.22.1 PROF

Select the required segments to run. There are 8 options available for the user to select the profile segments.

1. **NoNE:** Not used
2. **1--4:** Uses steps 1 to 4
3. **5--8:** Uses steps 5 to 8
4. **1--8:** Uses steps 1 to 8
5. **9-12:** Uses steps 9 to 12
6. **1316:** Uses steps 13 to 16
7. **9-16:** Uses steps 9 to 16
8. **1-16:** Uses steps 1 to 16

#### 3.22.2 RUN

Select the profile run mode. There are 5 modes available in the controller.

1. **StAR**: Start to run profile
2. **CoNt**: Continue run profile
3. **PV**: Continue run profile from current PV
4. **Hold**: Hold profile
5. **SToP**: Stop profile

#### **3.22.2.1 StAR**

The Profile starts to run from the first segment in the selected profile. In run mode, the profiler varies the set point according to the stored profile values.

#### **3.22.2.2 CoNt**

The Profile starts to run from the segment where it stopped.

#### **3.22.2.3 PV**

The Profile starts to run from the segment where it stopped with current process value.

#### **3.22.2.4 Hold**

In hold mode, the profile is frozen at its current point. In this state, the user can make temporary changes to any profile parameter (for example, a target setpoint, dwell time or the time remaining in the current segment). Such changes will only remain effective until the profile is reset and run again and when they will be overwritten by the stored profile values.

#### **3.22.2.5 StoP**

In stop mode, the Profile is stopped.

### **3.22.3 RMPU**

Select the Ramp and Soak time units to be used. The options available for selection are Hour Minutes (HH: MM) and Minute Seconds (MM: SS)

### **3.22.4 STAR**

The Setpoint value of the profile start. The options available for selection is Process value (PV) and controller Setpoint (SP1).

The normal method is to start the profile from the process value because this will produce a smooth and Bumpless start to the process. However, to guarantee the time of the first segment, the STAR set to SP1 for the start point

### **3.22.5 END**

The Setpoint value at the end of the profile. The options available for end Setpoint is Controller Setpoint (SP1). The Alarm output configured with **PF. Ed** will be on at the end of the profile.

#### **3.22.5.1 SP1**

The Profile ends with controller Setpoint SP1.

### **3.22.6 PFR**

If power is lost and then restored, while a profile is running, the behaviour of the profile is determined by the setting of the parameter "PFR" "power fail recovery in the profile configuration. The options available for **PFR** are **CONT, PV, SP1**.

#### **3.22.6.1 CONT**

If **CONT** is selected, then when power is restored the profile continues from where it was interrupted when power was lost. The parameters such as setpoint value (SV), time remaining (TIMR) and cycle remaining (CYCR) will be restored to their power-down values. For applications that need to bring the process value to the setpoint value as soon as possible, this is the best choice. The two diagrams below illustrate the respective responses.

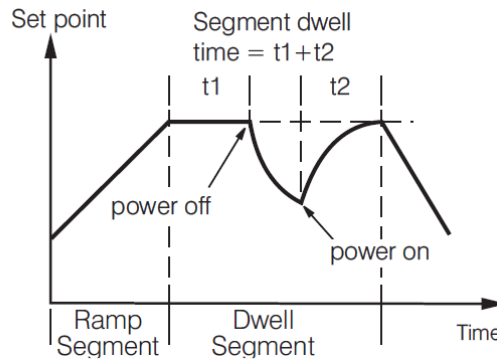

**3-28 Power failure recovery from the profile at Dwell segment**

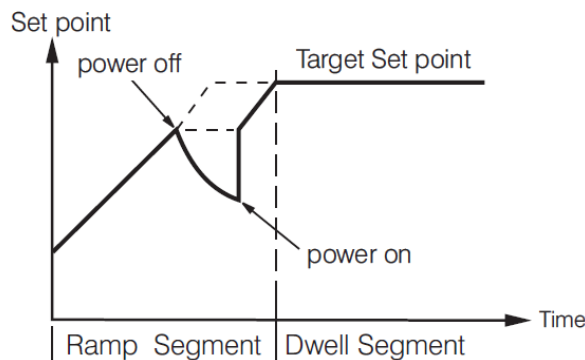

**3-29 Power failure recovery from the profile at Ramp segment**

### 3.22.6.2 PV

If **PV** is selected then when power is restored the setpoint starts at the current process value, and then runs to the target setpoint of the active segment. This choice provides a smoother recovery. The two diagrams below illustrate the respective responses

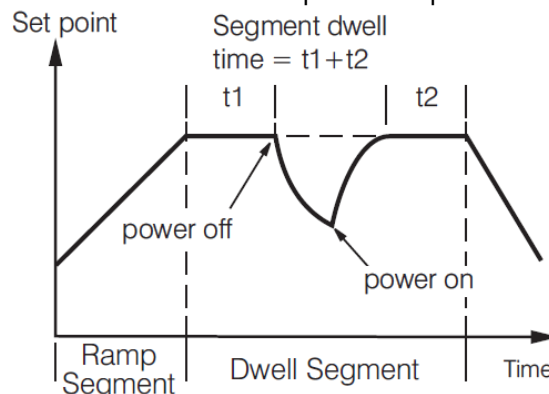

**3-30 Power failure recovery from PV at Dwell segment**

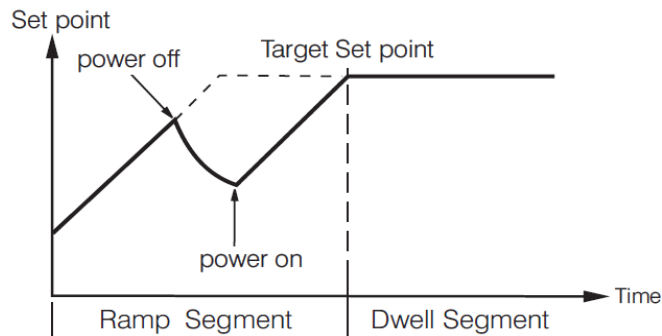

### 3-31 Power failure recovery from PV at Ramp Segment

#### 3.22.6.3 SP1

If SP1 If is selected, then when power is restored the profiler is disabled and it enters static mode, and SP1 is selected for control set point.

#### 3.22.7 Holdback

As the set point ramps up or down (or dwells), the measured value may lag or deviate from the setpoint by an undesirable amount. "Holdback" is available to freeze the profile at its current state. The action of Holdback is the same as a deviation alarm. Holdback has three parameters.

1. **HBLO**: Holdback low band
2. **HBHI**: Holdback high band
3. **HBT**: Holdback wait time

If the error from the setpoint exceeds the set **holdback high band (HBHI)** or lags than the set **holdback low band (HBLO)**, then the holdback will automatically freeze the profile at its current point and the holdback timer begins to count and an alarm configured with **PF. Hb** will on. When the value of the holdback timer exceeds the value of **holdback wait time (HBT)**, the profiler will no longer be freeze and jump to its next segment, at the same time an error code **Hb. Er** will be displayed. The holdback time can be configured in Hour: Minute unit only.

#### 3.22.8 CYC

The number of cycles to be repeated for the selected profile to be configured by this parameter.

#### 3.22.9 Running, Holding and Stopping a Profile

The profile has been started by selecting RUN in the upper display using key then select the starting setpoint for the profile in the lower display by using keys. After selecting **STAR** or **CONT** or **PV**, press keys simultaneously for 1 second to start the profile. The same procedure is applied for Holding and stopping profile. To holding the profile, select **HOLD** and stop the profile select **STOP** in the lower display

#### 3.22.10 Viewing and Modifying the Profile Progress

The Profile in progress can be monitored and modified by using the four parameters as below.

1. **CYCR**: The remaining cycles of the profile
2. **STEP**: The running step of the profile
3. **TIMR**: The time remaining to complete the current step of the profile
4. **STAT**: The current state of the profile.

#### 3.22.11 Configuring the Profile



The profile has been configured by using the following parameters. There are 16 segments available for the user for the configuration. The 16 segments can be used as a single profile or two profiles with each 8 segments or four profiles with each 4 profiles. This selection can be done by **PROF** parameter selection.

### **3.22.11.1 Profile Segment Parameters**

Each profile segments have the following parameters.

1. Target Set Point(TSP)
2. Ramp Time (RPT)
3. Soak Time (SKT)

#### **3.22.11.1.1 Target Set point**

The target Setpoint of the segment can be configured by the parameters TSP1, TSP2, TSP3, TSP4, TSP5, TSP6, TSP7, TSP8, TSP9, TSPA, TSPB, TSPC, TSPD, TSPE, TSPF, and TSPG.

#### **3.22.11.1.2 Ramp Time**

The Ramp time of the segment can be configured by the parameters RPT1, RPT2, RPT3, RPT4, RPT5, RPT6, RPT7, RPT8, RPT9, RPTA, RPTB, RPTC, RPTD, RPTE, RPTF, and RPTG.

#### **3.22.11.1.3 Soak Time**

The Soak time of the segment can be configured by the parameters SKT1, SKT2, SKT3, SKT4, SKT5, SKT6, SKT7, SKT8, SKT9, SKTA, SKTB, SKTC, SKTD, SKTE, SKTF, and SKTG.

## **3.23 Transmitter Power Supply**

The controller output 2 can be configured as transmitter power supply by selecting DCPS in output and installing the necessary output module on the out2 location. The available options are 20V,20mA, 12V, 40mA, 5V, 80mA.

## 4 Applications

### 4.1 Heat Only Control with Dwell Timer

An oven is designed to dry the products at 150°C for 30 minutes, and then stay unpowered for another batch. A C Series controller equipped with a dwell timer is used for this purpose. The system diagram is shown as below.

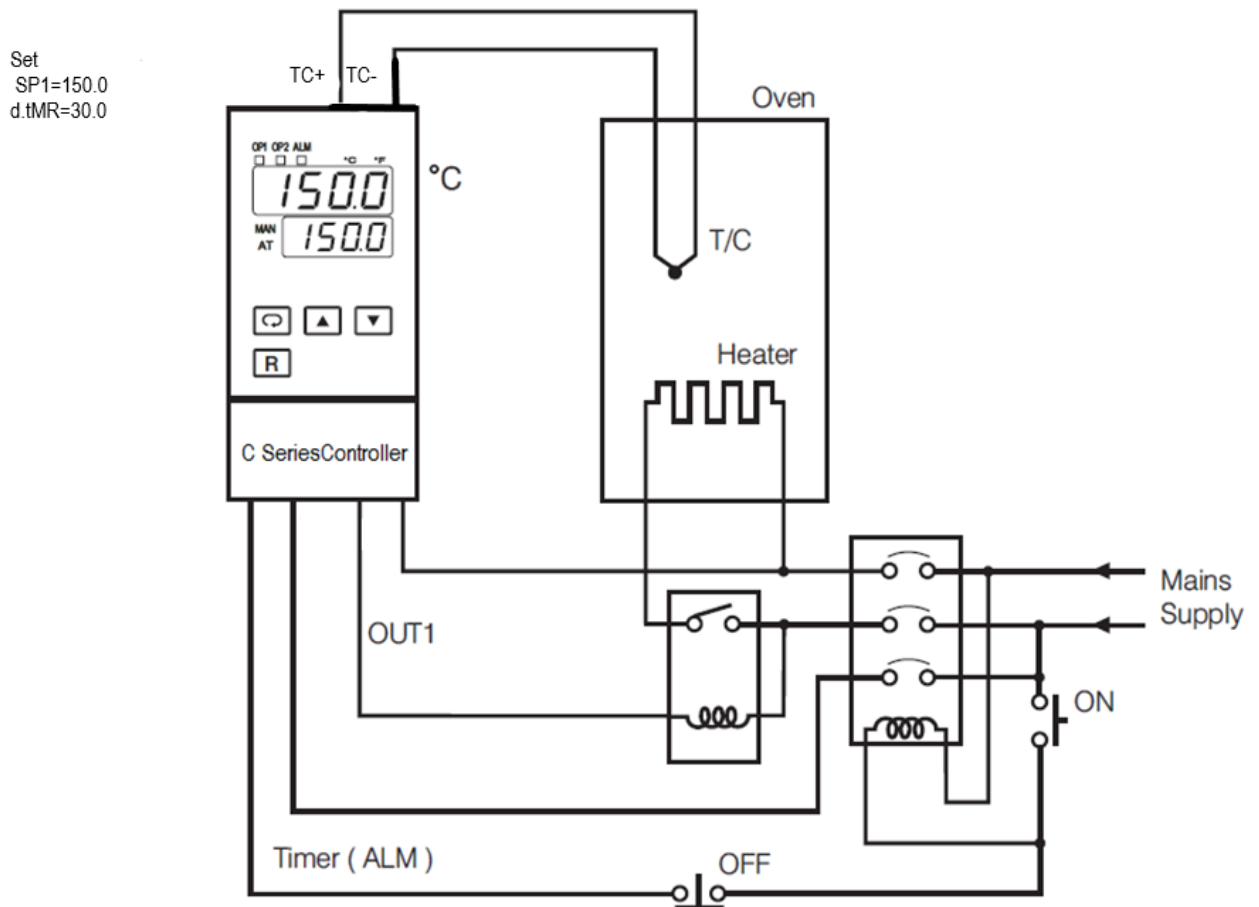

#### 4-1 Heat Only Control with Dwell Timer

To achieve this function set the following parameters in the setup menu.

INPT=K\_TC  
UNIT=° C  
DP=1\_DP  
SP1=150.0  
DTMR=30.0  
OUT1=REVR  
O1TY=RELY  
CYC1=18.0  
O1FT=BPLS  
ALFN=DTMR  
ALFT=ON

Auto-Tuning is performed at 150°C for a new oven.

## 4.2 Cool Only Control

A C Series Controller is used to control a refrigerator at a temperature below 0°C. Since the required temperature is lower than the ambient temperature, a cooling action is required. Hence, select DIRT for OUT1. Since output 1 is used to drive a magnetic contactor, O1TY is set to RELY. A small temperature oscillation is tolerable; therefore, use ON-OFF control to reduce the overall wear and cost. To achieve ON-OFF control, PB is set to zero and O1HY is set to 0.1°C.

Setup Summary:  
 INPT=PT.DN  
 UNIT= °C  
 DP=1-DP  
 OUT1=DIRT  
 O1TY=RELY

User Menu:  
 PB = 0 (°C)  
 O1HY=0.1 (°C)

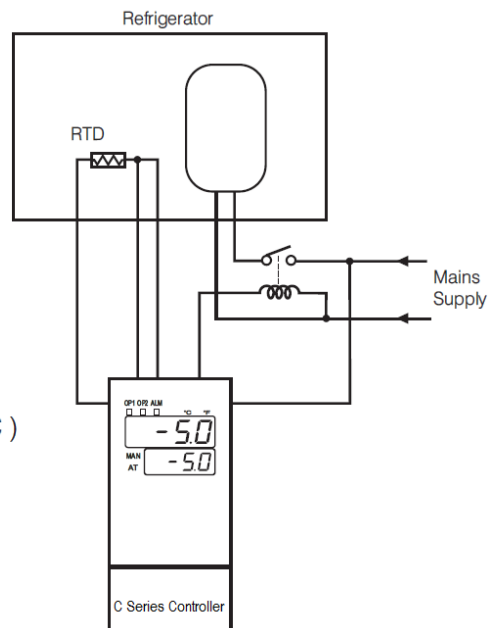

### 4-2 Cooling Control

## 4.3 Heat and Cool Control

An injection mold is required to be controlled at 120°C to ensure a consistent quality of the parts. An oil pipe is buried in the mold. Since plastic is injected at a higher temperature (e.g. 250°C), the circulation oil needs to be cooled as its temperature rises. Here is an example.

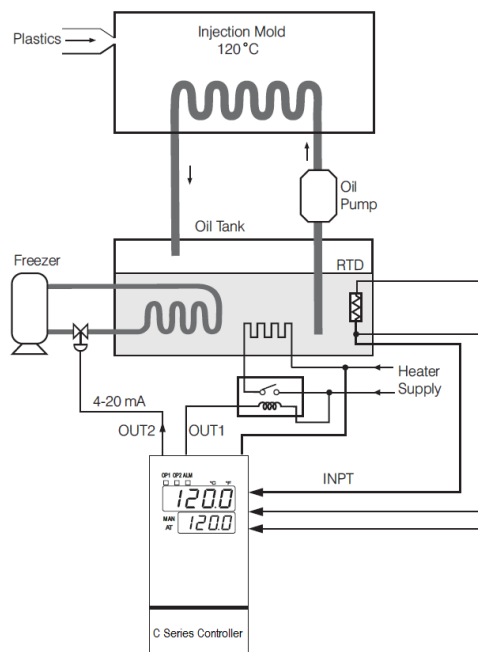

### 4-3 Heat Cool Control

The PID Heat-Cool control is used for the above example. To achieve this, set the following parameters in the Setup Menu

INPT=PT.DN  
UNIT=° C  
DP= 1-DP  
OUT1=REVR  
O1TY=RELY  
CYC1=18.0 (sec.)  
O1FT=BPLS  
OUT2=COOL  
O2TY=4-20  
O2FT=BPLS

Adjust SV at 120.0° C, CPB at 125 (%) and DB at -4.0 (%).  
Apply Auto-Tuning at 120°C for a new system to get optimal PID values.

Adjustment of CPB is related to the cooling media used. If water is used as cooling media instead of oil, the CPB is set to 250 (%). If air is used as cooling media instead of oil, the CPB is set to 100 (%). Adjustment of DB is dependent on the system requirements. A more positive value of DB will prevent an unwanted cooling action but will increase the temperature overshoot, while a more negative value of DB will achieve less temperature overshoot, but will increase unwanted cooling action.

## 4.4 Ramp & Dwell

### 4.4.1 Temperature Cycling Chamber

A chamber is used to test the temperature cycling effect on personal Computers. An external cycle timer is used to control the event input for switching the set point. The products under test are required to stay at 60°C for 1 hour and -10°C for 1 hour. The transition interval between high-low temperatures is required to be 5 minutes. Make the following setup. The ramp rate for the setpoint is 14°C/minute.

E1FN=SP2  
A1FN=DTMR  
DTMR=5.0  
OUT1=REVR, Relay Output  
OUT2=COOL, 4-20mA Output  
RAMP=MINR  
RR=14.0  
UNIT=°C  
DP=1-DP  
SP1=60.0  
SP2=-10.0

The circuit diagram and its temperature profile are shown below.

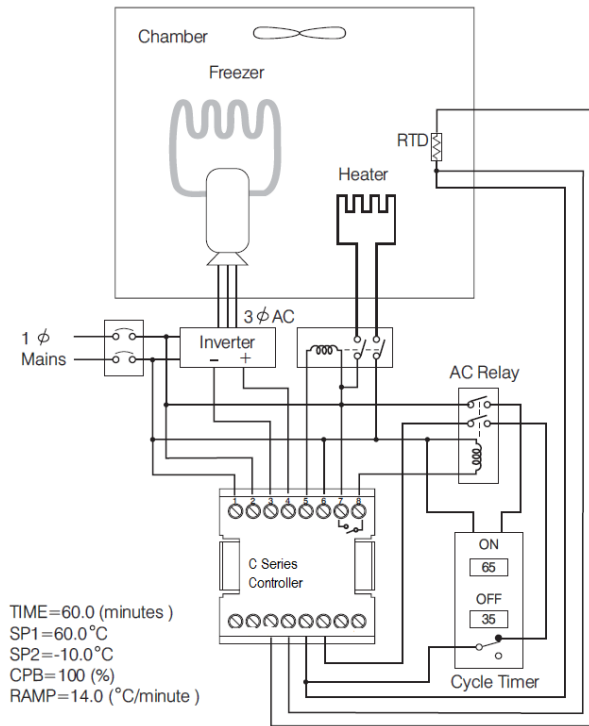

#### 4-4 Ramp & Dwell Temperature Cycling Chamber

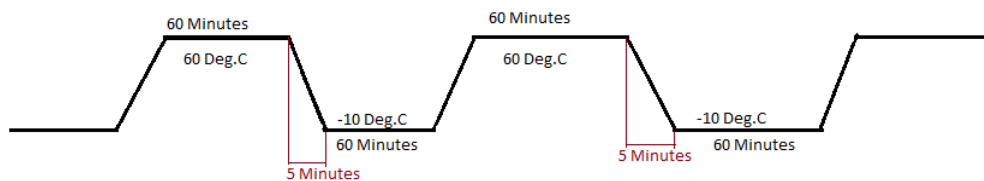

#### 4-5 Temperature Profile for Temperature Cycling Chamber

A C Series Controller provides a 4-20 mA signal to control the speed of an Inverter.

#### 4.4.2 Programmable Bread Baking Oven

Bread is baked in batches. A ramp is incorporated to control the thermal gradient to suit for making the bread. A dwell timer is used to shut off the oven power and announce to the baker. The system is configured as shown in the following diagram and configuration.

A1FN=DTMR  
 DTMR=40.0  
 OUT1=REVR, Relay Output  
 OUT2=AL1, Relay Output  
 RAMP=MINR  
 RR=30.0  
 UNIT=°C  
 DP=1-DP  
 SP1=180.0

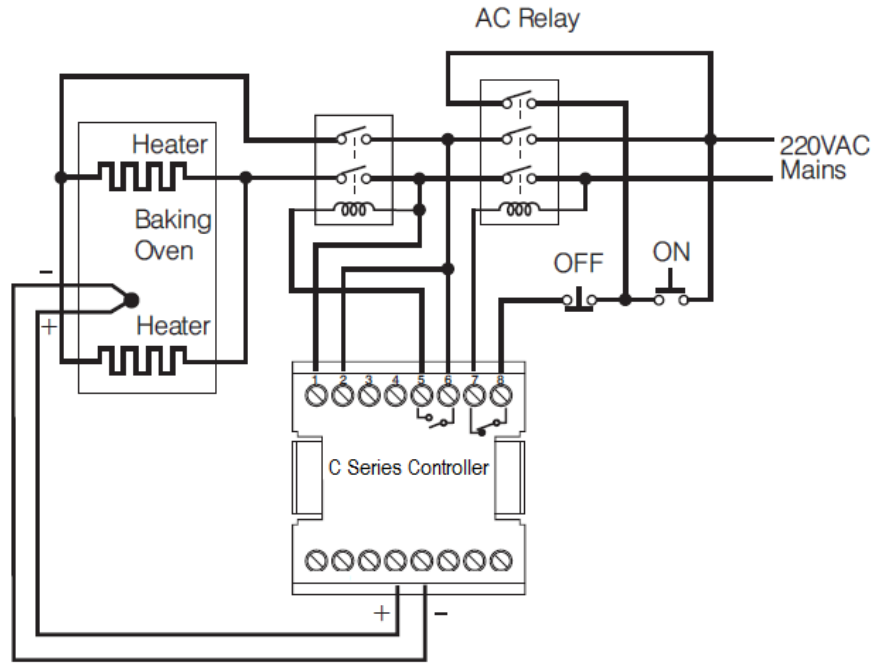

#### 4-6 Bread Baking Oven

Order a form A relay for Alarm 1. Push the ON switch to start a batch. The temperature will rise with a ramp rate determined by the RAMP value. Bread is baked with the setpoint temperature for a predetermined time which is programmed by DTMR value, and then the power is shut off. The temperature profile is shown in the following figure.

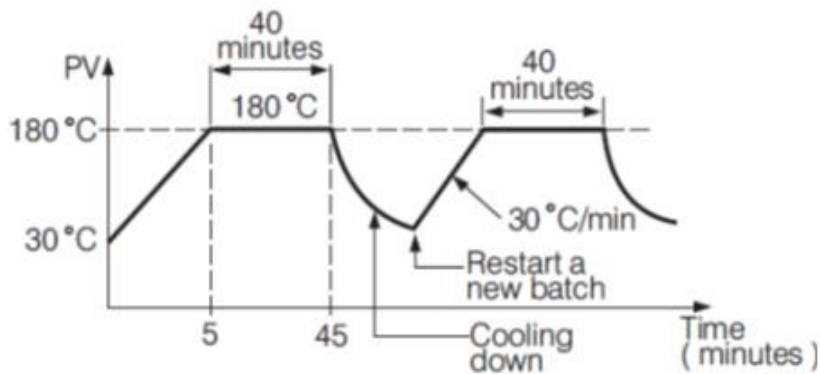

#### 4-7 Temperature Profile of Baking Oven

##### 4.5 Remote Setpoint

An on-line multiple zone oven is used to dry paint. Since heat demand varies at different positions in the production line, multiple zones with individual controls should be used to ensure a consistent temperature profile. If the user uses a C Series Controller with a retransmission output for the master controller and retransmits its setpoint to the remote Setpoint input of the slave controllers, each zone will be synchronized with the same temperature. Here is an example.

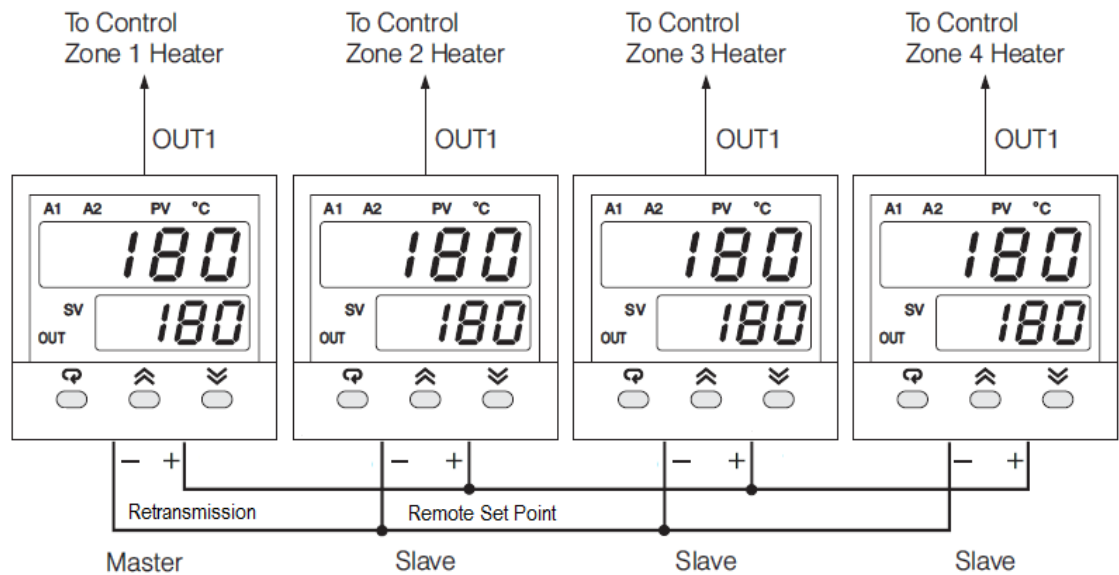

#### 4-8 Remote Setpoint Application

Set the following parameters in the setup menu.

For master unit  
 OFS3=3(0-5V)  
 RETY=RE.SP  
 RELO= 0°C  
 REHI = 300°C

For slave units  
 RMSP=2(0 – 5V)  
 RINL=0°C  
 RINH=300°C

If a voltage signal (such as in the above example) is sent to slave units, the slave inputs must be connected in parallel. If a current signal (e.g. 4-20 mA) is sent to slave units, the slave inputs must be connected in series. The current retransmission is used widely since it can transmit to a longer distance without voltage drop.

**Note:** REHI and RINH should be set with values higher than the setpoint range used.

#### 4.6 RS 485 Communication in Controller

A Tile making plant has 5 production lines. Each production line is equipped with 16 Controllers to control the temperature for the Kiln. The foreman wants to be able to program the controllers and monitor the process in the control room to improve quality and productivity. A cost-effective solution for the above application is to use 80 controllers with RS-485 communication plus a converter and PC based software for this application.

The system is installed as shown in the following diagram.

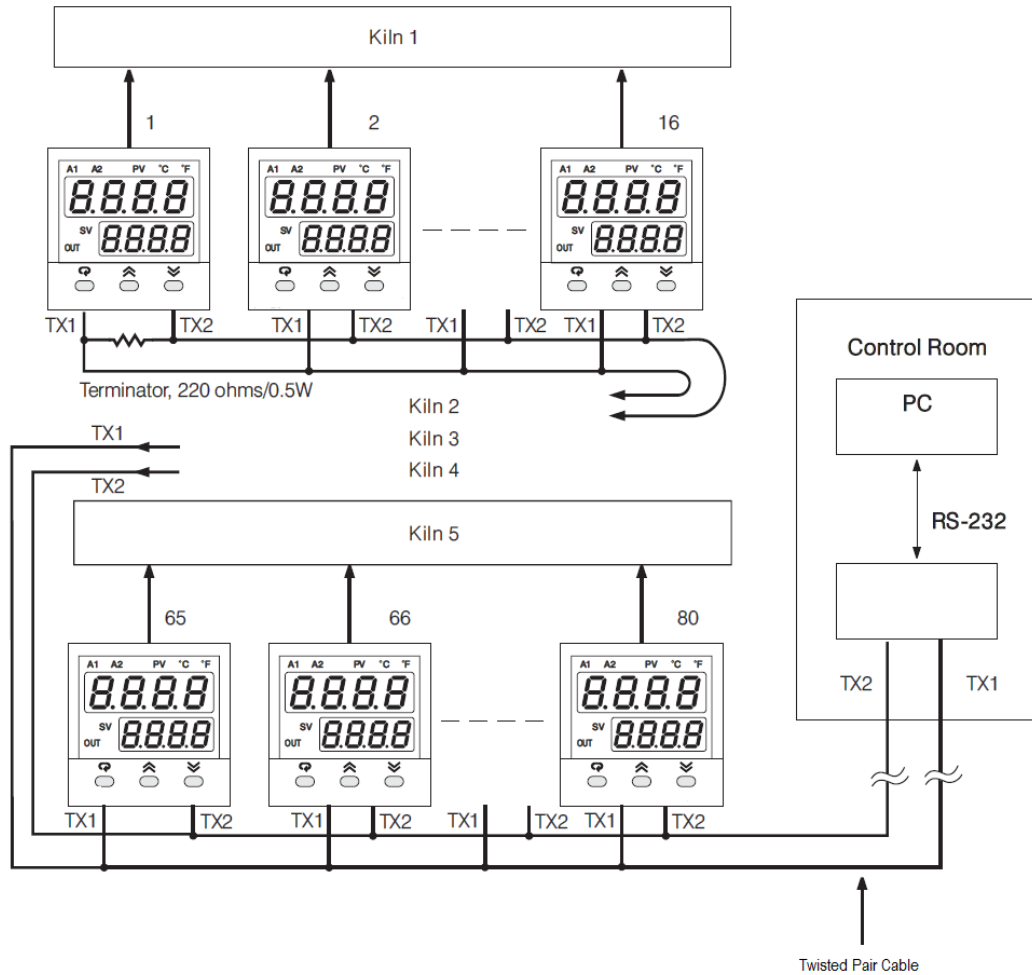

#### 4-9 RS-485 Application

#### 4.7 Retransmission Application

An air-conditioned room uses controllers to control its temperature and humidity. The temperature and humidity are required to be recorded on a recorder. The ranges of interest for these two quantities are 20°C to 30°C and 40% RH to 60% RH. The recorder inputs accept 0 - 5 V signal. To achieve this, set the following parameters in the Setup menu.

##### UNIT 1

OFS3=3(0-5V)  
 RETY=RE.PV  
 RELO= 0°C  
 REHI = 300°C  
 INPT= PTDN  
 UNIT=°C  
 DP= 1-DP

##### UNIT 2

OFS3=3(0-5V)  
 RETY=RE.PV  
 RELO= 0°C  
 REHI = 300°C  
 INPT= 0 - 1 V (According to humidity sensor)  
 UNIT= PU  
 DP= 1-DP



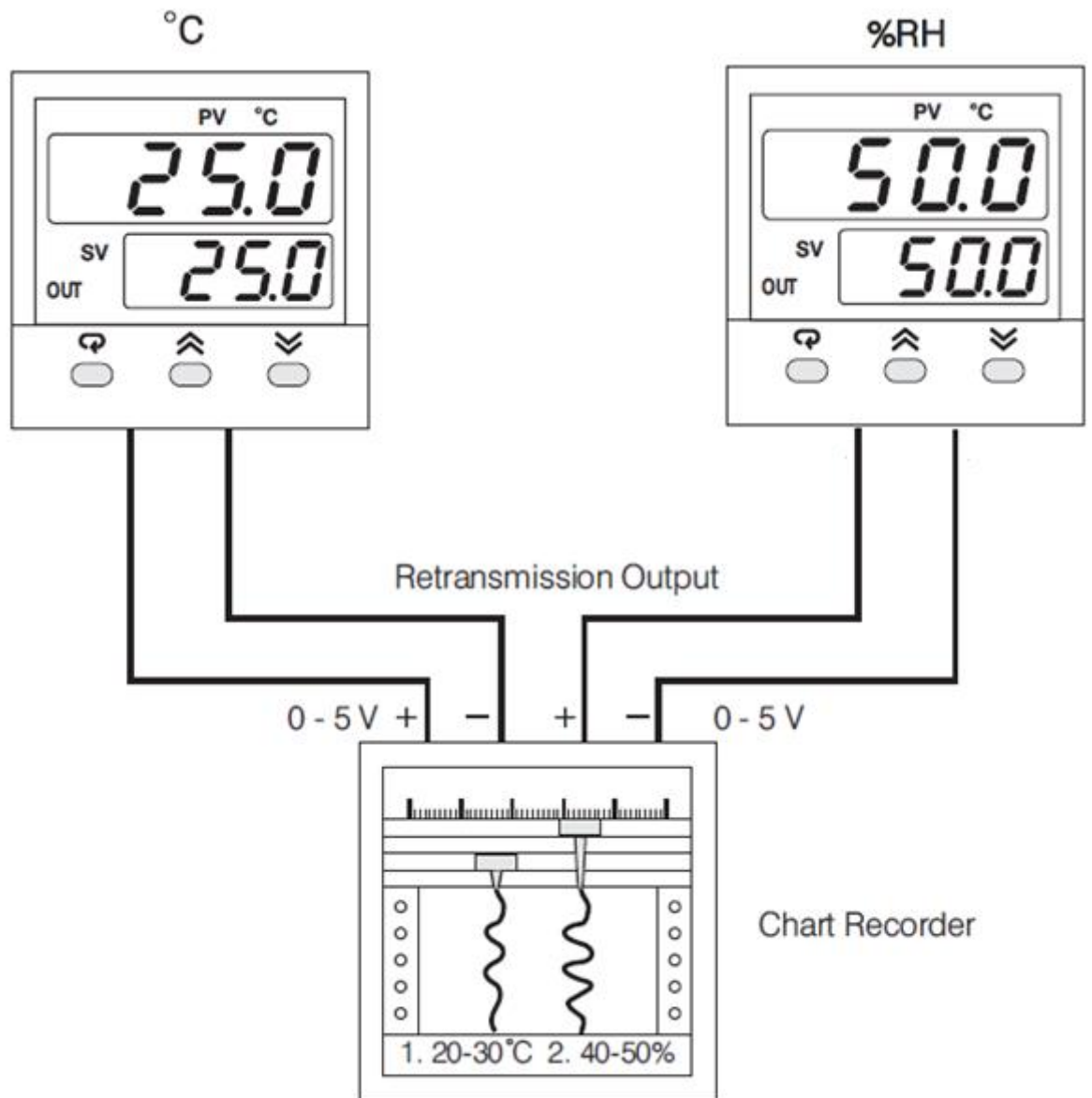

#### 4-10 Retransmission Application

#### 4.8 Ramp & Soak Profile in Heat Treatment Chamber

A heat treatment chamber needs to vary temperature as a function of time. Because the process requires a rapid increase in temperature as it is heated and a rapid decrease in temperature as it is cooled. To achieve a rapid increase in temperature, an additional heater is turned on at a higher range of temperature. A cooling fan is turned on to accelerate the cooling rate as the temperature falls fast. An alarm is required to announce the operator as the procedure is finished. Since the condition is changing when an additional heater is turned on, the PID control parameter should be different from the case of a single heater. The C Series controller with a profiling function option is perfect to meet the above requirements. The system diagram is shown below:

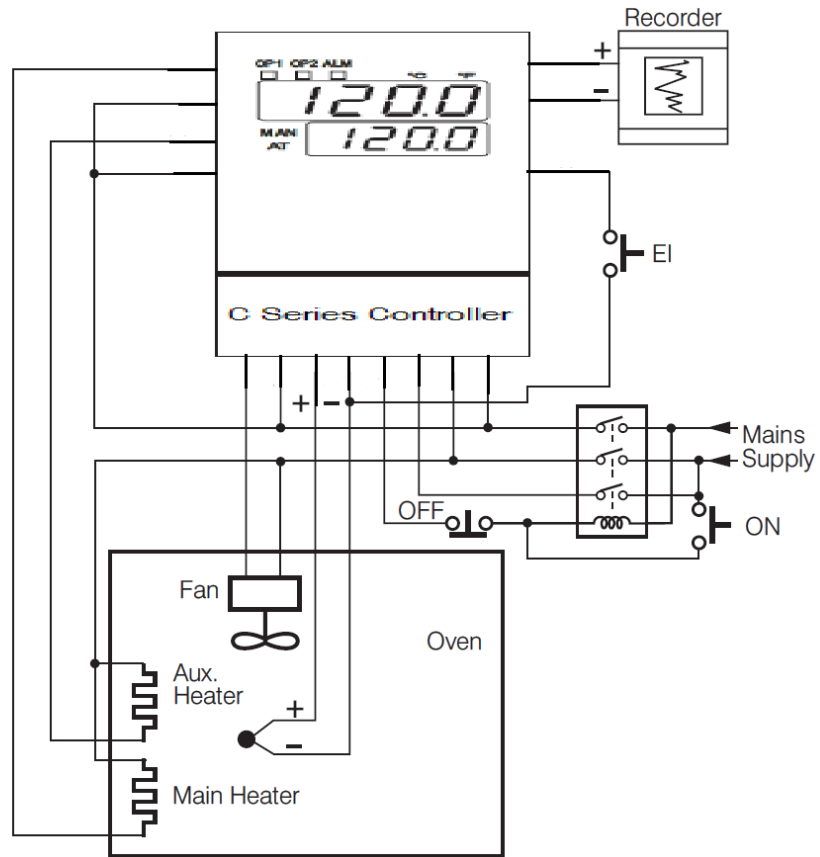

**4-11 Heat Treatment Chamber**

The output 1 is used to drive the main heater, the output 2 is used to drive the cooling fan

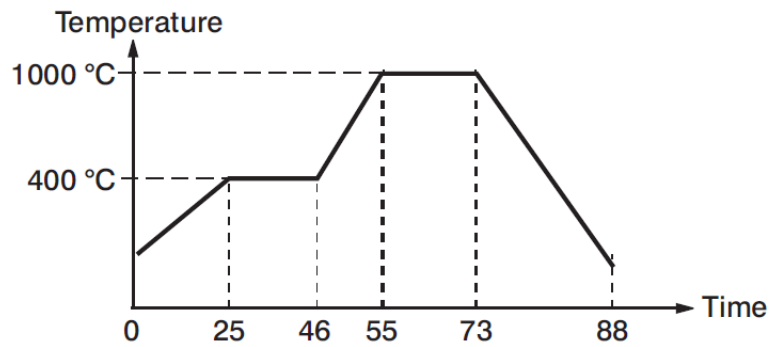

**4-12 Temperature Profile of the Heat Treatment Chamber**

The temperature profile shown in the above figure can be achieved by using the following parameters.

PROF=1-4  
 RUN=StAR  
 RMPU=MM: SS  
 STAR=PV  
 END=OFF  
 PFR=CONT  
 CYCL=1

TSP1=400°C  
 RPT1=25:00  
 SKT1=00:00

TSP2=400°C  
RPT2=00:00  
SKT2=21:00  
TSP3=1000°C  
RPT3=09:00  
SKT3=00:00  
TSP4=1000°C  
RPT4=00:00  
SKT4=18:00

INPT=K\_TC  
UNIT=°C  
DP=No dP  
OUT1=REVR  
O1FT=BPLS  
CYC1=18  
OUT2=COOL

## 5 Calibration

 Do not proceed through this section unless there is a definite need to re-calibrate the controller. All previous calibration data will be lost. Do not attempt recalibration unless you have appropriate calibration equipment. If calibration data is lost, you will need to return the controller to your supplier who may charge you a service fee to re-calibrate the controller.

 Entering the calibration mode will break the control loop. Make sure that the system is allowable to apply the calibration mode.

### 5.1 Equipment Required Before Calibration

1. A high accuracy calibrator (Fluke 5520A Calibrator recommended) with the following functions
  - ❖ 0 - 100 mV millivolt source with 0.005 % accuracy
  - ❖ 0 - 10 V voltage source with 0.005 % accuracy
  - ❖ 0 - 20 mA current source with 0.005 % accuracy
  - ❖ 0 - 300Ω resistant source with 0.005 % accuracy
2. A test chamber providing 25°C - 50°C temperature range
3. A switching network (SWU16K, optional for automatic calibration)
4. A calibration fixture equipped with programming units (optional for automatic calibration)
5. A PC installed with calibration software (optional for automatic calibration)

The calibration procedures described in the following section are step by step manual procedures. Since a controller needs 30 minutes to warm up before calibration, calibrating the units one by one is quite inefficient. An automatic calibration system for small quantity as well as for an unlimited quantity is available upon request.

#### 5.1.1 Manual Calibration Procedure

Set the Lock parameter to the unlocked condition (CODE= 0). Press and hold the scroll key until `CR.L` appears on the display, then release the scroll key. Press the scroll key for 2-3 seconds then release, the display will show `RdLo` and the unit will enter the calibration mode.

##### 5.1.1.1 Calibrate Zero of A to D Converter

Short the thermocouple input terminals (TC+, TC-) and select the input type as K type Thermocouple in the INPT parameter in bASE menu configuration. Press and hold the scroll key until `CR.L` appears on the display, then release the scroll key. Press the scroll key for 2-3 seconds then release, the display will show `RdLo` and the unit will enter the calibration mode. Then press scroll key for at least 5 seconds. The display will blink a moment and a new value is obtained. If the display didn't blink or the obtained value is equal to -199.9 or 199.9, then the calibration failed.

##### 5.1.1.2 Calibrate Gain of A to D Converter

Select the input type as K type Thermocouple in the INPT parameter in bASE menu configuration. Press and hold the scroll key until `CR.L` appears on the display, then release the scroll key. Press the scroll key for 2-3 seconds then release, the display will show `RdLo` and the unit will enter the calibration mode. Press scroll key to navigate to `RdHi`. Send a 60-mV signal to the thermocouple input terminals with the correct polarity. Press scroll key for at least 5 seconds. The display will blink a moment and a new value is obtained. If the display didn't blink or the obtained value is equal to -199.9 or 199.9, then the calibration fails.

### 5.1.1.3 Calibrate Offset of Cold Junction Compensation

Setup the equipment according to the following diagram for calibrating the cold junction compensation. Note that a K type thermocouple must be used.

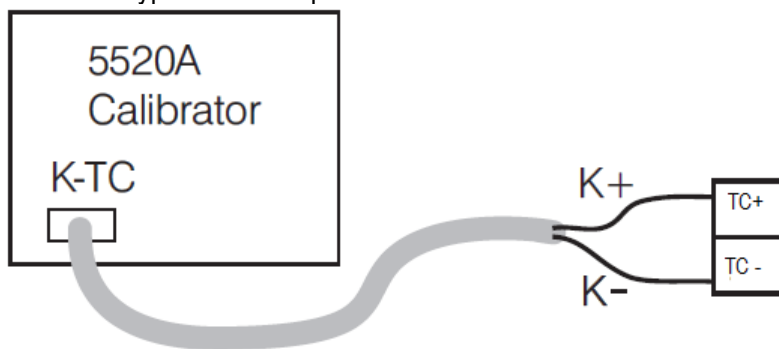

#### 5-1 Cold Junction calibration Setup

Let controller sit at least 20 minutes in a room temperature of  $25\pm 3^{\circ}\text{C}$ . The 5520A calibrator is to be configured as a K type thermocouple output with internal compensation. Send a  $0.00^{\circ}\text{C}$  signal to the controller.

Select the input type as K type Thermocouple in the INPT parameter in bASE menu configuration. Press and hold the scroll key until `[RL]` appears on the display, then release the scroll key. Press the scroll key for 2-3 seconds then release, the display will show `[AdLo]` and the unit will enter the calibration mode. Press scroll key to navigate to `[JLo]`. Press up/down key to obtain 40.00. Press the scroll key for at least 5 seconds. The display will blink a moment and a new value is obtained. If the display didn't blink or the obtained value is equal to 5.00 or 40.00, then the calibration failed.

### 5.1.1.4 Calibrate Gain of Cold Junction Compensation

Setup the equipment the same as during [Offset calibration of Cold Junction Compensation](#). The unit under calibration is to be powered in a room with a temperature of  $50\pm 3^{\circ}\text{C}$  for at least 20 minutes. The calibrator source is to be set to  $0.00^{\circ}\text{C}$  with internal compensation mode.

Select the input type as K type Thermocouple in the INPT parameter in bASE menu configuration. Press and hold the scroll key until `[RL]` appears on the display, then release the scroll key. Press the scroll key for 2-3 seconds then release, the display will show `[AdLo]` and the unit will enter the calibration mode. Press scroll key to navigate to `[JH]`. Press the scroll key for at least 5 seconds. The display will blink a moment and a new value is obtained. If the display didn't blink or the obtained value is equal to -199.9 or 199.9, then the calibration failed.

This setup is performed in a high-temperature chamber, hence it is recommended to use a computer to perform the procedures

### 5.1.1.5 Calibrate RTD Input

Select the input type as PT100 RTD in the INPT parameter in bASE menu configuration. Press and hold the scroll key until `[RL]` appears on the display, then release the scroll key. Press the scroll key for 2-3 seconds then release, the display will show `[AdLo]` and the unit will enter the calibration mode. Press scroll key to navigate to `[rtdL]`. Send a  $100\ \Omega$  signal to the RTD input terminals (PTA, PTB, PTB) according to the connection. Press the scroll key for at least 5 seconds. The display will blink a moment, otherwise, the calibration failed.

Press scroll key and the display will navigate to `[rtdH]`. Change the resistance value to  $300\ \Omega$ . Press scroll key for at least 5 seconds. The display will blink a moment and two values are obtained for RTDH and RTDL. If the display didn't blink or the obtained value is equal to -199.9 or 199.9, then the calibration failed.

### 5.1.1.6 Calibrate Linear Input

Select the input type as 0 to 10V in the INPT parameter in bASE menu configuration. Press and hold the scroll key until  $\boxed{\text{RL}}$  appears on the display, then release the scroll key. Press the scroll key for 2-3 seconds then release, the display will show  $\boxed{\text{AdLo}}$  and the unit will enter the calibration mode. Press scroll key to navigate V1L. Send a 0V signal to the V+ and V- terminals. Press scroll key for at least 5 seconds. The display will blink a moment and a new value is obtained. If the display did not blink or the obtained value is equal to -199.9 or 199.9, the calibration failed.

Press scroll key and the display will navigate to V1G. Send a 10V signal to the V+ and V- terminals. Press scroll key for at least 5 seconds. The display will blink a moment and a new value is obtained. If the display did not blink or the obtained value is equal to -199.9 or 199.9, the calibration failed.

Select the input type as 0 to 20mA in the INPT parameter in bASE menu configuration. Press and hold the scroll key until  $\boxed{\text{RL}}$  appears on the display, then release the scroll key. Press the scroll key for 2-3 seconds then release, the display will show  $\boxed{\text{AdLo}}$  and the unit will enter the calibration mode. Press scroll key to navigate to MA1L. Send a 0mA signal to the mA+ and mA- terminals. Press scroll key for at least 5 seconds. The display will blink a moment and a new value is obtained. If the display did not blink or the obtained value is equal to -199.9 or 199.9, the calibration failed.

Press scroll key and the display will navigate to MA1G. Send a 20mA signal to the mA+ and mA- terminals. Press scroll key for at least 5 seconds. The display will blink a moment and a new value is obtained. If the display did not blink or the obtained value is equal to -199.9 or 199.9, the calibration failed.

### 5.1.1.7 Calibrate Remote Setpoint Input

Select the proper remote setpoint input type in RMSPP and then follow the below procedure to calibrate remote setpoint input.

Select the remote setpoint input type as 0 to 10V in RMSPP parameter in bASE menu parameters. Press and hold the scroll key until  $\boxed{\text{RL}}$  appears on the display, then release the scroll key. Press the scroll key for 2-3 seconds then release, the display will show  $\boxed{\text{AdLo}}$  and the unit will enter the calibration mode. Press scroll key to navigate to V2L. Send a 0V signal to the Remote Set Point V+ and Remote Set Point V- terminals. Please wait for 10 seconds, so the system will have enough input sample to calibrate. After 10 seconds press scroll key for at least 7 seconds. The display will blink a moment and a new value is obtained. If the display did not blink or the obtained value is equal to -199.9 or 199.9, the calibration failed.

Press scroll key and the display will navigate to V2G. Send a 10V signal to the Remote Set Point V+ and Remote Set Point V- terminals. Please wait for 10 seconds, so the system will have enough input sample to calibrate. After 10 seconds press scroll key for at least 5 seconds. The display will blink a moment and a new value is obtained. If the display did not blink or the obtained value is equal to -199.9 or 199.9, the calibration failed.

Select the remote setpoint input type as 0 to 20mA in RMSPP parameter in bASE menu parameters. Press and hold the scroll key until  $\boxed{\text{RL}}$  appears on the display, then release the scroll key. Press the scroll key for 2-3 seconds then release, the display will show  $\boxed{\text{AdLo}}$  and the unit will enter the calibration mode. Press scroll key to navigate to MA2L. Send a 0mA signal to the Remote Set Point mA+ and Remote Set Point mA- terminals. Please wait for 10 seconds, so the system will have enough input sample to calibrate. After 10 seconds press scroll key for at least 5 seconds. The display will blink a moment and a new value is obtained. If the display did not blink or the obtained value is equal to -199.9 or 199.9, the calibration failed.

Press scroll key and the display will show MA2G. Send a 20mA signal to the Remote Set Point mA+ and Remote Set Point mA- terminals. Please wait for 10 seconds, so the system will have enough input sample to calibrate. After 10 seconds press scroll key for at least 5 seconds. The display will blink a moment and a new value is obtained. If the display did not blink or the obtained value is equal

-199.9 or 199.9, the calibration failed.

## 6 Communication

This chapter explains the Modbus Communication protocol of the controller using RS-485 communication. This supports only RTU mode. Data is transmitted as 8-bit binary bytes with 1 start bit, 1 stop bit and optional parity checking (None, Odd, Even). Baud rate may be set to 2400, 4800, 9600, 14400, 19200, 28800, 38400, 57600 and 115200 BPS.

### 6.1 Functions Supported

Only function code 03, 06 and 16 are available for this series of controllers. The message formats for each function code are described as follows.

#### 6.1.1 Function Code 03: Read Holding Registers

Query (From Master)	Slave Address (1~247)	Response (From Slave)	Slave Address (1~247)
	Function Code (03)		Function Code (03)
	Starting Address of Register Hi (00)		Byte Count
	Starting Address of Register Lo (00~79)      Or      Starting Address of Register Lo (128~131)		Data1 Hi
	No of Words Hi (00)		Data1 Lo
	No of Words Lo (1~79)		Data2 Hi
	CRC16 Hi		Data2 Lo
	CRC16 Lo		...
			Data 'n' Hi
			Data 'n' Lo
	CRC16 Hi		
	CRC16 Lo		

**6-1 Function Code 03**



### 6.1.2 Function Code 06: Pre-set Single Register

Query (From Master)	Slave Address (1~247)		Response (From Slave)	Slave Address (1~247)			
	Function Code (06)			Function Code (06)			
	Starting Address of Register Hi (00)			Starting Address of Register Hi (00)			
	Starting Address of Register Lo (00~79)	Or		Starting Address of Register Lo (128~131)	Starting Address of Register Lo (00~79)	Or	Starting Address of Register Lo (128~131)
	Data Hi			Data Hi			
	Data Lo			Data Lo			
	CRC16 Hi			CRC16 Hi			
	CRC16 Lo			CRC16 Lo			

### 6-2 Function Code 06

### 6.1.3 Function Code 16: Pre-set Multiple Register

Query (From Master)	Slave Address (1~247)		Response (From Slave)	Slave Address (1~247)			
	Function Code (16)			Function Code (16)			
	Starting Address of Register Hi (00)			Starting Address of Register Hi (00)			
	Starting Address of Register Lo (00~79)	Or		Starting Address of Register Lo (128~131)	Starting Address of Register Lo (00~79)	Or	Starting Address of Register Lo (128~131)
	No of Words Hi (00)			No of Words Hi (00)			
	No of words Lo (1~79)			No of words Lo (1~79)			
	Bytes Count (2~158)			Bytes Count (2~158)			
	Data1	Hi		Data1	Hi		
	Data1	Lo		Data1	Lo		
	Data2	Hi		Data2	Hi		
	Data2	Lo		Data2	Lo		
	...			...			
	Data	'n'		Hi	Data	'n'	Hi
	Data	'n'		Lo	Data	'n'	Lo
	CRC16	Hi		CRC16	Hi		
CRC16	Lo	CRC16	Lo				

### 6-3 Function Code 16

## 6.2 Exception Responses

If the controller receives a message which contains a corrupted character (parity check error, framing error etc.), or if the CRC16 check fails, the controller ignores the message. However, if the controller receives a syntactically correct message which contains an illegal value, it will send an exception response, consisting of five bytes as follows:

**Slave address +offset function code + exception code + CRC16 Hi +CRC16 Lo**

Where the offset function code is obtained by adding the function code with 128 (i.e. function 3 becomes H'83), and the exception code is equal to the value contained in the following table.

Exception Code	Description	Reason
1	Bad Function Code	The function code is not supported by the controller
2	Illegal Data Addresses	Register address out of range
3	Illegal Data Value	Data value out of range or attempt to write a read-only or protected data

### 6-4 Exception Code

## 6.3 Parameter Mapping

The parameter mapping of Modbus address is available in [section 1.9](#)

## 6.4 Error Code

The description of the Error code is explained below

Error Code	Display Symbol	Description & Reason	Corrective Action
4	ER04	<b>Illegal setup values used:</b> COOL is used for OUT2 when DIRT (cooling action) is used for OUT1, or when PID mode is not used for OUT1 (PB =0 and/or TI=0)	Check and correct setup values of OUT2, PB1, PB2, TI1, TI2 and OUT1. IF OUT2 is needed for cooling control, the controller should use PID mode (PB ≠ 0 and TI ≠ 0) and OUT1 should use reverse mode (heating action), otherwise, OUT2 cannot be used for cooling control
10	ER10	<b>Communication error:</b> bad function code	Correct the communication software to meet the protocol requirements.
11	ER11	<b>Communication error:</b> register address out of range	Do not issue an over-range address of the register to the slave
14	ER14	<b>Communication error:</b> attempt to write a read-only data	Do not write read-only data or protected data to the slave.
15	ER15	<b>Communication error:</b> write a value which is out of range to a register	Do not write an over-range data to the slave register
16	EIER	<b>Event Input Error:</b> Two or more event inputs are set to the same function	Do not set the same function in two or more Event Input Function parameters (E1FN through E6FN)
25	HBER	Holdback time out Error	Check the PV with profile parameters along with PID parameters configuration.
26	ATER	<b>Auto-Tuning Error:</b> Failed to perform Auto-Tuning function	<ol style="list-style-type: none"> <li>1. The PID values obtained after Auto-Tuning process are out of range. Retry Auto-Tuning.</li> <li>2. Do not change the setpoint value during Auto-Tuning process.</li> <li>3. Use manual tuning instead of Auto-Tuning process.</li> <li>4. Do not set a zero value for TI.</li> <li>5. Do not set a zero value for PB.</li> <li>6. Touch RESET key</li> </ol>
29	EEPR	EEPROM can't be written correctly	Return to factory for repair.
30	CJER	Cold junction compensation for Thermocouple malfunction	Return to factory for repair.

Error Code	Display Symbol	Description & Reason	Corrective Action
39	SBER	Input sensor break, or input current below 1 mA if 4-20 mA is used, or input voltage below 0.25V if 1 - 5V is used	Replace the input sensor.
40	ADER	A to D converter or related component(s) malfunction	Return to factory for repair.

### 6-5 Error Code

### 6.5 Mode

The Value of the Mode Register is as below.

Mode Value	Mode
H'000X	Normal mode
H'010X	Calibration mode
H'020X	Auto-Tuning mode
H'030X	Manual control mode
H'040X	Failure mode
H'0X00	Alarm status is off
H'0x01	Alarm status is on

### 6-6 Operation Mode

Bit wise description of Mode register value as below.

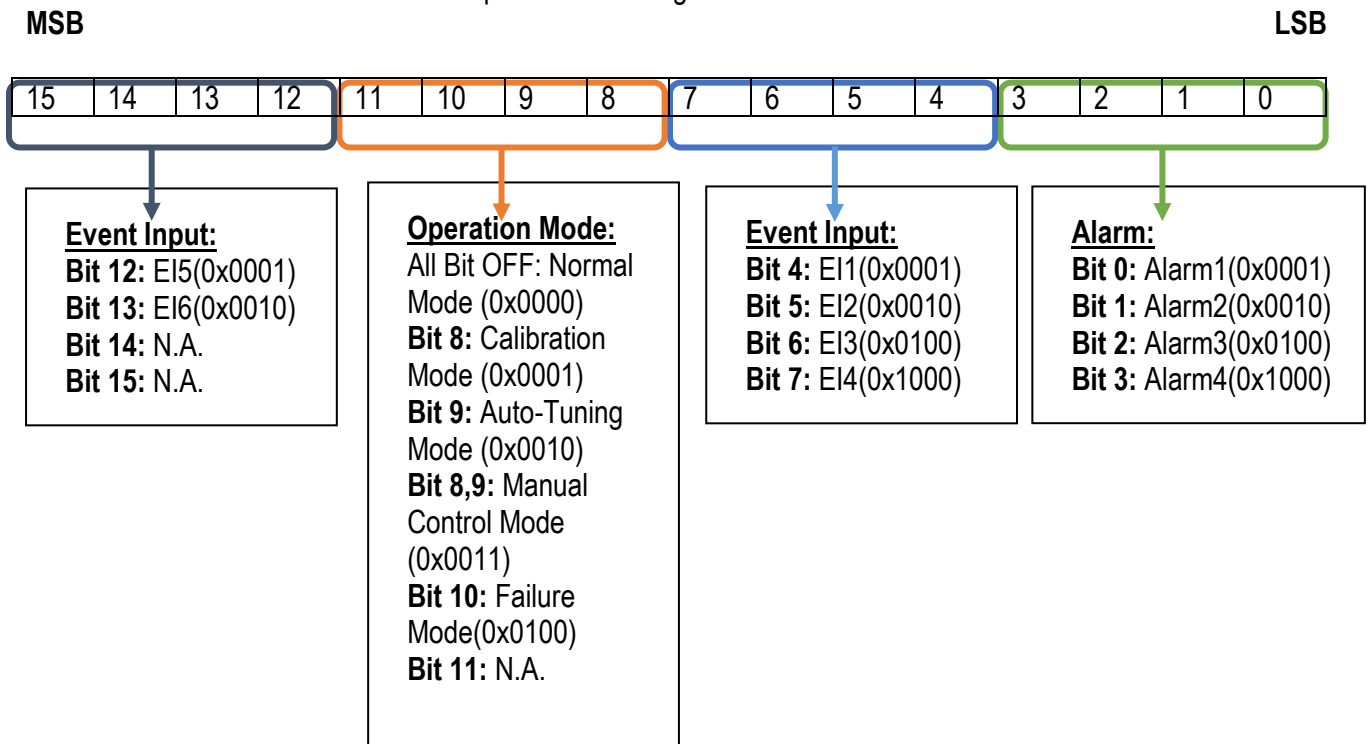

## 6.6 Command Mode

The Value of the Command Mode and job registers are as below.

Command Mode Value		Mode	Description	Job1 Value			Function Code	
Dec	Hex			Dec	Hex	06	16	
26680	6838	Write Date	Set Date Low:0 High:3719 Date=(Y*12+M)*31+D Year=0...9→Y=0...9 Month=1...12→M=0...11 Day=1...31→D=0...30	[DATE]	[DATE]	[DATE]		✓
26665	6829	Calibration Mode	Calibrate ADLO	ADLO	77	004D		✓
			Calibrate ADHI	ADHI	78	004E		✓
			Calibrate RTDL	RTDL	79	004F		✓
			Calibrate RTDH	RTDH	80	0050		✓
			Calibrate CJLO	CJLO	81	0051		✓
			Calibrate CJHI	CJHI	82	0052		✓
			Calibrate V1L	V1L	83	0053		✓
			Calibrate V1G	V1G	84	0054		✓
			Calibrate MA1L	MA1L	85	0055		✓
			Calibrate MA1G	MA1G	86	0056		✓
			Calibrate V2L	V2L	87	0057		✓
			Calibrate V2G	V2G	88	0058		✓
			Calibrate MA2L	MA2L	89	0059		✓
Calibrate MA2G	MA2G	90	005A		✓			
26664	6828	Auto-tuning Mode	Go to auto-tuning mode	...	...	...	✓	✓
26663	6827	Manual Mode	Go to manual mode	...	...	...	✓	✓
26661	6825	Reset	Do same action as Reset Key	...	...	...	✓	✓

## 6-7 Command Mode

When the value of the Command Mode Register is 26663 then the MV1 & MV2 registers can be read and write. Once the command mode register value is 26661 the MV1 & MV2 registers becomes read only.

## 6.7 PROG Code

The Program Code is defined in the below table.

Program Code	Model No
22.XX	C22
62.XX	C62
82.XX	C82
84.XX	C82-Profile
83.XX	C83
85.XX	C83-Profile
72.XX	C72
73.XX	C72-Profile
42.XX	C42
44.XX	C42-Profile
23.XX	R22

## 6-8 Program Code

## 6.8 Scaling

The scale high/low values are defined in the following table for SP1, INLO, INHI, SP1L, SP1H, PV, SV, RELO and REHI

Condition	Scale Low	Scale High
DP=0	-19999	45536
DP=1	-1999.9	4553.6
DP=2	-199.99	455.36
DP=3	-19.999	45.536

### 6-9 Scaling for PV, SV, SP1, INLO, INHI, SP1L, SP1H, RELO, REHI

The scale high/low values are defined in the following table for PB, O1HY, RR, O2HY and ALHY

Condition	Scale Low	Scale High
DP=0	0	65535
DP=1	0.0	6553.5
DP=2	0.00	655.35
DP=3	0.000	65.535

### 6-10 Scaling for PB, O1HY, RR, O2HY, ALHY

## 6.9 Data Conversion

The word data are regarded as unsigned (positive) Integer data in the Modbus message. However, the actual value of the parameter may be a negative value with the decimal point. The high/low scale values for each parameter are used for such conversion.

Let

- M = Value of Modbus message
- A = Actual value of the parameter
- SL = Scale low value of the parameter
- SH = Scale high value of the parameter

The conversion formulas are as follows:

$$M = (65535 \div (SH - SL)) * (A - SL)$$

$$A = ((SH - SL) / 65535) * M + SL$$

If the communication selected with signed integer data in the Modbus message then there is no need of data conversion. The data on the register will be same as actual in the range of -19999 to 32767. When the actual value will exceed 32767 the Modbus register remains at 32767. So, it is not advisable to use signed integer mode of data for the actual data above 32767. This option is available from firmware version 15 in C62, C22 & R22 and firmware version 8 in C42, C72, C82 & C83.

## 6.10 Communication Examples

### 6.10.1 Read PV, SV, MV1 and MV2

Send the following command to the controller via the communication port

	03	00	H'40 H'80	00	04	HI	LO
Slave Address	Function Code	Starting Address	No of Words	CRC16			

### 6.10.2 Perform Reset Function (same effect as pressing R key)

Query

	06	00	H'48	H'68	H'25	HI	LO
Slave Address	Function Code	Register Address	Data Hi /Lo	CRC16			

### 6.10.3 Enter Auto-Tuning Mode

Query

	06	00	H'48	H'68	H'28	HI	LO
Slave Address	Function Code	Register Address		Data Hi /Lo		CRC16	

### 6.10.4 Enter Manual Control Mode

Query

	06	00	H'48	H'68	H'27	HI	LO
Slave Address	Function Code	Register Address		Data Hi /Lo		CRC16	

### 6.10.5 Read All Parameters

Query

	03	00	00	00	H'50	HI	LO
Slave Address	Function Code	Starting Address		No of Words		CRC16	

### 6.10.6 Modify Calibration Co-efficient

Pre-set the CMND register with 26669 before attempting to change the Calibration coefficient

	06	00	H'48	H'68	H'29	HI	LO
Slave Address	Function Code	Register Address		Data Hi /Lo		CRC16	

### 6.10.7 Calibrate ADLO

	H'10	00	H'48	00	02	04	H'68	H'29	00	H'4D	HI	LO
Slave Address	Function Code	Register Address		No of Words		Bytes Count	Data Hi /Lo		Data Hi /Lo		CRC16	



- Please install 20A circuit breaker on the power supply end
- To remove the dust please use the dry cloth
- The installation that the safety of any system incorporating the equipment is the responsibility of the assembler of the system
- If the equipment is used in a manner not specified by the manufacturer, the protection provided by the equipment may be impaired
- Do not cover the cooling vents to maintain airflow
- Beware not to over-tighten the terminal screws. For C22 should not exceed 0.19 N-m (1.74 Lb-in or 2 Kg F-cm) and C62/72/42/82/83 and R22 should not exceed 1 N-m ( 8.9 Lb-in or 10.2 KgF-cm ), temperature Min.60°C, use copper conductors only.
  
- Veuillez installer un disjoncteur 20A à l'extrémité de l'alimentation
- Pour enlever la poussière, veuillez utiliser le chiffon sec
- L'installation que la sécurité de tout système incorporant l'équipement est la responsabilité de l'assembleur du système
- Si l'équipement est utilisé d'une manière non spécifiée par le fabricant, la protection fournie par l'équipement peut être altérée
- Ne couvrez pas les événements de refroidissement pour maintenir le flux d'air
- Attention à ne pas trop serrer les vis des bornes. Pour C22 ne doit pas dépasser 0,19 N-m (1,74 Lb-in ou 2 Kg F-cm) et C62/72/42/82/83 et R22 ne doivent pas dépasser 1 N-m (8,9 Lb-in ou 10,2 KgF-cm), température Min.60°C, utiliser uniquement des conducteurs en cuivre.